



Landscape Standards & Specifications

ACKNOWLEDGEMENTS

In September, 2012, The City of Chestermere's Development and Infrastructure Services committed to a full-scale review of their Landscape Policy and Standards and Specifications documents. A project team was formed to examine the current City document which was based on The City of Calgary 2005. Working with research and information sources from:

- City of Calgary Development Guidelines and Standard Specifications: Landscape Construction 2013
- The Urban Development Institute - Calgary
- The Alberta Association of Landscape Architects
- The Landscape Alberta Nursery Trades Association
- Various Landscape Contractors
- Various new industry/product technologies.

The following documents were produced and approved:

- Landscape Design Guidelines (approved September, 2012)
- Draft Landscape Standards and Specifications produced and forwarded for review and comment to third party agencies (i.e. City of Calgary Parks Department) and local developers/landscape contractors and various landscape product companies (December, 2013)
- Completed Landscape Standards and Specifications (January, 2015)
- Completed updated Landscape Standards and Specifications (June 2020).

PREAMBLE

PRIOR TO THE COMMENCEMENT OF ANY WORK IN THE CITY OF CHESTERMERE, ALL APPROVALS MUST BE IN PLACE. THIS INCLUDES BUT IS NOT LIMITED TO DEVELOPMENT AGREEMENTS AND DEVELOPMENT PERMITS.

The Landscape Standards and Specification provided in this document are considered to be the normal practice for the construction of landscape elements. Their foundation is framed by the following policy documents: The City of Chestermere Design Guidelines, Joint Use Agreement, Master Recreation Plan, Master Drainage Plan, Open Space Policy and Wetland Policy and Plan. The City of Chestermere, at their discretion, may consider alternatives to or relaxations of the Standards and Specifications when the Developer or their agent, or the Contractor or their agent, provides a written submission identifying the reasons for special considerations.

DISCLAIMER

This document is intended to serve as a guideline only. All information provided is subject to addition, deletion, or modification after the date of printing. Although every effort has been made to ensure the accuracy of the contents of this document, no warranty whatsoever is made with respect to the contents. Users of this publication are advised to contact appropriate officials of the City of Chestermere to determine current standards. The City of Chestermere and its employees will not be held liable for any loss or damage incurred by any individual or company as a result of reliance on any of the information contained in this manual.

IMPORTANT NUMBERS

Chestermere Development.....	403.207.7075
Chestermere Community Operations.....	403.207.2807
Utility Safety Partners (formerly Alberta One-Call).....	1.800.242.3447
EPCOR.....	403.207.4503
RCMP.....	403.204.8777
Fire Hall.....	403.272.9878
Community Peace Officers	403.207.8154

EMERGENCY NUMBERS

ATCO Gas.....	1.800.511.3447
Chestermere Infrastructure Services	403.207.2807
EPCOR (Water or Sewer Emergencies)	1.888.775.6677
Fortis Alberta (Electrical Emergencies).....	403.310.9473

TABLE OF CONTENTS

.....	1.0
1 INTRODUCTION	1.11
2 DEVELOPMENT ACTIVITIES	2.13
2.1 Parks	2.13
2.1.1 Development Activities and Responsibilities.....	2.14
2.1.2 Minimum and Maximum Landscape Development Activities.....	2.0
2.2 Boulevards, Medians, and Traffic Islands	2.3
2.2.1 Boulevards and Medians.....	2.3
2.2.2 Traffic Island.....	2.3
2.2.3 Irrigation of Boulevards and Medians	2.3
2.3 Public Utility Lots (PUL) and Right-Of-Ways (ROW's).....	2.4
2.4 Dry Ponds	2.4
2.5 Environmental Reserves	2.4
2.5.1 Glossary of Terms.....	2.4
2.6 Direct Control Sites (DC).....	2.5
General Requirements	2.6
3 General Requirments.....	3.7
3.1 Construction Approval Requirements	3.7
3.1.1 Landscape Development Design Submissions.....	3.8
3.2 Construction Plan Requirements	3.8
3.2.1 General Requirements	3.8
3.2.2 Demolition Plan	3.9
3.2.3 Layout Plan	3.9
3.2.4 Planting Plan	3.9
3.2.5 Natural Environment Park (MR) Restoration Plan for Approved Encroachments	3.10
3.2.6 Grading Plan	3.10
3.2.7 Grid Plan – For MSR Joint Use Sites Only	3.11
	1.3

3.2.8	Irrigation Plan	3.11
3.3	Utility and Pipeline Location Contact Numbers	3.13
3.3.1	Excavation Permits.....	3.13
3.3.2	Field Location & Emergency Service	3.13
3.4	Permission to Use Water for Construction	3.13
3.5	Inspections	3.13
3.6	Construction Completion Certificates (CCC).....	3.14
3.7	Maintenance Period	3.21
3.8	Final Acceptance Certificates.....	3.21
3.8.1	Criteria for Conditional FAC	3.26
3.9	Warranty Period.....	3.26
3.10	CCC and FAC Appeal Process	3.26
4	RECREATION FACILITIES & Amenities	4.28
4.1	RECREATION AND AMENITIES GENERAL design GUIDELINES.....	4.28
4.2	Site Planning Team’s Joint Use Site Guidelines	4.29
4.3	Hockey Rink	4.29
4.4	Soccer Fields and Ball Diamonds	4.29
4.5	Tennis Courts	4.30
4.6	Football Fields/Track & Field Areas	4.32
4.7	Basketball Courts	4.32
5	Trees, Shrubs and general planting.....	5.33
5.1	Development Guidelines	5.33
5.1.1	Design Guideline	5.33
5.1.2	Setback/Spacing Guidelines	5.33
5.1.3	Line Assignment (i.e. setback) requirements	5.34
5.1.4	Boulevard, Medians and Traffic Islands Plantings	5.35
5.1.5	Play Structure Plantings	5.36
5.1.6	Tree Protection Guidelines.....	5.36

5.1.7	Tree Replacement/Compensation Guidelines	5.38
5.1.8	Shrub and Perennial Planting Guidelines	5.38
5.2	Standard Specifications	5.39
5.2.1	Description and Quality Assurance	5.39
5.2.2	Product Delivery, Storage and Handling.....	5.39
5.2.3	Job Conditions/Substitutions.....	5.40
5.2.4	Inspections	5.41
5.2.5	Plant Material	5.41
5.2.6	Mulch.....	5.42
5.2.7	Preparation.....	5.42
5.2.8	Installation	5.43
5.2.9	Maintenance/Pruning/Clean-up	5.43
5.2.10	Transplanting Existing Trees.....	5.44
5.2.11	Pruning.....	5.44
6	SUBGRADE, TOPSOIL, SODDING, and SEEDING	6.45
6.1	Subgrade and Topsoil	6.45
6.1.1	Design Guidelines	6.45
6.1.2	Drainage Guidelines.....	6.45
6.1.3	Description and Quality Assurance	6.46
6.1.4	Submittals.....	6.46
6.1.5	Product Delivery, Storage, and Handling.....	6.46
6.1.6	Job Conditions and Protection	6.46
6.1.7	Inspections and Topsoil Test	6.46
6.1.8	Materials (Detail Sheet COCH-LS #38)	6.47
6.1.9	Subgrade Preparation (Detail Sheet COCH-LS #38)	6.47
6.1.10	Spreading of Topsoil	6.47
6.1.11	Spreading of Topsoil – Natural Areas or Remediation,	6.48
6.2	Sodding	6.48

6.2.1	Description and Quality Assurance	6.48
6.2.2	Product Delivery, Storage, and Handling	6.48
6.2.3	Inspections	6.48
6.2.4	Materials	6.49
6.2.5	Preparation and Installation (Detail Sheet COCH-LS #39)	6.49
6.2.6	Maintenance and Acceptance	6.50
6.3	SEEDING	6.50
6.3.1	Description and Quality Assurance	6.50
6.3.2	Product Delivery, Storage, and Handling	6.50
6.3.3	Inspections	6.50
6.3.4	Materials	6.50
6.3.5	Preparation and Installation.....	6.54
6.3.6	Maintenance and Acceptance	6.55
7	PATHWAYS, TRAILS, and PAVING STONES.....	7.56
7.1	Pathways	7.56
7.1.1	Design Guidelines	7.56
7.1.2	Standard Specifications.....	7.60
7.1.3	Surface Materials.....	7.61
7.2	Trails.....	7.61
7.2.1	Planning Guidelines.....	7.61
7.2.2	Design Guidelines	7.62
7.2.3	Standard Specifications.....	7.62
7.3	Concrete Paving Stones.....	7.63
7.3.1	Description/Quality Assurance	7.64
7.3.2	Materials	7.64
7.3.3	Workmanship and Procedures	7.64
7.3.4	The Base (Detail Sheet COCH-LS #53).....	7.65
7.3.5	Sand Bedding Course (Detail Sheet COCH-LS #53).....	7.65

7.3.6	Installation (Detail Sheet COCH-LS #53).....	7.65
7.3.7	Maintenance.....	7.66
7.4	Permeable Pavers.....	7.66
7.4.1	Description/Quality Assurance	7.66
7.4.2	Materials.....	7.66
7.4.3	Maintenance.....	7.66
8	AMENITIES.....	8.67
8.1	Development Guideline.....	8.67
8.2	Material and Installation Standards.....	8.67
8.3	Play Structures.....	8.67
8.3.1	Design Guidelines	8.67
8.3.2	Description and Quality Assurance	8.68
8.3.3	Inspections	8.68
8.3.4	Materials.....	8.68
8.3.5	Equipment Design and Layout.....	8.68
8.3.6	Installation	8.69
8.3.7	Maintenance.....	8.69
8.4	Site Furnishings and amenities.....	8.69
8.4.1	Description and Quality Assurance	8.69
8.4.2	Inspections	8.70
8.4.3	Design Approval.....	8.70
8.5	Parks signage	8.70
8.5.1	Design, Materials and Installation	8.70
8.6	Fencing.....	8.70
8.6.1	Materials (Chain Link)	8.71
8.6.2	Design	8.71
8.6.3	Installation (Post and Cable) (Detail Sheet COCH-LS 63)	8.71
8.7	Lighting.....	8.71

8.8	Optional Amenities	8.71
8.9	Landscape Boulders and Rocks.....	8.72
8.10	Pedestrian Bridges	8.72
8.11	Retaining Walls.....	8.72
8.12	Maintenance	8.73
9	IRRIGATION	9.74
9.1	Description and Quality Assurance	9.74
9.2	design	9.74
9.3	Product Delivery, Handling, and Storage	9.74
9.4	Job Conditions.....	9.74
9.5	Inspections and Testings.....	9.75
9.5.1	Open Trench Inspections and Testing	9.75
9.5.2	Construction Completion Inspection and Pressure Test.....	9.75
9.5.3	As-Built Drawings (Detail Sheet TOS-LS 64)	9.76
9.5.4	Final Acceptance Certificate Inspections	9.76
9.6	Materials	9.77
9.6.1	Testing.....	9.77
9.6.2	Substitutions	9.77
9.6.3	Piping and Fittings	9.77
9.6.4	Swing Joints and Risers/Sprinkler.....	9.78
9.6.5	Controllers (Detail Sheet COCH-LS #90-91) and Valves (Detail Sheets COCH-LS #66-80) ..	9.79
9.6.6	Wiring requirement Toro Sentinal Central Control Controllers.....	9.81
9.6.7	Electric Valves (Detail Sheets COCH-LS #66-74)	9.82
9.6.8	Gate Valves (Detail Sheet COCH-LS #75)	9.82
9.6.9	Double Check Valve Assembly (Detail Sheets COCH-LS #85-89).....	9.84
9.6.10	Brass Saddles, Tees or Crosses.....	9.84
9.6.11	Irrigation Boxes.....	9.84
9.6.12	Backfill Material	9.86

9.6.13	Sleeving.....	9.86
9.6.14	Miscellaneous Components.....	9.87
9.6.15	Thrust Blocks.....	9.87
9.7	Layout.....	9.87
9.8	Coordination.....	9.87
9.9	Trenching.....	9.87
9.10	Installation.....	9.88
9.11	Backfilling.....	9.89
9.12	Clean Up.....	9.89
9.13	Maintenance.....	9.89
9.13.1	Maintenance of the irrigation system shall include:.....	9.89
10	LANDSCAPE MAINTENANCE.....	10.94
10.1	Preamble.....	10.94
10.2	The City of Chestmere Parks Classifications.....	10.94
10.3	General maintenance.....	10.94
10.4	Mowing.....	10.94
10.5	Garbage Receptacle Emptying & litter control.....	10.95
10.6	Fertilize.....	10.95
10.7	Aerate.....	10.95
10.8	Top Dressing.....	10.95
10.9	Chemical Weed Control.....	10.95
10.10	Tree Well Maintenance.....	10.95
10.11	Shrub Bed Maintenance.....	10.96
10.12	Irrigation Maintenance.....	10.96
10.13	snow and ice management.....	10.96
10.14	Building and Janitorial Maintenance.....	10.96
10.15	Playground Inspection and Maintenance.....	10.96
10.16	Tree Pruning.....	10.97

10.17	Water Features (Ponds and Lagoons)	10.97
10.18	Fence Maintenance	10.97
10.19	Playfields and courts	10.97
11	DETAIL SHEETS.....	11.99

LIST OF TABLES

Table 1 - Municipal Government Acts & Other Provincial & Federal Legislation	1.11
Table 2 – Municipal Reserve Dedication.....	2.16
Form 3 – FAC Field Inspection Report	3.39
Form 4 – FAC Application	3.41
Form 5 – Parks Irrigation Meter Sheet.....	9.104
Form 6 – Irrigation Information Sheet	9.110

1 INTRODUCTION

The purpose of The City of Chestermere Landscape Guidelines and Landscape Standards and Specifications is to provide:

- A list of appropriate development activities for each park Class;
- Concept planning requirements at the Land Use/Outline Plan stage;
- Construction approval requirements;
- Requirements for inspections during construction;
- Construction Completion Certificate requirements;
- Final Acceptance Certificate requirements; and
- Detail specifications for landscape construction.

Concept plans and construction plans shall reflect the policies and conditions approved at the Community Planning and Land Use / Outline Planning stages. Community Plans and Land Use / Outline Plans shall conform to Council approved policies and Federal/Provincial legislation. The following table illustrates these relationships:

Table 1 - Municipal Government Acts & Other Provincial & Federal Legislation

City-wide / larger in scope; multiple functions; partnerships	City of Chestermere Plans and other Council – approved policies (i.e., Municipal Development Plan (MDP); Design Guideline)		Joint Use Agreement
City-wide; all open space	Landscape Guidelines Engineering Specifications		Master Recreation Plan (MRP) Chestermere Design Guidelines
City-wide; specific to an issue or aspect of open space. Examples include:	Wetland Policy & Plan Open Space Policy	Master Drainage Plan Master Transportation Plan	Tree Protection Plan
Policy for a broad geographic area	Master Area Structure Plans (MASP)		Area Structure Plans (ASP)
Plans for location / configuration of open space in a specific area (implementation)	Land Use Amendments	Outline Plans	Tentative (Subdivision) Plans
Implementation of policy through development of a specific site or project	Development Permits Development Agreements		Design Development Plans for City Capital Park projects



Development Activities

2 DEVELOPMENT ACTIVITIES

2.1 PARKS

The City of Chestermere's Parks and Recreation Open Space Maintenance Standards states the overall Parks and Recreation Goals are:

- Promote Active Transportation and Connectivity . Establish a continuous multi-use pathway system that promotes and supports active transportation - connecting neighborhoods to community facilities, places of work and shopping areas.
- Facilitate a Sense of Community and Diversify the Social Infrastructure. Create a well-planned network of parks, pathways and recreation spaces that promotes a sense of community, where people can play, be active and gather for social activities.
- Preserve our Natural Landscape, Culture and Heritage. Optimize and complement our natural landscape, culture and heritage. Ensure that the development and management of our parks, beaches, green spaces, pathways and recreation amenities are environmentally responsible.
- Partnerships and Linkages. Partner with our neighboring municipalities to leverage regional pathway connectivity and complement regional park amenities. Partner with developers to optimize the development of pathways and outdoor recreation amenities; and support economic development and tourism.
- Promote Active Living and Fun. Ensure that residents have access to a broad range of fun recreation, leisure and sport opportunities so that they remain healthy. Facilitate a variety of regional and local facilities that are multi-purpose, flexible and adaptable. Ensure further study of Chestermere Lake to determine the appropriate water usage, safety, best public access practices, and the impact of future population growth on lake use.

2.1.1 DEVELOPMENT ACTIVITIES AND RESPONSIBILITIES

Parks development process and requirements:

(Please note: this is landscaping specific, see The City of Chestermere's planning process for the entire subdivision development requirements.)

Area Structure Plans (ASP)

- Regional pathway connectivity
- Proposed open space areas
- ER or noted significant ecological features
- Recreation intent encouraged

Outline Plans (OP)

- Regional and local pathway systems
- Approved concept landscape plans for MR, MSR, ER, PUL
- Recreational intent shown in conceptual plans
- ER or noted significant ecological features (if not completed in MASP or ASP)
- Confirmation of MR dedication
- Note any optional amenities

Development Agreement (DA)

- Approved concept landscape plans for MR, MSR, ER and PUL (if not previously approved in OP)
- ER or noted significant ecological features (if not previously approved in OP)
- Optional amenities agreement completed as a clause in the DA

Landscape Construction Commencement

- Approved technical landscape drawings for the phase or parcel
- Call Parks Department for the initial inspection

Construction Completion Certificate (CCC)

- Completed field inspections and received approval from the Parks Department
- Minimum one year maintenance and establishment period after CCC
- Optional amenities payment due prior to FAC application

Final Acceptance Certificate (FAC)

- Completed field inspections and received approval from Parks Department.

DEFINITIONS OF PARK TYPES

Sub neighbourhood parks

Municipal Reserves (MR), i.e. Tot lots, decorative parks or ornamental parks that are +/- 0.2 hectares (+/- 0.5 acres). These parks are part of the 10% reserve dedication.

Neighbourhood parks

Municipal Reserves (MR), i.e. Tot lots, decorative parks or ornamental parks that are 0.4 to 3.6 hectares (1.0 to 8.9 acres). These parks are part of the 10% reserve dedication.

Community parks

MR and/or Municipal School Reserves (MSR), i.e. Tot lots, school grounds, recreation grounds or community lease sites that are 3.6 to 9.2 hectares (8.9 to 23 acres). These parks are part of the 10% reserve dedication. The following types of school sites, with or without a community lease site, are defined as community parks:

- Public Elementary School (4 ha. / 10 acres)
- Public Junior High School (4.9 ha. / 12 acres)
- Public Elementary and Junior High Schools (6.9 ha. / 17 acres)
- Separate Elementary School (3.6 ha. / 9 acres)
- Separate Elementary and Junior High school (4.9 ha. / 12 acres)

District Parks or Regional Parks

MR i.e. Tot lots, regional parks, destination parks, beaches, recreation grounds, major event parks, these parks are part of the 10%

MSR, i.e. School grounds, recreation grounds or community lease sites that are greater than or equal to 9.2 hectares (23 acres). These parks are not part of the 10% reserve dedication.

The following type of school site, with or without a community lease site, is defined as a district park:

- Public/Separate High School (9.2 ha. / 23 acres)

Linear Parks

MR that has a minimum width of 10 m and a maximum width of 20 m, and that accommodates a regional pathway or performs a linear recreation function by providing local or regional pathway links to educational, recreational, and open space features (e.g. natural environment parks) within and between communities. These parks can be part of the 10% reserve dedication with considerations to the amount of over all acreage dedicated to programmable recreation.

Environmental Reserve (ER)

An area preserved for its natural habitat. See the Municipal Government Amendment Act, 2000; Chapter M-26; Part 17; Division 8, Section 664).

These will **NOT** be considered for part of the 10% reserve dedication. Environmentally Significant Areas (ESA's) will be treated as ERs.

Public Utility Lots (PUL)

Public Utility Lots are not included in the reserve dedication as the utilities may render the lands undevelopable to required amenities and plantings.

Table 2 – Municipal Reserve Dedication

10% Reserve Dedication			
Land Use	Qualify %	Description	Parcel Size
MR	100%	Sub neighbourhood, neighbourhood	.5 acres - 22 acres
		Tot lots, decorative parks or ornamental parks	
MR / MSR	100%	Community Parks	
		Tot lots, school grounds, recreational grounds, community lease sites.	.5 - 22 acres
		Public Elementary School	10-17 acres
		Public Junior High School	12- 17 acres
		Separate Elementary School	9 acres
		Separate Junior High School	12 acres
MR	100%	District Parks	23 acres +
		Tot lots, decorative parks or ornamental parks or public amenities	
MSR	0%	District Parks	23 acres +
		Public / Separate High School, recreation grounds, or community lease sites	
Lineal MR	100%	Park that provides regional or local connectivity and the community provides other functional and programable space.	10m - 20m wide
Lineal MR	0%	Park that provides regional or local connectivity	> 10m or < 20m wide
PUL	0%	Public Utility Lots --	any size
ER	0%	Environmental Reserve - MGA 664	any size
Boulevards	0%	Boulevard, medians and traffic circles	any size
Storm Ponds	50%	Above the 1:100 year flood level could be considered for 50% credit provided that the proposed MR area is easily accessible and meets recreational priorities.	Miniumum 10m or wider from NWL to property line.

Table 3 illustrates responsibility for park development activities for parks and open space. The intent of the table is to provide the reader with a summary of the various types of parks and their appropriate level of development.

Table 3 - Responsibility for Park Development Activities

* Appropriate Development Activities	Sub-Neighbourhood Parks (MR)	Neighbourhood Parks (MR)	Community Parks MR MSR		District Parks MR MRS		Linear Parks
Grade	D	D	D	D	D	D	D
Loam	D	D	D	D	D	D	D
Seed to Grass	D	D	D	D	D	D	D
Fully-Automatic Irrigation (50 mm PWS)	NR	NR	NR	NR	NR	NR	NR
Fully-Automatic Irrigation (150 mm PWS)	NR	NR	NR	NR	NR	NR	NR
1.2 m Chain Link Fence (private property)	D	D	D	D	D	D	D
Post and Cable Fence	NR	NR	NR	D	NR	D	NR
Optional Amenities	D	D	D	D	D	D	D
Regional and local Pathway	D	D	D	D	D	D	D
Trees	D	D	D	D	D	D	D
Perennials	N/A	N/A	D	N/A	D	N/A	N/A
Shrubs	D	D	D	D	D	D	D
Benches	D	D	D	D	D	D	D
Garbage Receptacles	D	D	D	D	D	D	D
Supply Signs	C	C	C	C	C	C	C
Install Signs	D	D	D	D	D	D	D
Play Equipment	D	D	D	NR	D	D	NR
Exercise Equipment	NR	NR	NR	NR	NR	NR	NR
Game Amenities	D	D	D	NR	D	NR	D
Accessible Picnic Tables	D	D	D	D	D		NR
Basketball / Hockey Multicourt	N/A	D	D	NR	D	NR	N/A
Volleyball	D	D	D	D	D	D	N/A
Ball Diamond	N/A	D	D	D	D	D	N/A
Soccer Field	N/A	D	D	D	D	D	N/A
Football Field/ Rugby	N/A	N/A	N/A	D	D	D	N/A
Tennis / Pickleball Courts	N/A	NR	D	D	D	D	N/A
Bleachers	N/A	N/A	D	D	D	D	N/A
Portable Washrooms	C	C	C	C	C	C	N/A
Parking	NR	NR	D	D	D	D	N/A
Flat Open Space (Snow Bank Rink)	D	D	D	D	D	D	D
400 m Track	N/A	N/A	N/A	NR	NR	NR	N/A
Lighting	NR	NR	NR	NR	NR	NR	NR

* Current Development Responsibility

D Developer is responsible for appropriate development activity.

C City/Community is responsible for appropriate development activity.

N/A Development activity is not appropriate.

NR Development activity not required, however, the Developer or Community Association may apply for its implementation.

2.1.2 MINIMUM AND MAXIMUM LANDSCAPE DEVELOPMENT ACTIVITIES

A Developer is responsible to construct in accordance with the minimum and maximum landscape development standards indicated in Tables 2 to 6 and to the satisfaction of The City of Chestermere Parks Department for all local parks. Local parks are defined to be sub-neighbourhood parks, neighbourhood parks, community parks, and district parks.

Table 4 Sub-Neighbourhood Parks – MR 0-1 acres

<i>Item</i>	<i>Quantity</i>		<i>Type/Comment</i>
	<i>Minimum</i>	<i>Maximum</i>	
Grading/Loaming	Entire Site	Entire Site	As per specifications
Turf	Entire Site	Entire Site	As per specifications
Trees	20 trees/acre	40 trees/acre	As per specifications
Irrigation	Based on site requirements	Entire Site	As per specifications
Benches	1 Per Site	5 Per Site	Minimum
Parks Sign	1 Per Entrance	1 Per Entrance	As per specifications
Pathways	As Required	2.5 m wide	As per specifications
Fencing	As Required	Traffic control or barrier	Post and cable or post on post
Play equipment or other recreation equipment	1 per site	If Suited	To community needs or preference if desired
Sport Fields / Parking	Depends on size	Depends on size	To community needs or preference if desired.
Games Tables	1 Per Site	As suited	To community needs or preference if desired.
Picnic Tables	1 Per Site	As suited	Minimum 1 accessible table
Off leash /Parking	If Suitable	If Suitable	To community needs or preference if desired
Retaining Walls	As required	As required	As per specifications
Garbage Receptacles	1 Per Entrance	1 Per Entrance	Near walkways; not benches
Shrubs	0m ² /acre	50 m ² /acre	Based on tree count.
Perennials	0 Per Site	20 m ² /acre	At significant features only

Table 5 - Neighbourhood Parks – MR 1.0 to 8.9 acres

Item	Quantity		Type/Comment
	Minimum	Maximum	
Grading/Loaming	Entire Site	Entire Site	As per specifications
Turf	Entire Site	Entire Site	As per specifications
Trees	15 trees/ acre	30 trees/ acre	As per specifications
Irrigation	Based on site requirements	Entire Site	As per specifications
Benches	2 Per Site	5 Per Site	
Parks Sign	1 Per Entrance	1 Per Entrance	As per specifications
Pathways	2.5m wide	3 m wide	Regional or Local
Fencing	As Required	Traffic control or barrier	Post and cable or post on post
Play equipment or other recreation equipment	If Suited	2 Per Site	To community needs or preference if desired
Washrooms	As Required	As Required	
Sport Fields / Parking	Softball or Soccer, as appropriate	1 – 76 m softball 1 – Major Soccer (minor overlap)	15 parking stalls/diamond 20 parking stalls/soccer fields
Games Tables	1 Per Site	3 Per Site	To community needs or preference if desired
Picnic Tables	1 Per Site	10 Per Site	To community needs or preference if desired
Basketball/Volleyball	1 Per Site	1 Per Site	If room allows
Garbage Receptacles	1 Per Entrance	1 Per Entrance & picnic areas	Near Walkway not benches
Shrubs	0	50 m ² /acre	Based on tree count.
Perennials	0 Per Site	20 m ² /acre	At significant features only
Off leash /Parking	If Suitable	If Suitable	To community needs or preference if desired
Retaining Walls	As Required	As Required	1 m height with mowing strip when abutting turf areas

Table 6 - Community Parks - MSR and MR 8.9 to 23 acres

Item	Quantity		Type/Comment
	Minimum	Maximum	
Grading/Loaming	Entire Site	Entire Site	As per specifications
Turf	Entire Site	Entire Site	As per specifications
Trees	10 trees/0.405 ha (1 ac)	15 trees/0.405 ha (1 ac)	As per specifications
Irrigation	Based on site requirements	Based on site requirements	As per specifications
Parks Sign	1 per Entrance	1 per Entrance and areas as required	As per specifications
Pathway	2.5m local pathway	Regional Pathway 3 m wide	As per specifications
Fencing	As Required	As Required	Post and cable or post on post or chain link. Or on case by case basis.
Play Equipment or Other Recreation Equipment	1 Per Site	1 Per Site	To community needs or preference if desired
Ball Diamonds/Parking	1 Per Site	No Maximum	15 parking stalls /76 m softball As Per Spec
Benches	2/Ball Diamond, Court or Field	2/Ball Diamond, Court or Field	Players Benches
Washrooms	Not required	2/Ball Diamond, Court or Field	As per specifications
Bleachers	1/ Ball Diamond, Court or Field	2/Ball Diamond, Court or Field	As per specifications
Soccer Fields/Parking	1 Per Site	No Maximum	20 parking stalls / major/minor soccer As Per Spec
Football Field	1 Per Site	No Maximum	As per specifications
Ice Rink	1 Per Site	No Maximum	As per specifications
Tennis Courts	1 Per Site	No Maximum	As per specifications
Field Event Area	1 Per Site	No Maximum	As per specifications
Garbage Receptacles	1 Per Entrance	1 Per Entry or as needed.	Near Walkway
Off leash /Parking	If Suitable	If Suitable	To community needs or preference if desired
Shrubs	50 m ² /ha	70 m ² /ha	As per specifications
Perennials	0 Per Site	20 m ² /acre	At significant features only
Retaining Walls	As Required	As Required	1.5 m height with mowing strip when abutting turf area

2.2 BOULEVARDS, MEDIANS, AND TRAFFIC ISLANDS

2.2.1 BOULEVARDS AND MEDIANS

Grade, loam and seed or sod to grass. All trees planted in a boulevard must be approved by The City of Chestermere Parks Department,

2.2.2 TRAFFIC ISLAND

If less than 500 m² in area:

- a. Hard surface low maintenance material as approved by The City of Chestermere Parks Department.

If greater than 500 m² in area:

- a. Grade, loam and seed or sod to grass;
- b. 50 mm P.W.S. and automatic pop-up irrigation system;

All trees planted in a traffic island must be approved by The City of Chestermere Parks Department.

All traffic islands will have a 1 m concrete maintenance strip installed directly behind the curb.

Boulders, signs and other obstacles must be:

- a. At least 1 m back from the curb;
- b. A minimum of 4.5 m from the bullnose or back of walk extended through the island, whichever is greater, adjacent to the primary streets;
- c. A minimum of 4.5 m from 'any' bullnose adjacent to primary streets on irregular shaped islands; and
- d. A minimum of 3.0 m from the bullnose inside the cul-de-sac.

The minimum width of traffic islands containing coniferous trees shall be 7.0 m.

2.2.3 IRRIGATION OF BOULEVARDS AND MEDIANS

The following is The City of Chestermere's criteria for storm pond irrigation systems proposed within boulevards and medians. Note that irrigating boulevards and medians is a non-standard practice; one **not** encouraged by The City of Chestermere for safety and water conservation reasons. No potable water irrigation systems will be approved on medians or boulevards.

- a. If a Developer or homeowners'/residents/community association wishes to irrigate boulevards or medians within a community, they must receive approval from The City of Chestermere Development and Infrastructure Services and enter into a Landscape Maintenance Agreement with The City.

NOTE: *The intent to enter into a Landscape Maintenance Agreement must be identified at the Outline Plan Stage via a letter of intent or other suitable mechanism.*

- b. Design and construction of irrigation systems within boulevards and medians shall be in accordance with the current issues of The City's Guidelines, Landscape Standards and Specifications, Engineering Standards, and the Land Use Plan.
- c. Sleeving shall be either C900 PVC (bell and spigot) pipe bedded as per backfill material specification (Pg. 156, 6.12a and 6.12b), installed below the bed for a pathway, sidewalk, driveways or PVC SDR 35 (bell and spigot).

NOTE: *Sleeving to be bedded in accordance to [The City of Calgary Standard Specifications for Sewer Construction](#).*

- d. An Optional Amenity Agreement, in an amount determined by The City of Chestermere Development and Infrastructure Services and Parks, shall be provided.

2.3 PUBLIC UTILITY LOTS (PUL) AND RIGHT-OF-WAYS (ROW'S)

Grade, loam and seed or sod to grass; chain link, wood screen or other type of fencing as approved by The City's Parks Department on the flankage and rear of lots that abut ROW; post and cable barrier, installed in the asphalt, where PUL or ROW abuts lane.

2.4 DRY PONDS

Dry ponds are no longer supported by the City of Chestermere.

2.5 ENVIRONMENTAL RESERVES

Environmental Reserves (ER) will be undisturbed unless approved by City of Chestermere Parks Department. During construction of the adjacent lots, construction fence or equivalent will be present to preserve the area in its natural state.

2.5.1 GLOSSARY OF TERMS

Environmental Reserve	See the Municipal Government Amendment Act, 2000; Chapter M-26; Part 17; Division 8, Section 664).
Municipal Reserve	See the Municipal Government Amendment Act, 2000; Chapter M-26; Part 17; Division 8, Section 666.
Environmentally Significant Area	A natural area site that has been inventoried prior to potential development and which because of its features or characteristics is significant from an environmental perspective to Chestermere and has the potential to remain viable in an urban environment. A site is listed as an Environmentally Significant
Preservation Zone	Implies intent to maintain a natural environment in its present condition.
Restoration Zone	Implies intent to improve an area to near its natural and native condition. Such an area plays a role in the nearby natural system or vegetation community.
Disturbed Zone	An ER or Natural Environment Park (MR) that is not substantially in its natural and native condition, and is cut off from the nearby natural system or vegetation community.
Native	Species of animal or plant that have not been introduced by people or their direct activity.

Near Native Condition	A vegetation community is not dominated by introduced species or seriously affected by damage.
Sensitivity	Measures the amount of un-immitigable damage that a particular vegetation community or species can withstand.
Resource Significance	Refers to the level of importance of the area in question to a future park area.
Vegetation Community	A group of populations of plants in a given area.
Historic/Archaeological	Refers to written/prewritten evidence/artifacts.
Natural System	A group of areas that are ecologically dependent.
Development Encroachment	A non-legal or non-judgmental term which refers to development activities in an ER.
Utility Encroachment	Implies a non-legal or non-judgmental term which refers to utility development (i.e. natural gas, sewer, electrical, etc.) in an ER.
Park Amenity	A park development project, such as pathway, trail, bench, or viewing platform.
Non-Native	Any introduced species of animal or plant.
Restoration	The efforts to restore a site to near native condition.
Reclamation	The efforts to improve a disturbed site's condition.
Naturalization	The process of leaving a disturbed site to natural processes.
Rehabilitation	The above three terms – i.e. the efforts to restore a site to near native condition, or the efforts to improve a disturbed site's condition, or the process of leaving a disturbed site to natural processes.

2.6 DIRECT CONTROL SITES (DC)

As DC sites are not property under the ownership of The City of Chestermere they should not share an irrigation water service with a park property. The City of Chestermere Parks Department will not inspect CCC or FAC on DC sites as they are private property. Contact Planning.



General Requirements

3 GENERAL REQUIREMENTS

3.1 CONSTRUCTION APPROVAL REQUIREMENTS

Prior to commencing any landscaping on any subdivision, park or public land within the City boundaries, the contractor may confirm the appropriate approval process with the Parks Department.

The following requirements generally apply to the various forms of development as undertaken:

Table 7 - Construction Approval Requirements for Various Forms of Development

<i>Construction Type</i>	<i>Requirements for Approval</i>	<i>Time for Review and Comments</i>
Utility and Roadwork	Contractor form through Parks	10 working days
Tree Protection Plan	Tree Protection Plan forms completed electronically submitted to the Parks Department including landscape plans (pdf format)	10 working days
Open Space & Lake Access Agreement (for construction or access to construction on City owned land)	Open Space Access Agreement completed electronically submitted to Parks Department including landscape plans (pdf format)	10 working days
Landscape Construction (Grading, loaming, seeding, irrigation, planting, hard surface treatments, play structures, site structures, etc.)	Digital construction files (pdf format) to Parks Department for new subdivisions.	15 working days
Landscape Construction on roadways, public utility lots and easements	a) Digital construction files (pdf format) to Parks Department for new subdivisions.	15 working days
	b) Digital construction files (pdf format) to Parks Department for non-standard tree planting proposals in existing areas, or where utility lines are involved.	

Note: Time for Review and Comment is assuming all submissions are complete.

3.1.1 LANDSCAPE DEVELOPMENT DESIGN SUBMISSIONS.

The Parks Department will copy the Developer on all correspondence resulting from landscape construction drawing submissions. To facilitate this, all submissions for the approval by Parks Department of landscape construction drawings shall include the Developer's name, company and address, and the appropriate contact information for the Developer's Project Manager or consultant.

Landscape components submitted for design acceptance should be submitted in specific groupings by development phase to reduce the frequency of inspections and the volume of documentation by The City of Chestermere Parks Department and the Developer. Recommended groupings are:

- | | |
|---|----------------------------------|
| i. All reserve parcels; | iv. All storm ponds; and |
| ii. All boulevards, medians, and traffic islands; | v. All Public Utility Lots (PUL) |
| iii. All Environmental Reserves; | |

- a. **NOTE:** Where the PUL is dedicated for the purpose of a shallow utility cabinet or pedestal only, and embedded in a Municipal Reserve, the PUL may be included in the FAC application for the Municipal Reserve.

CCC and FAC inspections will be based on design submittal packages. i.e. If a line assignment and traffic circle are submitted as one design, that entire submission must be completed prior to final CCC application. All construction plans should show the development agreement phase boundary on the key plans. This will be used by the landscape reviewer to ensure that all components within the phase are complete as per the specific groupings identified in Construction Completion Certificate (CCC).

For landscape development submissions: submit via email, digital construction files (pdf format) for review and comments. Correspondence will remain electronic until notice of approval is given to the sender via email. For official and final acceptance, the filing of one ,11 x 17, hard copy (no mylar) will be required by the Parks Department. The remaining drawing sets received will be stamped and returned to the consultant for their records. At CCC, as-built digital files (dwg and pdf formats) must be submitted.

3.2 CONSTRUCTION PLAN REQUIREMENTS

The following information will be provided with any drawings submitted to The City of Chestermere Parks Department for construction approval. Landscape construction drawings are to be submitted only by Registered Landscape Architects.

3.2.1 GENERAL REQUIREMENTS

- a. All landscape construction plans shall be sealed and signed by a Registered Landscape Architect with current membership in the Alberta Association of Landscape Architects
- b. All drawings and supplemental material(s) for irrigation systems that will be turned over to The City, shall be stamped and signed by a Certified Irrigation Designer (CID) – Commercial. The certification must be issued by the Irrigation Association, Calgary, AB. The certified designer must be in good standing with the association.
- c. Scale in metric (preferred scales: 1:200, 1:250, 1:500).
- d. North arrow.
- e. Key plan oriented in same direction as site plan.
- f. Legal description and zoning of site and property lines including bearings and dimensions. If the site has a municipal address, include it in the plan.

- g. Land uses of surrounding parcels and grades at property line. (i.e. residential, commercial, industrial, etc.).
- h. Utility locations and legal easements, Right-of-Ways, etc.
- i. Curb lines, sidewalk, utility poles, fences and any other boundary condition.

The following information shall apply to specific plans in conjunction with the information noted above.

3.2.2 DEMOLITION PLAN

- a. Labeled as "Demolition."
- b. Existing above & below grade features to be protected & to be removed.
- c. Existing vegetation.
- d. Existing irrigation.

3.2.3 LAYOUT PLAN

- a. Labeled as "Layout."
- b. Existing features to be saved.
- c. Location of proposed structures and features.
- d. Layout of playground as per CSA guidelines, including non-encroachment zones.
- e. Location of all signs.
- f. Layout of planting beds in relation to amenities.
- g. Identify and label the following park areas:

i. Preservation Zones

Preservation areas are portions of parks, which are to remain in their natural condition. The layout plan should identify the significance of the preservation areas, such as their habitat types and the grouping of vegetative communities that may support their ecological systems. The plan should also indicate how controlled human use is to be accommodated within the preservation areas.

ii. Naturalized Zones

Naturalized areas are portions of parks, which are proposed for reclamation to as natural a state as possible. They include manicured areas and/or disturbed or partially disturbed natural areas. Vegetative cover shall include native grasses and/or trees and shrubs that may support the ecological system. Once established, maintenance is to be limited to fire and weed control as well as garbage removal. The plan should also indicate how controlled human use is to be accommodated within the naturalized area.

iii. Manicured Zones

Manicured areas are portions of parks that have defined 'special use areas'. They imply some development as identified in the minimum standards and maintenance that is relatively intense compared to preservation and naturalized areas. Manicured areas include areas where larger numbers of park users are anticipated; i.e. sports fields, playgrounds, community uses.

3.2.4 PLANTING PLAN

- a. Labeled as "Planting."
- b. Show major items associated with "Layout" but not including dimensions, i.e. walkways, roads, curbs, hard surface areas, fountains, other structures, natural areas.
- c. Show material with canopy at two-thirds (2/3) maximum size.

- d. Outline of planting beds and tree wells.
- e. Proposed contours at 0.5 m intervals.
- f. Utilities / ROWs.
- g. Plant list identifying species (botanical and common name), quantities, sizes, habitat, spacing and specific remarks as required.
- h. Provide m² of all beds
- i. Provide mulch or bed surface details.
- j. Details as required but which are not included in standard specifications.

3.2.5 NATURAL ENVIRONMENT PARK (MR) RESTORATION PLAN FOR APPROVED ENCROACHMENTS

- a. Labeled as "Restoration Plan."
- b. Pre-development biophysical inventory of the site. At a minimum, the inventory will include:
 - i. An inventory of plant species composition and an assessment of relative abundance.
 - ii. Soils described using the Canadian system of Soil Classification – classified to Soil Group. Provide texture and horizon depths.
 - iii. Site description sufficient to establish the ecological characteristics of the site including:
 - Exposure (i.e. south facing, dry and exposed);
 - Slope position (i.e. mid-slope, slope crest, level);
 - Topography (i.e. rolling with micro-topographic variation of approximately 5.0 m – hummocky); and
 - Sufficient detail must be provided so that the current condition of the site can be assessed and used to determine the desired objectives of the restoration.
 - iv. Include site preparation methods, i.e. a season of weed control prior to reseeding.
 - v. Include seed mix(es) and application rate(s) specific to the site conditions.
 - vi. Include seeding method (hydroseeding, Brillion, etc.)
 - vii. Plant material shown with crowns at two-thirds (2/3) maximum size as noted in "Alberta yards & Gardens: What to Grow" or "Alberta Horticultural Guide."
 - viii. Proposed contours at 0.5 m intervals.
 - ix. Utilities / ROWs
 - x. Planting list identifying species (botanical and common name), quantities, sizes, habit, spacing densities and specific remarks as required.

NOTE: *Plant cultivars are only acceptable if approved by Parks Department; and the spacing and densities of plantings are to replicate the biophysical inventory.*
 - xi. An achievable set of criteria that constitutes a successful restoration of the site to be prepared in consultation with the Developer.
 - xii. Depth of predevelopment topsoil and location of proposed stockpile.
 - xiii. Proposed maintenance schedule.

3.2.6 GRADING PLAN

- a. Labeled as "Grading."
- b. Major items associated with layout but not including dimensions, i.e. walkways, play fields, roads, curbs, other structures, and natural areas.

- c. Existing and proposed contours at 0.5 m contour intervals.
- d. All grades shall be Geodetic measure and tied to the nearest A.S.C.M. benchmark; A.S.C.M. benchmark number to be indicated on plan.
- e. Elevations to be shown at each break point (top and toe of slope).
- f. Label property lines and show spot elevations.
- g. Catch basin rim and invert elevations where required.
- h. Manhole rim elevations.
- i. Top of wall, top of curb, finished floor elevations as required.
- j. Surrounding grade information affecting site development.
- k. Label all concrete gutters.

NOTE: *Where possible, concrete gutters are to be located on private property.*

- l. Show all trap lows showing their 1:100 inundation area and emergency spill routes.
- m. Show grading percentage and directional arrows where grades are less than 2.5%, or greater than 7% on hard surface and 20% on softscape areas.
- n. If site grades are different from the approved grading plan or there appears to be a drainage, safety or layout concern as identified by the Parks Department, as-built grading plans on an acceptable grid and tied to legal boundaries are to be provided by the developer and approved by The City of Chestermere Parks Department prior to the signing of the CCC.

3.2.7 GRID PLAN – FOR MSR JOINT USE SITES ONLY

- a. Labeled as “Grid.”
- b. Existing and proposed spot elevations on a 15 m grid and tied to legal boundaries are required.
- c. All grades shall be Geodetic measure and tied to the nearest A.S.C.M. benchmark; A.S.C.M. benchmark number to be indicated on plan.
- d. Label property lines.
- e. Catch basin rim and invert elevations where required.
- f. Surrounding grade information affecting site development.
- g. School building envelope to have same grade as sports field envelope (i.e. 2%).
- h. School building envelopes and adjacent road grades must be at the same elevation.
- i. For every 1.0 m in elevation in excess of 2% slope, a minimum increase of 3.0 m will be required on site.
- j. Refer to Chapter 4 Recreation Facilities for all sports field design and grading specifications.

3.2.8 IRRIGATION PLAN

- a. Labeled as "Irrigation."
- b. Major items associated with "Layout" but not including dimensions, i.e. walkways, structures, fences, play fields, roads, curbs, and natural areas.
- c. Screened back major items of “Planting” and “Grading” plans.
- d. Proposed contours at 0.5 m intervals.
- e. Irrigation systems must be contained in one parcel submission and will not be phased. For proposed larger phased parcels the irrigation system must either contain a new controller in each phase or continued maintenance of entire parcel will be required until FAC of the entire irrigation system.
- f. Locations of all lines, sprinkler heads, valves, drains, sleeves, electrical drop-offs, 100-volt wire, 110-volt conduit, electrical controllers, dimensional from adjacent property lines.

NOTE: The irrigation system as shown on the plan is approximate and shall be adjusted to suit site conditions

- g. Design the irrigation system so that sprinkler heads do not spray into playgrounds or major amenities.
- h. Indicate whether the system will be trenched or "plowed in" and whether the system will be gravity drained, blown out or a combination.
- i. Set back park water services a minimum of 2.5 m from pathways, hard surfaces and trees, and set back lateral irrigation lines a maximum of 0.5 m from property lines.
- j. Schedule of materials/products describing sizes, manufactures and model numbers, pipe fitting method, performance standards and sources of said materials/products. Approval of the list of materials/products is required prior to the placing of formal orders for them.
- k. Water window is justified by vandalism problems and horticultural requirements. The park water service maximum site sizes are:

Park Water Service	Maximum Size of Site
50 mm	0.83 ha
100 mm	3.02 ha
150 mm	6.79 ha
200 mm	11.17 ha

- l. All pertinent construction details not included in standard specifications.
- m. Design the irrigation system to the minimum static water pressure of the applicable pressure zone. Contact the Parks Department Parks Department to obtain the Static Water Pressure, and indicate the pressure on the plan.
- n. Where the design conflicts with the Standards and Specifications, and the designer wishes approval for an override, identify conflicts and provide an explanation, i.e. "This design overrides specification item 3.3.3 of 'Layout' for the following reasons..."
- o. In order to ensure that the irrigation design will function effectively within the practical water window, completion of the following scheduling chart is required.

Station / Zone	Head Type	Nozzle #	PSI	Flow (GPM)	Precipitation Rate	Slope	Aspect	Soil	Days of Week	# of Cycles	Cycle Time	Sok Time
1	I-25	5#13	56	58	1.575 in/hr.	3:1	South	Clay loam	M-W-F	3	10 min	45 min
2												
3												

The following are the water requirements and limitations for Calgary and area as per current data. The maximum ET measured during the last couple of weeks in July and the first two in August is 0.183 inches per day or 1.281 inches per week (Based on Environment Canada 30-year data). The daily watering window is from 1:00 AM till 6:00 AM. For the health of the plants and to promote good root growth, each zone cannot operate more than once every second day.

3.3 UTILITY AND PIPELINE LOCATION CONTACT NUMBERS

Prior to the commencement of any work, the contractor is responsible to contact the appropriate agencies as required including those not listed in the list below (Field Location and Emergency Service) to locate existing underground utilities and pipelines in or adjacent to the construction work site. The utility or pipeline agencies must be contacted two (2) working days in advance of commencement of work.

3.3.1 EXCAVATION PERMITS

Prior to any excavation in public ROWs, excavation permits must be obtained from The City of Chestermere.

3.3.2 FIELD LOCATION & EMERGENCY SERVICE

If you accidentally damage the coating or scrape, sever or rupture any underground line, please call the appropriate service immediately. Watch for aboveground structures such as utility pedestals, power lines and hydrants that are located in roadways, lanes and private property. If they are damaged please report the incident immediately.

Emergency Calls -24 HR. Service

ATCO		245.7222
EPCOR (Water & Sewer)	207.4503 After Hours	1.888.775.6677
FORTIS		403.310.9473
TELUS		611
Shaw		310.SHAW

3.4 PERMISSION TO USE WATER FOR CONSTRUCTION

Refer to the current edition of The City of Chestermere Engineering Design and Construction Standards. www.chestermere.ca.

3.5 INSPECTIONS

Inspections by The City of Chestermere Parks Department are required at key times during project construction as outlined in each section of the Standard Specifications for Landscape Construction. Requests can be met by calling The City of Chestermere Parks Department.

Satisfactory construction inspections will be recorded on a "Construction Inspection Checklist". The City of Chestermere Parks Department shall be given a minimum of 24 hours written notice when requesting an inspection via email.

As per the Inspection Checklist tables, landscape and irrigation inspections for: interim development; Construction Completion Certificates; or Final Acceptance Certificates will only occur during regular business hours. **NOTE: Landscape Inspections are Monday – Friday from 8:30am – 3pm**

Final Acceptance Certificates submitted after September 1st for sites with an irrigation system will require the area irrigation foreman, or designate, present during the winterization procedure. The areas will ensure staff will be available with 48 hours notice. As an alternate, the area staff will not be required on site during the winterization procedure provided the Developer agrees, in writing, to start the system and perform any repairs that may be required the following spring.

Failure to notify the appropriate inspection service may require all work to be exposed for an inspection at the developers' expense. **NOTE:** *Inspectors will not review site development unless stamped approved drawings are available on site.*

3.6 CONSTRUCTION COMPLETION CERTIFICATES (CCC)

- a. Landscaping for Reserve Parcels (i.e. sub-neighbourhood parks, linear parks and those portions of neighbourhood, community and district parks designated as decorative parks, ornamental parks and tot lots), public utility lots, ROW's, boulevards, medians, traffic islands and storm water facilities shall be considered "complete" or "completed" when all underground irrigation and water services have been installed, tested and inspected and preliminary "as constructed" drawings have been submitted to The City of Chestermere Parks Department and the Reserve Parcels, public utility lots, ROW's, boulevards, medians, traffic islands and storm water facilities have been graded, loamed, seeded or sodded, the trees have been planted and, if applicable, the paved or interlocking stone walkways, fencing, play equipment and amenities have been constructed in accordance with The City of Chestermere Landscape Standards and Specifications Manual.
- b. Park inspections will happen during the minimum five critical stages (as per CCC Construction Inspection Schedules). At the start up meeting the consultant and inspector can determine the appropriate stages based on the design.
 - i. Inspection 1 – Construction Start-up
 - ii. Inspection 2 – Subgrade
 - iii. Inspection 3 – Tree and Shrub Planting
 - iv. Inspection 4 – Irrigation
 - v. Inspection 5 – Finish Grade
- c. The Developer's Consultant, Contractor(s) and the Landscape Inspector will attend each of the above critical stage inspections. **NOTE:** *Each inspection will be initiated by the Developer's Consultant or Contractor. The scope of work to be inspected shall be complete prior to the inspection.*
- d. Essential and non-essential deficiencies will be recorded during each inspection stage and both the Developer's Consultant and the Landscape inspector will sign off on each deficiency repaired during the CCC final field inspection. **NOTE:** *The inspector will bring the checklist to site. The example is in table #9*
- e. Once the field inspection form has been signed by all parties and all work has been completed, the Developer will apply to Parks Department for CCC. Along with that application, the Developer will submit a copy of the signed-off CCC field inspection form noting the expiry date to complete all non-essential work. **NOTE:** *In order to effectively inventory sites once CCC is issued, Parks Department request that the Developer provide the following information on the CCC Application:*
 - Plan No. (registered or tentative)
 - Block No., Lot No. and Type Development Agreement #
 - As build plans for all areas that have changed and irrigation
 - All other required forms, permits, certificates and paperwork submitted to the parks department.

Landscape components submitted for construction completion should be submitted in specific groupings by approved by design packages. The Developer, upon the completion of a reserve parcel, public utility lots, ROW, boulevards, medians, traffic islands or storm-water facilities shall cause to be prepared and issued four (4) copies of a Construction Completion Certificate (CCC) that is duly signed, sealed and certified by the signing officer of the Consultant. The CCC shall also include the projected earliest maintenance expiry date.

- f. The Developer, within thirty (30) days of the issuance of the said CCC shall forward the four (4) copies of the said CCC to The City of Chestermere Parks Department Parks Department for acknowledgment of receipt of same.
- g. The City upon receipt of the said CCC shall within fourteen (14) days acknowledge the receipt of the said CCC.
- h. Parks Inspector and the Parks Manager will sign the landscaping CCC and send a copy to the Developer.

Table 8 - CCC Construction Inspection Schedule

Sub-Neighbourhood, Neighbourhood, Community, and Linear Parks; Employment Centre Open Space; Community Squares; Commercial Plazas; Storm Water Facilities; ROW *NOTE: Approved plans required prior to work. Start Up Meeting will determine site specific construction schedule, this table is for example only.*

Work Inspected	Seasonal Limits	Timing	Percentage (%) Essential Prior to next phase of construction or final CCC
Startup meeting	none	Inspection 1	100
Layout P.L. Stakes	6" frost and/or no snow	Inspection 1	100
Erosion/Sediment Controls	None	Inspection 1	100
Survey Stakes -Grades	6" frost and/or no snow	Inspection 1/2	100
Sub-grade Preparation	6" frost and/or no snow	Inspection 2	100
Site Layout (e.g. pathways, trees, amenities, sport fields, playgrounds)	6" frost and/or no snow	Inspection 2	100
Topsoil Test	None	Inspection 3	100
Finished Grade to Plan and Spec.	Frost Free	Inspection 5	100
Seeding	Frost Free	Inspection 5	100
Sodding	Frost Free	Inspection 5	100
Compaction Reports	None	Inspection 5	Within 60 days of inspection
Line Assignment	None	Inspection 1	100
Tree/Shrubs Pits/Beds	None	Inspection 3	100
Correct Number and Species	None	Inspection 4	100
Root ball/Caliper Standards Met	Frost Free	Inspection 4	100
Trees Planted at Specified Grade	Frost Free	Inspection 4	100
CNLA Specifications Met	Frost Free	Inspection 4	100
Insect/Disease/Damage Free	Active Growth	Inspection 4	100
Set back Spacing	No Snow	Inspection 2/3	100
Burlap Strapping/Wires Removed or Rolled Back	Frost Free	Inspection 3	100
Irrigation			
Plumbing Permit	At irrigation layout	Inspection 2	100
Irrigation Layout	6" frost no snow	Inspection 2	100
Meter Received by Contractor and Meter information sheet is submitted	Sept. 30th or permission from Wastewater	Inspection 4	100
Open Trench Inspection	Frost Free	Inspection 4	100
Two Copies Irrigation As-Builts	None	Inspection 5	Within 60 days of inspection
Annual DCV Report	Within 30 days of start-up	Inspection 5	100
Pathways			
Pathway Alignment	6" frost and/or no snow	Inspection 2	100

To Approved Plan and Specification	No snow	Inspection 5	100
Playgrounds			
To Approved Plan and Specification	No snow	Inspection 5	100
Certificate of Compliance Letter	Prior to CCC	Inspection 5	100



CHESTERMERE

CITY OF CHESTERMERE CONSTRUCTION COMPLETION CERTIFICATE FIELD INSPECTION REPORT

Subdivision, Phase, Description:		
Legal Land Description:		Representative and Contact Information
Developer:		
Consultant:		
Contractor:		
City Inspector:		
Inspection and Task	Approved Date	Comments
#1. Subgrade & Start-up		
Approved Plans and Letter		
Survey grades & PL staked		
Landscape EC.		
Subgrade preparation		
Amenity and hardscape layout		
#2. Irrigation		
Open Trench and layout		
Backfill material		
Cabinet and controller		
Power source complete and charged		
Water source complete		
#3. Finish Grade		
Overland drainage		
Fine grading		
Grade stakes		
Tree pits		
#4. Plantings		
Planted at grade		
Root ball & caliper & pot size to spec		
Baskets & burlap removed / rolled back		
Free of damage, disease & pests		

Aquatics and perennials installed		
Mulch Installed		
#5. Final Inspection		
Seeding and sodding		
Signs Installed - site specific		
Amenity installation and condition		
Fence/hardscape installation & condition		
Required Reports		
Approved landscape plans (presented on site)		
Topsoil tests		
Compaction tests		
Engineer certifications		
Irrigation as built plans and reports		Meter sheet, plumbing permit, Irrigation Information Sheet
Any changes to plans - as built or maps		
Requested as built grades		
CSA compliance letter		
Additional Comments:		
Final Inspection Approval		
CCC Final Inspection Approval Date:		Eligible FAC Date:
Maintenance Term:		Maintenance Class:
Required Signatures		Date Signed:
Developer:		
Consultant:		
Contractor:		
City Inspector:		

105 MARINA RD, CHESTERMERE AB T1X 1V7 | THECITYOFCHESTERMERE.CA

*** White - Consultant Yellow - Contractor Pink - City

3.7 MAINTENANCE PERIOD

- a. The Developer, at no expense to The City, shall maintain over a continuous period: sub-neighbourhood parks; linear parks; those portions of neighbourhood, community and district parks designated as decorative parks, ornamental parks and tot lots; boulevards; medians; traffic islands and public utility lots, ROW for one (1) calendar year. The maintenance standard Class will be indicated on the CCC field inspection report.
- b. The Developer, at no expense to The City, shall maintain storm ponds (MR & PUL) and engineered storm-water wetlands for three (3) years and /or until the combination of Engineering FAC, PUL and MR Landscaping can be coordinated.

3.8 FINAL ACCEPTANCE CERTIFICATES

- b. Not less than three (3) months prior to the maintenance period expiry date, or earlier if weather conditions permit, the Consultant and the Contractor shall inspect the Reserve Parcels (i.e. sub-neighbourhood parks; linear parks; and those portions of neighbourhood, community and district parks designated as decorative parks, ornamental parks and tot lots), public utility lots, ROWs, boulevards, medians, traffic islands or storm ponds, and the Consultant shall ensure that the Contractor corrects all defects and deficiencies due to damage and other causes, except defects or deficiencies caused by the negligence of The City or its agents, employees or servants in the performance of their duties on behalf of The City. Subsequent to the correction of the said defects and deficiencies, the Consultant shall submit to The City four (4) copies of the Final Acceptance Certificate (FAC) duly signed and sealed by a signing officer of the Consultant.
- c. To ensure opportunity for establishment of the site, FAC field inspections are available between June 1 and September 30th. If the CCC was granted after September 30th the earliest FAC application will be accepted the following spring. Minimum 12 months establishment period.
- d. Landscape components submitted for final acceptance should be submitted in the same submissions as the design and CCC approval. The consultant shall make an on-site inspection with the inspector within thirty (30) days of receipt of the FAC deficiency list by The City, and if no advice of defects or deficiencies has been sent to the Developer within that time, the improvement shall be deemed by The City to be completed.

NOTE: *Prior to inspection with the Consultant, the Parks Department may inspect the site, the consultant will be notified and access will be requested.*

- e. If the inspection shows to the satisfaction of The City of Chestermere Parks Department that the improvement is completed and any third-party damages are rectified the Infrastructure Manager shall sign the FAC.
- f. If, however, defects or deficiencies are apparent, the Parks Department will issue a "Final Acceptance Inspection Field Check List and Report" detailing the defects or deficiencies that exist and the Parks Department shall retain the FAC for one (1) month from the date of notification. Only one (1) Inspection Check List and Report will be issued during the inspection process. The Parks Department will record the last day of the one (1) month period on the Inspection Check List and Report under "Application Expiration Date." In the event that the defects or deficiencies are not corrected by the Developer within the one (1) month period, the FAC shall be returned unsigned and the Developer shall correct the defects and deficiencies and subsequently resubmit the FAC. The last date to request an FAC will be September 30th. October 31 will be the last day to approve remedied deficiencies and grant FAC. If deficiencies are not completed a new application can start as early as June 1st of the following year.

- g. If weeds are identified in the initial Final Acceptance Inspection and recorded on the field Check List and herbicide is applied to rectify the deficiency, a biocide application report must be submitted prior to the signing of the FAC. (FAC will only be granted if the weed control has proven successful, the documentation is not the sole requirement for FAC. No noxious weeds can be present.
- h. Boulevard landscaping adjacent to undeveloped lots will require a tree protection plan with the developer at FAC and lot security release will rely on the inspection of the tree for damage. Parks strongly encourages 90% build out prior FAC.
- i. Community and District parks containing MSR sites shall be fully developed and an application for Final Acceptance shall be submitted:
 - i. No later than at least one full year prior to occupancy of a school;
 - ii. By the time 30% of the lots or projected lots located within the catchment area, which is deemed to be all lands located within 1.2 km from the property line of the said parcel of land, are occupied;

All development has to be checked and approved on site by Parks Department prior to signing of the FAC by the City's Parks Department. If defects or deficiencies are apparent, the process will be as per item 'e' above.

Form 3- Final Acceptance Certificate Field Inspection Report- Example



CHESTERMERE

CITY OF CHESTERMERE FINAL ACCEPTANCE CERTIFICATE FIELD INSPECTION REPORT

Subdivision, Phase, Description:			
Legal Land Description:		Representative and Contact Information:	
Developer:			
Consultant:			
Contractor:			
City Inspector:			
Conditions:	Deficiency Y/N	Rectified Y/N	Deficiency Details:
Turf Condition			
Drainage issues, ponding or settlement			
Bare areas			
Free of damage, disease & parasites			
Garbage			
Biocide report			
Plant Material			
Plant material replacements			
Gator bags on replacement trees			
Map of replacement plants for health care program			
Free of damage, disease & parasites			
Pruning required			
Bed & well condition			
Bark base protection wire installed			
Stakes & guy wires removed			
Mulch			
Beds and wells weed free			
Beds and wells edged			
Biocide report			
Irrigation			
Operational from controller & central			
Head coverage			
Water meter information sheet and final tally			
Site ID - power transfer sheet received			
Irrigation information sheet received			
Annual DCV reports received			
Maintenance manuals received			
Amenities			

Benches & garbage receptacles			
Shelters & structures			
Parks information sign condition add / removal			
Fencing and barriers			
Paths and Hard Surfaces			
Damage			
Settlement, cracks, heaving			
Pavers - joint sand / Class surface			
new compaction reports (only for extensive repairs)			
Equipment			
Play surface			
Equipment condition			
Borders and drainage			
HIC test - upon request			
Storm Pond			
Aquatics establishment			
PUL landscaping			
Continued Maintenance			
Pageantry or other reason - attach agreement			
Approval			
FAC Inspection Start Date:		Latest Approval Date:	
Term Length:		Approval Date:	
Required Signatures		Date Signed:	
Developer:			
Consultant:			
Contractor:			
City Inspector:			
Inspection Fail Justification:			
Earliest Reapplication Date:			

Form 4 - Final Acceptance Certificate Application

Subdivision	Phase:
Developer:	Date:
Contractor:	Improvement:
Consulting Landscape Architect:	Boundary of Area: See Attached Map

Consulting Landscaper's Certificate

I, _____, Professional Landscape Architect of the firm of _____, Consulting Landscape Architect's, who are engaged by the Developer to design and inspect the construction and installation of parks, pathway, and other improvements, do hereby certify that the utilities and improvements within the area shown on the attached plan have been constructed, installed and inspected in conformance with the Municipality's specifications and approved designs, or as otherwise required by the Municipality, and that all defects and deficiencies in work and materials have been reported to the Developer and the Municipality and have been remedied by the Developer, and that the park, pathway or other improvement noted herein meets all the requirements for acceptance. I confirm that I have been empowered by the Developer to honour, comply with and perform all of the Consulting Landscape Architect's obligations and to provide all of the services as specified in the current Landscape Standards and Specifications, as issued by the City of Chestermere.

_____, LAT, AALA Consulting Landscaper's Inspector	Stamp / Seal & Signature
---	-----------------------------

Acknowledgement of Receipt of Consulting Landscaper's Certificate:

_____	_____
Municipal Engineer	Date:
_____	_____
City of Chestermere	Date:

Rejection of Consulting Landscaper's Certificate:

_____	_____
Municipal Engineer	Date

Cause for rejection

I hereby certify that the items listed as reason for rejection have now been corrected.

_____	_____
Consulting Landscaper Architect	Date

Acknowledgement of Receipt of Consulting Landscaper's Certificate:

_____	_____
City of Chestermere	Date

Maintenance expiry date:

3.8.1 CRITERIA FOR CONDITIONAL FAC

- a. Maintenance Agreement. If the developer requests the continued maintenance of the site after FAC for any reason they will need to provide a detailed maintenance agreement to be signed prior to FAC.
- b. Marketing signs and flags will not interfere with the FAC process providing the Developer enters into a maintenance agreement with the Parks Department if not already stated in the current development agreement. Either agreement will recognize the responsibility for continued maintenance and repairs to the parcel as well as a map outlining where the signs and marketing items are. The Developer shall provide to The City 30 days notice of their intent to turn the parcel(s) over to The City. Once the signs and/or marketing items have been removed the Developer shall initiate a re-inspection of the property as per the FAC procedure.

Please note:

- Do not include snow and ice management in the contract. Post FAC maintenance agreements will not include pathway maintenance for liability concerns; However, all other maintenance will be required throughout the duration of the contract. (see maintenance standards.)
- The agreement must include the entire parcel or show a clear maintenance delineation, for example: if there are flags in an entry feature, the entire parcel and attached boulevard must be included in the maintenance package. Typically, the area of construction approved for FAC will be considered the area of maintenance in the agreement.
- The contract must be completed prior to the approval of marketing signs or pageantry through The City of Chestermere's Planning Department.

3.9 WARRANTY PERIOD

The warranty period will be extended for an additional twelve months (at time of FAC inspection) when the following conditions apply:

- For sites with more than 40 trees, where 10% or more of the tree root balls have been or are required to be disturbed (lift, lower, straighten, etc.) or where 10% or more are required to be replaced within the current year or
- For sites with 40 trees or less, where 25% or more of the tree root balls have been or are required to be disturbed (lift, lower, straighten, etc.) or where 25% or more are required to be replaced within the current year or
- For sites with 25 shrubs or less, where 50% or more of the total shrubs have not established or
- For sites with more than 25 shrubs, where 25% or more of the total shrubs have not established.

3.10 CCC AND FAC APPEAL PROCESS

The intent is to provide a process by which an appeal can be initiated in the event the CCC or FAC applicant is refused a CCC or FAC. The process is intended to provide a review of the decision based on the contractual obligations associated with the development agreement, and Landscape Standards and Specifications Manual.

Step One: In the event of a refusal by the Parks Inspector, a review will be conducted with the Parks Department Manager, the Developer or their representative. Where agreement or consensus is not achieved, the process will go to Step Two below.

Step Two: In the event consensus is not reached, the refusal will be considered by the Director of Community Services, and the Chief Administrative Officer (CAO). The decision at Step Two will be final.

4 RECREATION FACILITIES & AMENITIES

4.1 RECREATION AND AMENITIES GENERAL DESIGN GUIDELINES

- a. For recreational activities that encourage long term play, ensure shade and water sources are provided.
- b. Arts and culture items are encouraged. Examples: Amphitheaters, interpretive signs, statues.
- c. Permanent outdoor games are encouraged, especially in linear and pocket parks.
- d. When possible, incorporate all seasons into facilities and amenities. Examples: Multiuse courts containing a winter and summer use.
- e. Allow for dual use of facilities. Examples: Combination rugby soccer posts.
- f. All sports and recreation facilities must include corresponding furniture. Examples: Players benches or bleachers.
- g. Buffer residents from facilities using coniferous plantings or other noise barriers.
- h. When facilities are located adjacent to a parking lot, road or area needing containment of play, sections of chain-link fence will be required.
- i. Universal accessibility must be considered to access all recreational possibilities.
- j. Lighting for multiuse courts or winter recreational amenities are encouraged.

4.2 SITE PLANNING TEAM'S JOINT USE SITE GUIDELINES

Table 9 - Site Planning Team's Joint Use - Requirements

Type of School	Joint Use Site Area	School Building Envelope	Sports Field Envelope	Education Sports Filed Requirements	Recreation Sports Field Requirements
Public Elementary School	4 hectares (10 acres)	1.6 hectares (4 acres)	2.4 hectares (6 acres)	2 Minor/1 Major overlapping soccer fields Creative Playground	1 x 76m ball diamond
Public Junior High School	4.9 hectares (12 acres)	1.6 hectares (4 acres)	3.2 hectares (8 acres)	2 Minor/1 Major overlapping soccer fields Field event area	2 x 76m ball diamonds
Public Elementary & Junior High Schools	6.9 hectares (17 acres)	3.2 hectares (8 acres)	3.6 hectares (9 acres)	2 Minor/1 Major overlapping soccer fields Field event area Creative Playground	2 x 76m ball diamonds
Separate Elementary School	3.6 hectares (9 acres)	1.4 hectares (3.5 acres)	2.2 hectares (5.5 acres)	2 Minor/1 Major overlapping soccer fields Creative Playground	1 x 76m ball diamond
Separate Elementary & Junior High School	4.9 hectares (12 acres)	1.9 hectares (4.75 acres)	2.9 hectares (7.25 acres)	2 Minor/1 Major overlapping soccer fields Field event area Creative Playground	1 x 76m ball diamond
Public/ Separate High School	9.2 hectares (23 acres)	4 hectares (10 acres)	5.3 hectares (13 acres)	2 Minor/1 Major overlapping soccer fields 1 Football field Track & field area	2 x 76m ball diamond
Community Association Facility	1.2 -1.6 ha. (3 -4 acres)			Games amenities	1 Multiuse court 2 Tennis courts

NOTE:

- Public Elementary and Junior High School sites will accommodate 2 school buildings.
- All site sizes and building envelopes are minimum requirements. Additional land may be required where physical constraints exist.
- The City of Chestermere no longer supports dry ponds.
- Field Event areas include long jump, shot put, discus, etc.

4.3 HOCKEY RINK

- Hockey rinks are encouraged to be multi use and designed to regulation size.
- Rink surface must be graded flat for water or appropriate for multiuse courts.

4.4 SOCCER FIELDS AND BALL DIAMONDS

- Refer to detail sheets **COCH-LS #2,3,4** for sport field (FIFA playing field specifications take precedence for soccer).
- Combination soccer net and Rugby goal posts must be installed on all major soccer fields. Portable goalposts are encouraged. If portable goalposts are to be installed they must be securely anchored to the ground.
- Irrigation of soccer fields must be designed laterally with minimum six separate zones.

- d. Refer to detail sheets *COCH-LS #8-14* for ball diamond & backstop dimensions.
- e. Shale should extend around chain-link fencing where possible.
- f. All sports fields, and a buffer zone of 3.0 m, are to be graded to achieve a level, playable surface without ponding areas. It is critical to establish adequate surface drainage on soccer fields, or any other athletic field. A 1% slope is preferred on native soil fields and given play conditions. For native soil fields, it is imperative to achieve a 1% slope from the center of the field to both sidelines. The field should be level from end to end, i.e. goal area to goal area. This will make a camber from 9 to 18 inches side to side, along the center of the field depending on the width. A 3.0 m buffer may be graded to a maximum of 2%. For other types of athletic fields, the “Optimal Drainage Patterns for Sports fields” as per detail sheet *COCH-LS #2* may be used. The City of Chestermere Parks Department will consider solutions other than the preferred sports field grading options if site conditions do not permit their execution. Goal end to goal end grading will only be permitted subject to demonstration that no other alternate is available. Only the 3.0 m adjacent to the sports field of the total 10 m buffer is required to be graded level and free of obstacles. The 7.0 m balance of the buffer may include plant material, amenities and back-sloping.
- g. Ball diamonds and soccer fields shall be devoid of all obstacles including catch basins, and they shall be set back a minimum of:
 - 10.0 m from all Property Lines;
 - Tree and shrub setbacks as per Table 13;
 - 20.0 m from playgrounds;
 - 10.0 m behind soccer goal posts; and
 - 3.0 m around the perimeter of ball diamonds and along the sides of soccer fields.
- h. Backstop canopies are required when the back of the backstop faces roadways; residences; other backstops; playgrounds; pathways; and other sports fields.

4.5 TENNIS COURTS

- a. Tennis Courts will be permitted if developed minimally as double courts.
- b. The following guidelines and specifications should be used in conjunction with detail sheets *COCH-LS #15-24*:
 - i. A geotechnical analysis on a maximum 10.0 m grid and to a 2.0 m depth shall be conducted.
 - ii. Any organic or otherwise unsuitable material as determined by the geotechnical analysis shall be removed to a minimum depth of 1.0 m below existing grade and replaced with 1.0 m of 75 mm minus pit run base gravel conforming to the current City of Calgary Roads Construction Specifications. If no organic or otherwise unsuitable material is present, then the subgrade shall be excavated to a minimum depth of 500 mm and back filled with 500 mm of 75 mm minus pit run base gravel conforming to the current City of Calgary Roads Construction Specifications. The subgrade and base gravel shall be compacted to a minimum average of 98% with no single test showing less than 95% of standard Proctor.
 - iii. 100 mm of 20 mm crushed gravel conforming to the current City of Calgary Roads Construction Specifications shall be placed and compacted to a minimum average of 98% with no single test showing less than 95% of standard Proctor.
 - iv. A 60 mm lift of Mix 'B' asphaltic concrete conforming to the current City of Calgary Roads Construction Specifications shall be placed and compacted to a minimum average of 98% with no single test showing less than 95% of standard Proctor.
 - v. A 40 mm lift of mix 'M' asphaltic concrete conforming to the current City of Calgary Roads Construction Specifications shall be placed and compacted to a minimum average of 98% with no single test showing less than 95% of standard Proctor.
 - vi. The entire court surface area will be power washed with a minimum 3000 P.S.I. Power washer to ensure the surface is clean and free of all dirt, oil, and deteriorated coatings. The

contractor is required to remove all debris from the site prior to the commencement of court patching and surfacing.

- vii. Prior to the application of the "Asphalt Resurfacer" (Asphalt Emulsion Filler Course), the contractor shall flood the court surface area with clean potable water in the presence of the Parks Department or designated representative. Any depressions thereupon holding water deeper than 1.25 mm after 45 minutes shall be marked out. These depressions shall then be filled with "Court Patch Binder" (High Strength Acrylic Bonding Liquid Patching Mixture). After appropriate curing time the court surface area will again be flooded as described above to ensure that all reasonable depressions have been filled. If it is determined that more filling is required, filling will be done as described above. The use of asphaltic type emulsions or hot sand mix asphalt to fill depressions is prohibited.
Note: *It is expected on new construction that no depressions will be evident after the final lift of asphalt is laid. On new construction, the asphalt must cure for a minimum of 14 days prior to the application of any surface coating.*
- viii. Upon completion of all depression patching, the contractor shall fill in all surface divots and cracks with "Plexipave Tennis Court Crack Filler" or approved equivalent (highly flexible filler and/or a high strength acrylic bonding liquid patching mixture) as per manufacturers specifications. The entire surface will then be scraped and/or ground to remove all ridges and then be blown clean to remove all loose debris.
- ix. The contractor shall apply one coat of SS1 Asphaltic binder to the entire court surface immediately prior to the first application of asphaltic emulsion filler.
Note: *This step is not required for new construction.*
- x. The contractor shall apply two coats of "Asphalt Resurfacer" (Asphalt Emulsion Filler Course) to the entire court surface as per manufacturers' specifications. The second coat will be applied at a 90-degree angle to the first coat. When the second coat has cured, the surface will be scraped to remove any ridges and then the entire surface will be blown clean to remove all debris. The surface will then be rolled with a double drum mechanical roller.
- xi. The contractor shall apply two coats of "Coloured Fortified Plexipave" or approved equivalent (Fortified Acrylic Coloured Filler Emulsion – utilizing 80-100 mesh rounded sand) – as per manufacturer's specifications. The surface will be scraped and blown between coats as previously described. A final coat of Coloured Plexichrome (Fortified Acrylic Coloured Finish Emulsion) or approved equivalent – as per manufacturer's specifications shall be applied to the entire surface. Colour scheme is to be Green playing pads and Red perimeter – unless otherwise agreed by The City. For multi-use court, colour will be green.
- xii. For multi-use courts, in lieu of "Coloured Fortified Plexipave", the contractor shall apply two coats of "Acrylotex" (Specialized Fortified Acrylic Coloured Filler Emulsion) or approved equivalent, as per manufacturer's specifications. Note: this step only to multi-use surface installations (i.e. basketball/inline hockey surfaces).
- xiii. The contractor will layout, mask and roll court lines as per official dimensions. Two coats of "Plexicolor Textured White Line Paint" or approved equivalent (100% Acrylic Emulsion Line Paint) will be brush applied. All lines shall be straight and true and provide sharp edges. The use of traffic oil, alkyd, or solvent vehicle type paints is prohibited.
- xiv. The contractor will paint the tennis posts with two coats of black epoxy enamel paint (Tremclad or equivalent). New posts will be treated with a light acid wash (acetone, vinegar, etc.) Previously painted posts will have old flaking paint removed prior to painting.
- xv. Fencing: A 3.66 m high chain link fence (38 mm mesh -No. 9 gauge steel) is required and shall be constructed as per The City of Chestermere Landscape Standards and Specifications.

4.6 FOOTBALL FIELDS/TRACK & FIELD AREAS

- a. Football fields/track & field areas and their buffer zones must be graded to eliminate ponding areas and have an optimum gradient of two percent (2%) in all directions with a variance of plus or minus 0.5%.
- b. Grading plans for football field/track & field areas shall illustrate drainage patterns in a minimum of three directions.
- c. Football fields/track & field areas form part of a City Park and are not part of the ten percent (10%) Municipal Reserve Dedication. The School Boards will be responsible for the development of these facilities.
- d. Goal post and field dimensions are on detail sheets *COCH – LS #25 AND 26*. Multipurpose goal posts are strongly encouraged.
- e. The layout for the field events may be varied to suit particular local requirements. Design specifications can be obtained by contacting The City of Chestermere Parks Department.

4.7 BASKETBALL COURTS

- a. Detail sheets *COCH-LS #27-29* are to be used in conjunction with the following specifications:
 - i. Prior to construction of the surfacing a pavement design shall be submitted to The City of Chestermere Parks Department. The pavement design shall be prepared by a qualified geotechnical professional Engineer. The design should be gravel based and shall include a review of existing subsoils and subgrade drainage conditions. Subgrade preparation along with placing and compaction of gravel and asphaltic concrete is to be carried out in accordance with the current City of Calgary Roads Construction Specifications unless otherwise specified in the design.
 - ii. A final asphalt emulsion of two coats should be applied. The application shall include a filling, sealing and texturing process. Then the colouring and lining of courts shall occur with an acrylic emulsion coating. This coating shall be highly pigmented with prime colour and reinforcing pigments that will provide a long and lasting finish for basketball courts.

5 TREES, SHRUBS AND GENERAL PLANTING

5.1 DEVELOPMENT GUIDELINES

5.1.1 DESIGN GUIDELINE

- a. At the discretion of the parks department, no more than 35% of any one species planted in a development phase will be of one species.
- b. If other deciduous trees and coniferous trees are less than 3.5 m from vertical elements and hard surfaces or private property lines the trees must be placed in mulched bed and vertical and horizontal root barrier will be required by hard surfaces.

5.1.2 SETBACK/SPACING GUIDELINES

The following table shows the setback and spacing guidelines for all tree plantings in parks, public utility lots and ROWs:

Table 10 - Tree Plantings - Setback and Spacing Guidelines

A. Setback Situation	Poplar & Willow Trees & Shrubs (except Swedish Aspen)	Other Deciduous Trees	Coniferous Trees
Vertical Elements and Hard Surfaces (root barrier required)	5.0 m	2.0 m	½ maximum spread
Private Property <ul style="list-style-type: none"> • Chain Link Fence • Post & Cable Fence • Wood Screening Fence 	10.0 m	2.0 m	½ maximum spread
Sports Fields	10.0 m	½ maximum spread from 3.0 m buffer	½ maximum spread from 3.0 m buffer
B. Tree Spacing	½ maximum spread from 5.0 m buffer (whichever is less)	½ maximum spread	

Note: The use of Sandbar Willow and other aggressive species will not be accepted in Class 1 or 2 parks or close to hard surfaces.

5.1.3 LINE ASSIGNMENT (I.E. SETBACK) REQUIREMENTS

The following table shows setback requirements for trees planted adjacent to utilities.

Table 11 - Tree Separations to Utilities

Utilities	Poplar		Deciduous			Coniferous		
	Services	Mains	Services		Mains	Services		Mains
		Parallel to tree line	Medians	Blvd.	Parallel to tree line	Medians**	Blvd.	Parallel to tree line
Deep								
Sanitary	N/A	N/A	0.0 m ^{***}	2.5 m	3.0 m		3.0 m*	4.0 m
Storm (<4.5 m deep)	N/A		0.0 m ^{***}	2.5 m	3.0 m		3.0 m*	4.0 m
Water	N/A		0.0 m ^{***}	2.5 m	3.0 m		3.0 m*	4.0 m
Hydrants	N/A		N/A	2.5 m	2.5 m		3.0 m*	4.0 m
Shallow								
ATCO			2.0 m		2.0 m			2.0 m ^{**}
TELUS/S haw			1.5 m		1.5 m			2.0 m ^{**}
FORTIS								
FORTIS			1.5 m		1.5 m			2.0 m ^{**}
Transformers (within Utility Right-Of-Ways)	N/A (Tree planting not permitted within Utility Right-Of-Ways)		N/A (Tree planting not permitted within Utility Right-Of-Ways)			N/A (Tree planting not permitted within Utility Right-Of-Ways)		
Street Light Poles	4.0 m – 5.0 m				Minimum 4.0 m			

NOTES:

* Subject to review and at the discretion of The City of Chestermere Parks Department.

** A 3.0 m separation may be required at the discretion of the utilities.

*** Pipe joints are not permitted on water or sewer services located under medians.

Trees on residential (15 m ROW) boulevards, with no sidewalks, can be planted 1.0 m from driveways. Driveway crossings are to be aligned, where possible, to allow space for tree planting.

Poplar trees can be planted 9.0 m offset when located near overhead wires (FORTIS) (to outside conductor).

5.1.4 BOULEVARD, MEDIANS AND TRAFFIC ISLANDS PLANTINGS

Following the City of Calgary's Complete Street's Guide, the Urban Forestry section provides a table representing the ratio of tree size to volume of soil needed:

Figure 3.6-8: Ratio of tree size to volume. (Source James Urban)

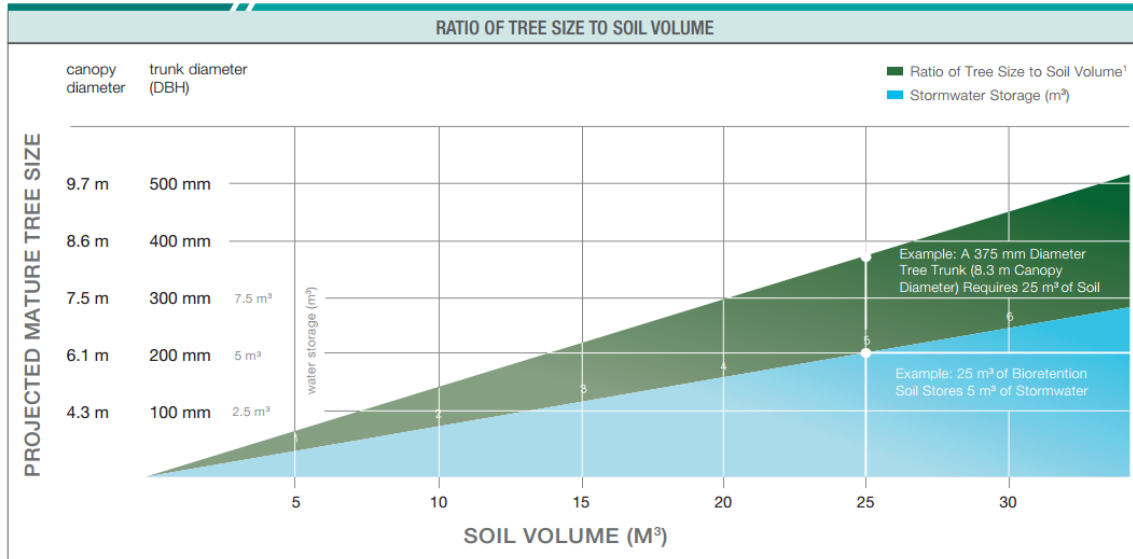

The following are setback requirements for trees and shrubs planted on boulevards and medians:

- Setbacks from corners, driveway aprons, bus stops and traffic signs are to be a minimum of 7.5m for all plantings.
- Mail boxes, furniture and other amenities should have a minimum of 3m setback.
- Medians and boulevards leaving a width less than 2.25m will be not acceptable for tree planting.
- Shrubs and perennials may be considered if designed into Community entry feature or at the Parks Departments discretion upon review of special projects.
- Shrub planting may be permitted at interchanges where gradients exceed 3H:1V.
- Trees bearing fruit that could be considered a nuisance will not be accepted along boulevards and medians.

The following are setback requirements for trees and shrubs planted on traffic islands:

- All trees and shrubs must be a minimum of 7.5 m from the bullnose or back of walk extended through the island, whichever is greater, adjacent to primary streets.
- All trees and shrubs must be a minimum of 4.5 m from 'any' bullnose adjacent to primary streets on irregular shaped islands.
- All trees and shrubs must be a minimum of 3.0 m from the bullnose inside the cul-de-sac.
- All shrubs and deciduous trees (excluding poplars) must be planted 1.5 m from back of curb.
- All coniferous trees must be planted 3.0 m from back of curb (1/2 maximum size for species).

5.1.5 PLAY STRUCTURE PLANTINGS

Shrub beds should be set back from areas designed for play structures as follows:

- a. 3.5 m from the outside edge of the majority of the play area; or
- b. The width of a local pathway where the pathway abuts a play area.
- c. Type and spacing of plantings shall ensure clear sight-lines into the play structure area.

5.1.6 TREE PROTECTION GUIDELINES

The City of Chestermere Tree Protection Plan (under development) contains clauses intended to protect trees growing on Public and Private Land.

As part of the Tree Protection Plan, a Tree Protection Plan will be required when a development or construction activity creates a disturbance on The City Boulevard that is within 6.0 m of a boulevard Tree. A Tree Protection Plan will also be required prior to the issuance of development permits on infill developments and other private lands. The intent of a Protection Plan is to maintain Public Trees as long-term assets to the community and to The City in general. Tree protection requires forethought and planning well before construction activities commence. Tree Protection Plans and protection measures are required on both City of Chestermere owned land and single private developments.

Permits issued by The City of Chestermere Development and Infrastructure Services are required if construction activities use or cross any portion of the road Right-of-Way (including boulevards).

A condition of the issuance of permits by The City of Chestermere Development and Infrastructure Services will be the requirement for a Tree Protection Plan when construction activities are within 6.0 m of a tree on Public land or the protection of trees on private lands. The intent of a Tree Protection Plan is to help ensure that The City's assets remain long term assets to the community. Requirements and specifications for a Tree Protection Plan may be obtained by contacting The City of Chestermere Parks Department

- a. Tree Protection Plan elements, measures and conditions are only required on The City of Chestermere owned land. However, applicants are encouraged to apply tree protection measures on private land. Effective tree protection places limits on damage and disturbance to tree branches, trucks, and root systems.
- b. If plans call for Public Trees to be removed, an application for the removal of Public Trees can be found online at www.chestermere.ca (under development). Public Tree Removals will not be approved without an approved Tree Protection Plan. Completed Tree Protection Plans Referencing Development Permit number, site address and billing information are to be submitted for approval.
- c. A tree protection plan is a drawing and/or report, installation of physical barriers or other materials and specification of construction techniques.

A Tree Protection Report is to:

- Inventory and locate all trees and shrubs on The City of Chestermere owned land within 6.0 m of all property lines of the site under redevelopment.
- Identify species, diameter at 1.4 m off the ground, height, condition and existing flaws or damage, significant pests and diseases.
- Identify whether tree(s) or shrubs are to be moved, removed or protected.
- Identify whether tree pruning is required to provide clearance.
- Identify a Tree Protection Zone in which activities are restricted.
- Minimally, this zone is limited to The City of Chestermere owned land, 4.0 m distance from the trunk and to a depth of 1.2 m. The canopy of the tree is protected to the dripline.
- Locate staging, hoarding, and storage areas of construction.

- Locate limits of land disturbance, excavation, trenching and grade changes, routing of utilities, and irrigation systems, sidewalks, driveways, construction access roads, changes to street lighting, fire hydrants, and utilities boxes.
 - Identify construction methods and equipment to be used on The City of Chestermere owned lands.
 - Identify measures to ensure tree branches, trunk and roots are protected during construction. Measures may include effective barrier fencing, branch and or root pruning, protective mulch, supplementary water, soil aeration, informational signage.
 - Identify pre and post construction tree care measures.
 - Provide contact information for a designated individual (ISA Certified Arborist or consulting arborist) that will be responsible for ensuring all work adheres to the approved Tree Protection Plan.
- d. The City of Chestermere Development and Infrastructure Services prohibits:
- Work on The City of Chestermere owned land within 6.0 m of a Public Tree without a Tree Protection Plan.
 - Construction activities requiring use of or on the road right-of-way without a permit issued by City of Chestermere Parks Department
 - Unauthorized soil disturbance on The City of Chestermere owned land within 6.0 m of a City tree.
 - Unauthorized deviation from a Tree Protection Plan approved by The City of Chestermere Parks Department
 - Unauthorized entry into a Tree Protection Zone or interference with tree protection barriers.
 - The attachment of objects to the trunk or branches.
 - The use of equipment for which there is insufficient canopy clearance.
- e. The City of Chestermere Development and Infrastructure Services requires:
- Work on The City of Chestermere owned lands to be performed by The City of Chestermere forces or by Contractors that have entered into an indemnity agreement with The City of Chestermere.
 - Compensation for trees removed or damaged as per appraisal methodologies accepted by the International Society of Arboriculture and as determined to be fair and reasonable by The City of Chestermere Parks Manager.
- f. Failure to comply with public tree protection measures may result in fines ranging from (under development), in accordance with The City of Chestermere's Tree Protection Plan (under development). Other compliance measures may be required by a duly appointed Enforcement Officer.
- g. The applicant will be required to provide compensation to The City of Chestermere for any Public Trees that are removed or damaged. Individual Public Trees can have values ranging in the thousands of dollars depending on size and species. You may wish to consider this cost during the design and development phase of your project. Applicants that are unfamiliar with tree protection or tree appraisal must consult a certified arborist or tree service.
- h. The applicant shall provide compensation to The City for trees removed as per the approved Tree Protection Plan.
- i. All trees and landscaping on public land shall be established and receive construction inspections in accordance with the current edition of the City of Chestermere's Landscape Guidelines and Landscape Standards and Specification Manual.

5.1.7 TREE REPLACEMENT/COMPENSATION GUIDELINES

- a. If anyone receives approval from The City of Chestermere Community Operations to remove trees from public lands and they plant replacement trees, they must plant replacement trees based on the City of Chestermere Tree Protection Plan (under development), Open Space Policy, Land Use Plan, or any other City Plan or Policy requirement. Based on the size of the tree a 2:1 replacement compensation ratio may be imposed.
- b. If anyone receives approval from The City of Chestermere Development and Infrastructure Services to remove trees from public lands and there are plans for replacement, they shall pay to The City the difference (if applicable) between the cost of the replacements and the value of the trees to be removed as determined by the Parks Department, using the International Society of Arboriculture's (ISA) formula.
- c. If anyone removes or damages trees on public lands or private lands, without the approval of The City of Chestermere Development and Infrastructure Services, while performing a City infrastructure works project, they shall replace the trees in accordance with the two trees for every one tree removed or destroyed formula.
- d. If anyone removes or damages **Native Vegetation** in any of the above three scenarios, the replacement of the vegetation will be evaluated on a site-by-site basis to ensure that the integrity of the site's vegetation is reasonably maintained.

5.1.8 SHRUB AND PERENNIAL PLANTING GUIDELINES

- g. Parks: Plantings to be approved on a site-by-site basis.
 - i. Are utilitarian;
 - ii. Do not cause excess maintenance requirements;
 - iii. Do not restrict the visibility between pedestrians and vehicles;
 - iv. Are not in conflict with utilities; and
 - v. Are of a suitable species and growth habit.
- h. Utility Easements & Right-of-Ways on Private Lots: No shrub planting permitted unless otherwise approved by the City's Parks Department.
- i. Planting bed locations should accommodate the use of large turf maintenance equipment. Provide a minimum 2.5m clearance between the edge of a bed and obstructions such as fencing, furniture, buildings, individual trees etc. Where possible, shrub beds should be designed with tapered or flowing edges (no 90-degree corners) to allow for ease of mowing, and eliminate the need for hand trimming.
- j. Perennials are not generally accepted in MR's, line assignments, PULs, Storm ponds and any other open space. Perennials around Entry Features and other special projects will be considered; species and quantities will be approved by the Parks Department.
- k. Aquatics will be reviewed on a case by case basis and approved by the City of Chestermere on Landscape Planting Plans in the case where shoreline water will not fluctuate.

5.2 STANDARD SPECIFICATIONS

5.2.1 DESCRIPTION AND QUALITY ASSURANCE

- a. This section specifies the supply and planting of trees, shrubs, perennials and ground covers.
- b. Planting work is to be carried out by experienced personnel under the direction of an ISA Certified Arborist or CNTA Technician. The contractor will be required to file proof in writing of this experience prior to installation with the City of Chestermere Parks Department Parks Department.

5.2.2 PRODUCT DELIVERY, STORAGE AND HANDLING

- a. Supply manufactured items such as fertilizer, bone meal, mulch, etc. in standard containers, clearly indicating contents, weight, component analysis, and the name of the manufacturer. Include WHMIS codes as required.
- b. Store manufactured materials, subject to deterioration, in a weatherproof place on site and in such a manner that their effectiveness is not impaired.
- c. Provide root balls of the following minimum sizes to meet the corresponding tree size:
 - i. **Hand Planting:**

Table 12 - Minimum Root Ball Size for Trees (CNLA Standard) - Hand Planting

<i>Deciduous Trees</i>	<i>Caliper</i>	<i>Root Ball Diameter</i>
	# 40 mm (1.5")	600 mm (2'0")
<i>Coniferous Trees</i>	<i>Height</i>	<i>Root ball Diameter</i>
	1.0 m (3.28') – 1.5 m (4.92')	600 mm (2'.0")
Root ball sizes for naturalized plantings will be approved by The City of Chestermere Parks Department on a site-by-site basis.		
Provide root ball depth as follows:	<i>Root Ball Diameter</i>	<i>Root Ball Depth</i>
	600 mm (2'0") or less	Minimum 450 mm
Wrap root balls according to the following schedule:	<i>Root Ball Diameter</i>	<i>Wrapping Schedule</i>
	Up to 600 mm (2'0")	142g (5oz.) hessian burlap, single wrap
Bare root stock to not exceed 40 mm (1.5") caliper. Root Ball diameter will be 300 mm (12") for every 25 mm (1") caliper.		

- ii. **For trees dug by tree spade (machine method):**

Table 13 - Minimum Root Ball Size for Deciduous Trees (CNLA Standard) - Machine Planting

<i>Caliper</i>	<i>Ball Diameter</i>	<i>Ball Depth</i>
40 mm	60 cm	40 cm
50 – 60 mm	70 cm	40 cm
70 mm	80 cm	50 cm
80 mm	90 cm	50 cm
90 mm	90 cm	50 cm
100 mm	100 cm	50 cm
125 mm	120 cm	80 cm
150 mm	150 cm	80 cm
175 mm	175 cm	80 cm
200 mm	200 cm	80 cm

- These root ball sizes are considered minimum and will only be used for trees grown under proper nursery conditions (i.e. transplanted or root pruned at least once within previous four years).
- Multi-stem trees will require a root ball at least one size larger.

Table 14 - Minimum Root Ball Size for Coniferous Trees (CNLA Standard)

Height	Root Ball Size	Height	Root Ball Size
50 cm	30 cm	200 cm	80 cm
60 cm	35 cm	225 cm	90 cm
80 cm	40 cm	250 cm	90 cm
100 cm	45 cm	275 cm	100 cm
125 cm	50 cm	300 cm	122 cm
150 cm	60 cm	350 cm	127 cm
175 cm	70 cm		

- These root ball sizes are considered minimum and will only be used for trees grown under proper nursery conditions (i.e. transplanted or root pruned at least once within previous four years).
 - Root ball shall be burlapped and wire-basketed. Wire basket shall be laced at the top and of sufficient strength to withstand lifting the tree by the top loops of the basket at a minimum of two points.
- Cut all roots cleanly when digging plants. Roots should be cut even with the edges of the root ball.
 - Protect plant material from damage and breakage. Protect all parts of plant material from drying out and maintain adequate moisture levels.
 - Ensure that during transport, plant material is adequately protected.
 - Carefully tie in all branches before transporting.
 - Pad all points of contact between plant material, equipment and basket.
 - Heel in with soil or other suitable material and water any plant material that cannot be planted during the current day's operations. All plant material should be planted within 24 hours of delivery to site. The City of Chestermere Parks Department reserves the right to reject any material not installed within this timeframe, weather permitting.
 - Keep all roots and root balls watered prior to planting.
 - Nursery grown deciduous trees that are 100 mm caliper or larger and coniferous trees that are 3.0 - 4.0 m high or taller will require a warranty and a five (5) year maintenance period. The five (5) year maintenance period is calculated from the date of issuance of CCC.
 - Avoid purchasing material with encircling roots.
 - Root ball sizes for naturalized and natural area plantings will be approved by The City of Chestermere Parks Department on a site-by-site basis.

5.2.3 JOB CONDITIONS/SUBSTITUTIONS

- Proceed with planting operations during suitable weather conditions or at the discretion of The City of Chestermere Parks Department.
- Supply and install plant material as specified on the plant list. Substitution with other plant material will be allowed only with the written approval of The City of Chestermere Parks Department.

5.2.4 INSPECTIONS

- a. The Contractor shall have an approved set of drawings and specifications and an approved line assignment available on site prior to calling The City of Chestermere Parks Department for an inspection.
- b. Make plant material available for inspection at source by The City of Chestermere Parks Department.
- c. Approval of plant material at source will not impair the right of The City of Chestermere Parks Department to inspect plants upon arrival on the site or during the course of construction and to reject plants which have been damaged, or which in any way do not conform to the specifications.
- d. Give timely notice (see 3.6 Inspections) to The City of Chestermere Parks Department when inspection and acceptance are required. Inspections shall be requested:
 - i. When holes or wells have been excavated;
 - ii. When baskets are cut back or removed.
 - iii. When all work is complete.
- e. Plant material at CCC and FAC: true to name and type; structurally sound; well branched; healthy and vigorous and free from disease, insect infestations, rodent damage, sun scald, frost cracks, and other untreated abrasions to the bark; and densely foliated with a healthy, well developed root system. Pruning wounds must show vigorous callus growth on all edges and all parts must show live and green cambium tissue when cut. Final inspection of all plant material will be made at the end of the specified guarantee period.
- f. All stakes must be removed from trees.
- g. Animal protection wire is to be placed on all trees in PUL by storm ponds or in the general vicinity of water at the time of FAC. 1" square mesh stucco wire fence, 14 gauge held together by all-weather heavy-duty zip ties. Wire shall be minimum 800mm tall leaving 150mm space around the trunk. . Refer to the current version of *Calgary Parks 2019 Development Guidelines and Standard Specifications: Landscape Construction* for detail sheet no 27b Individual Tree Beaver / Rabbit Protection Fencing. If a tree is replaced at FAC and requires a water bag, the water bag will take precedence over the animal control wire.
- h. Mechanical protection wire is to be placed on all deciduous trees, in standalone tree wells, in maintained areas. 1" square mesh stucco wire fence, 14 gauge held together by all-weather heavy-duty zip ties. Wire shall be minimum 300mm tall leaving 150mm space around the trunk. If a tree is replaced at FAC and requires a water bag, the water bag will take precedence over the mechanical control wire. The standard is the same as the animal protection fence only shorter and smaller gauges are acceptable.
- i. Trees replaced at FAC with no establishment period will be noted on a plan and submitted as part of the FAC requirements. Water bags will be requested on each new tree for the increased plant health care program requirements.

5.2.5 PLANT MATERIAL

- a. Trees will comply with the Canadian Nursery Certification Institute's Phytosanitary Certification Program standards (DPCP).
- b. As a minimum, all plant material must be nursery grown and meet the specifications set out in the latest Guide Specifications for Nursery Stock prepared by the Canadian Nursery Trade Association (CNTA) and the International Society of Arboriculture (ISA) for size, height, spread, grading, quality, and method of cultivation.
- c. Nomenclature of specified plants shall conform to the International Code of Nomenclature for Cultivated Plants and the latest edition of Standardized Plant Names.

- d. Any plant material not conforming to CNLA standards and specifications and/or not grown according to good nursery practices will be designated as "collected plants".
- e. "Collected plants" may only be used when approved in writing by The City of Chestermere Parks Department. "Collected plants" must be of good health and free of pests and diseases.
- f. All material must conform to the sizes shown on the plant list. Larger material may be used only when approved by The City of Chestermere Parks Department. Use of larger plants will not increase the contract price but may affect the warranty period.

5.2.6 MULCH

- a. All the planting beds, vaults, and wells shall be mulched.
- b. Materials:
 - i. *Type:* Spruce and Pine mulch is preferred, any other considerations must be natural wood and not chemically treated or is salvaged from construction lumber, building demolition, or shipping waste. Tinted or coloured mulch will not be considered.
 - ii. *Size:* Coarsely ground mulch is preferred; otherwise use an even mixture in a range of sizes from 10 x 10 x 5 mm to 40 x 60 x 35 mm.
 - iii. *Consistency:* Material should have no more than five percent (5%) by volume of soil, sawdust, peat moss, or needles.
Note: *The best material is pulled out of piles that have composted for a year.*
 - iv. *Sanitation:* No mulch from diseased or infested plant material is allowed unless it can be shown the material presents no risk to tree health.
 - v. *Substitutions:* All mulch and bed coverage types require the approval of The City of Chestermere Parks Department. Approval criteria will include:

• Safety	• Aesthetics	• Durability
• Rate of Decomposition	• Ease of Renewal and Replacement	• Breakdown Products
• Resistance to salts and solvents	• Recyclability	• Permeability
• Soil structure, biology, and how unfavourable impacts will be mitigated	• Irrigation locations	• Impact on water retention
 - vi. *Application:* 75 mm deep. Keep material 50 mm away from trunks and stems to prevent rotting of bark.
 - vii. *Fabric:* Landscape fabric will only be considered under aggregates or other materials that may have soil contamination concerns and to be approved by the City of Chestermere.

5.2.7 PREPARATION

- a. Obtain the approval of The City of Chestermere Parks Department for all planting excavations prior to commencing planting operations. Parks Department approval does not preclude the applicant obtaining his or her approvals as may be required by other City departments, utility providers, or regulators.
- b. All necessary permits, approvals and plants must be available on site including but not limited to utility locates, line assignments, street use and excavation permits, and Parks Department' approved construction plans.
- c. Tree hole excavations exposing utilities including irrigation must be inspected by the utility owner. Utility inspection contacts can be found on Alberta One-Call locate sheet. Inspections of owned irrigation can be arranged.

- d. Supply plant material as specified on the plant list or substitutions as approved by The City of Chestermere Parks Department.
- e. Dig material, specified "B.R." (bare root) on the plant list, while in a dormant state and with the root system extending a minimum of 300 mm (12") diameter per 25 mm (1") of tree caliper. Immediately after digging, wrap the roots in wet burlap and keep burlap wet during transport and storage.
- f. Provide material, specified "W.B." (wire-basketed and burlapped) to Canadian Nursery Landscape Association (CNLA) specifications.
NOTE: See Table 17 and Table 18 for root ball size.
- g. Do not use plant material on which the root ball has been cracked or broken preparatory to or during the planting process.
- h. Container stock to be Canadian Nursery Landscape Association (CNLA) specifications.

5.2.8 INSTALLATION

- a. The following specifications are to be referred to with detail sheet [COCH-LS #30-37](#).
- b. Dig out by tree spade, backhoe or hand shovel, the tree holes and shrub beds and remove excess soil off site. All methods are acceptable as long as there is no glazing of the soil prior to planting.
- c. Ensure width of all planting excavations is 450 mm greater on all sides than the width of the root ball or as per site conditions to maintain soil volume. Scarify subgrade to a depth of 75 mm under all tree pits and shrub beds.
- d. Depth of planting beds are as follows:
 - 450 mm for flower beds
 - 600 mm for shrub beds
- e. Place plant plumb in the centre of the planting pit with a firm base under the root ball. Face the plant to give the best appearance or relationship to adjacent structures. Grafted trees should be planted at root crown depth. The graft shall be above soil grade. Trees are to be planted with root crown at grade or above.
- f. Place bare root plants so that the roots lie in a natural position. Container grown trees are to have the root crown exposed from excess potting soil. Encircling roots are to be separated or cut and laid out radially from the root crown.
- g. At the time of planting, cut away the strappings and remove the top 1/3 of the wire and burlap. Leave two wire handles intact during the maintenance period. Remove these wire handles to the first wire ring prior to final acceptance.
- h. Backfill with topsoil or other material as specified by The City of Chestermere Parks Department and firmly compact the soil to ensure the plant retains its orientation. Ensure no air pockets remain around the roots.
- i. Thoroughly water within the same working day of planting trees. Water probing is not acceptable.
- j. Ensure that the trees remain at grade surrounded by a tree well to a depth of 100 mm after planting and watering. All trees to be mulched starting 50 mm from the root flare (trunk) and extending the length of the hole.

5.2.9 MAINTENANCE/PRUNING/CLEAN-UP

- a. Maintain all plant material from the time of planting until the date of issue of Final Acceptance Certificate.

- b. Maintenance shall include all measures necessary to establish and maintain all plants in a vigorous and healthy growing condition, as specified in Chapter 10 Landscape Maintenance.
- c. At the time of acceptance, all material must be in a healthy, vigorous growing condition. Unmulched beds and tree pits must be freshly cultivated and free of weeds, rubbish, and debris. Mulched beds should be free of weeds, rubbish and debris.
- d. Remove all dead branches. If there is a double leader, shorten one by about 1/2, back to a live branch that points away from the trees that is about 1/3 the diameter of the leader cut. Prune broken portions of branches back to live lateral.
- e. Ensure that all damage to surrounding work is repaired before leaving site.
- f. Each day ensure that all debris is cleaned up and disposed off site and that the project site is left in a tidy, organized condition.

5.2.10 TRANSPLANTING EXISTING TREES

Transplanting trees is not recommended by Parks, if approved the transplant would require a warranty of minimum two years. Transplants follow general tree planting specifications 5.2.6 Mulch, 5.2.7 Preparation, 5.2.8 Installation, and 5.2.9 Maintenance/Pruning/Clean-up.

5.2.11 PRUNING

The International Society of Arborists (ISA) outlines the acceptable reasons for pruning trees as well as prohibited reasons:

- a. Acceptable reasons for tree pruning
 - i. Overhead utility clearance
 - ii. Public Safety
 - iii. Tree health
 - iv. Tree structure
- b. Prohibited reasons for tree pruning
 - i. Mitigation of minor nuisances such as fruit, seeds, fluff, pollen, sticky bud caps, leaves, minor pest infestation, etc.
 - ii. Mitigation of landscape damage
 - iii. Creation of views and clearance of advertising signs.
- c. Tree pruning is to be in accordance with the best practices as published by the International Society of Arboriculture.
- d. Branch removal should be limited to necessary clearance pruning for public and electrical safety, the removal of dead, diseased and defective wood to improve tree health and/or structure.
- e. Trees are to be pruned and maintained in accordance with Illuminating Engineering Society of North America standards for Roadway Lighting.
- f. Public trees interfering with overhead power lines will be pruned or removed as appropriate.

6 SUBGRADE, TOPSOIL, SODDING, AND SEEDING

6.1 SUBGRADE AND TOPSOIL

6.1.1 DESIGN GUIDELINES

- a. Provide a minimum of 2% gradient across all reserve parcels, medians, traffic islands, boulevards, public utility lots/ROWs and storm water ponds;
 - Excessive fill that compromises the site design will not be acceptable;
- b. If non-engineered fill is to be incorporated in any site, the non-engineered fill drawing, documenting the limit and depth of the fill area and confirming the fill area is outside the building envelope, shall be provided at CCC. Refer to the current versions of *Calgary Parks 2019 Development Guidelines and Standard Specifications: Landscape Construction* Detail sheet #28a for non-engineered fill drawing requirements.
- c. Geotechnical testing may be required where questionable subgrade exists; and
- d. Joint Use Site Guidelines:
 - School building envelope to have same grade as sports field envelope (i.e. 2%);
 - School building envelopes and adjacent road grades must be at the same elevation;
 - School building envelope is to have topsoil applied to a maximum depth of 150 mm;
 - For every 1.0 m in elevation in excess of 2% slope, a minimum increase of 3.0 m will be required on site; and

6.1.2 DRAINAGE GUIDELINES

- a. Where possible drainage is to be picked up within the reserve parcels, public utility lots/ROW's and storm-water ponds in grass swales;
- b. Grass swales are to drain at a minimum two percent (2%) gradient;
- c. Grass swales exceeding 60 m runs are to have a minimum gradient of four percent (4%). If the swale is to drain at less than four percent (4%), it shall have concrete swale along the entire length of the swale tied into a catch basin or water drainage along a concrete swale or an approved equal;
- d. The City of Chestermere Development and Infrastructure Services reserves the right to limit the amount of off-site drainage onto a Reserve Parcel and Public Utility Lot/ROW when, in their opinion, such drainage will compromise the integrity of the site;
- e. All trap lows must be approved by The City of Chestermere Development and Infrastructure Services prior to construction. Trap lows must not compromise the use of the site and must be an integral part of the design; and
- f. All drainage swales that empty onto reserve parcels, boulevards, public utility lots, ROWs, environmental reserves, and storm-water dry ponds shall have concrete splash pads (detail sheet *COCH-LS #64*). Concrete splash pads shall be installed at a minimum two percent (2%) pitch for sufficient drainage and maximum ten percent (10%) pitch or erosion fabric will be required at their end.

6.1.3 DESCRIPTION AND QUALITY ASSURANCE

This section specifies the preparation of subgrade and supply and spreading of topsoil. The Contractor must have experience at performing this type and scale of work and will be required to file proof in writing of this experience prior to installation with the City of Chestermere Parks Department Parks Department.

6.1.4 SUBMITTALS

Submit required sample of topsoil to the testing laboratory and indicate intended use, type of mulches to be applied, type of sub-soil and quality of drainage.

6.1.5 PRODUCT DELIVERY, STORAGE, AND HANDLING

- a. Stockpile topsoil in locations designated by The City of Chestermere; and
- b. Do not spread or work topsoil in a muddy condition.

6.1.6 JOB CONDITIONS AND PROTECTION

- a. Report in writing to The City of Chestermere Parks Department Parks Department, prior to commencing work, any conditions or defects encountered on site upon which the work of this section depends, and which may adversely affect the performance of the work;
- b. Do not commence work until such conditions or defects have been investigated and corrected;
- c. Commencement of work implies acceptance of surface conditions and no claims for damages or extra work will be accepted, except where such conditions cannot be determined prior to construction; and
- d. Protect all existing trees and planting areas in accordance to the Tree Protection Plan No.____ (under development).

6.1.7 INSPECTIONS AND TOPSOIL TEST

- a. The Contractor shall have an approved set of drawings and specifications available prior to calling The City of Chestermere Parks Department for inspection.
- b. Obtain approval of the topsoil in writing from The City of Chestermere Parks Department Parks Department. Topsoil testing shall be done on the source of topsoil. Four samples shall be taken (i.e., one within every 25% vertical increment of the stockpile) at a depth of one foot. The location of the samples within each vertical increment shall be determined by the Parks Department.
- c. Submit for approval from The City of Chestermere Parks Department Parks Department the name of the testing company who will conduct the soil analysis.
- d. Submit two (2) copies of the soil analysis report, including the location of the topsoil stockpile or source, summary report and recommendations for correction to The City of Chestermere Parks Department Parks Department. Test the topsoil for NPK, a particle size analysis, soluble salt content, organic matter and PH. Any dangerous contents or ranges should be stated and proven remedied prior to Parks submission. Recommendations should clearly state the type, quantity and application procedure for amendment.
- e. Should the source of topsoil be exhausted, test topsoil from new source, submit soil analysis report and recommendations for correction and obtain the approval of The City of Chestermere Parks Department Parks Department before using.

- f. The City of Chestermere Parks Department shall approve both rough grade prior to placing of topsoil and finished grade at appropriate times before the Contractor proceeds with next phase of work. For all joint use sites and community parks containing sports fields in MR and MSR site the Contractor shall:
- Supply grade stakes at all corners of sports fields as well as along their centre line;
 - Supply grade stakes at the toe and heel of all slopes and swales. Spacing of the stakes is to be determined by The City of Chestermere Parks Department Parks Department prior to their installation; and
- ii. Be available for a joint site inspection with The City of Chestermere Parks Department Parks Department and have on site a survey crew fully equipped to provide any additional elevations as may be requested. At Finished Grade Inspection:
- Supply grade stakes at the corners, centre and quarter points of sports field, break of slopes and along drainage channels.

NOTE: The information to be provided by the Developer on the grade stakes, if so requested by The City of Chestermere, shall include but not be limited to:

- *Offset Distance (if applicable)*
- *Grid Points (if applicable)*
- *Actual Elevations*
- *Cuts/Fills*

The Developer of any adjacent undeveloped lands shall be responsible to match these final design elevations to the satisfaction of The City of Chestermere.

6.1.8 MATERIALS (DETAIL SHEET COCH-LS #38)

- a. "Topsoil": A fertile, friable, natural loam, containing not less than four percent (4%) organic matter for clay loams and not less than two percent (2%) organic matter for sandy loams to a maximum of 15%; and capable of sustaining vigorous plant growth, free of rocks of 50 mm in diameter and over, subsoil contamination, roots and weeds (as determined by The City of Chestermere Parks Department and having a pH ranging from 7.0 to 8.5).
- b. Volume of rock in topsoil not to exceed 20%.
- c. Native soils should be used where restoration is required of natural areas and environmental reserves. The organic layer ('A' horizon) should be stripped and stockpiled. Imported loam should only be used at the discretion of The City of Chestermere Parks Department.

6.1.9 SUBGRADE PREPARATION (DETAIL SHEET COCH-LS #38)

- a. Fine grade subgrade to even running and given levels with a tolerance of plus or minus 75 mm. Remove all debris from the subgrade and ensure it is not contaminated and free of all deleterious materials
- b. Compact finished subgrade and all fill material to 85% standard proctor Dry Density for areas under turf or planting; and
- c. Scarify subgrade to a depth of 75 mm in all areas except where considered impractical by the City. Whenever compaction is greater than or equal to 95% standard proctor dry density scarification will be required to 200 mm.

6.1.10 SPREADING OF TOPSOIL

- a. Spread dry topsoil during dry weather over approved subgrade.
- b. Apply topsoil to the following minimum depths measured at right angles to the subgrade after leveling with a tolerance of 25 mm over a distance of 2.4 m:
 - 300 mm for seeded areas
 - 300 mm for sodded areas (sport fields can be 150mm) state on design.

- 450 mm for flower beds – raised beds 350 mm above existing grade
 - 600 mm for shrub beds – raised beds 300 mm above existing grade
- c. Fine grade topsoil eliminating rough and low areas and to ensure positive drainage;
 - d. Ensure that finished grade meets flush at surface structures, project boundaries and property lines;
 - e. Rake topsoil to obtain even running and given levels and remove surface rock. (detail sheet COCH-LS #38);
 - f. Make good any damage caused by topsoil spreading activities;
 - g. Control dust so as to have no impact on surrounding land uses; and
 - h. Clean all adjacent walks, streets and properties as a result of work done under this section at the end of each working day or as directed.

6.1.11 SPREADING OF TOPSOIL – NATURAL AREAS OR REMEDIATION,

- a. See above 6.1.10 Spreading of Topsoil, subsections a, d, f, g and h (above);
- b. In restoration the depth and finish grade of the topsoil should be tied to the depths and finish of the pre-existing native profile. This should be specified in the restoration plan and approved by The City of Chestermere Parks Department; and
- c. Rough grade topsoil to ensure positive drainage and to emulate the pre-development drainage patterns and rates.

6.2 SODDING

6.2.1 DESCRIPTION AND QUALITY ASSURANCE

This section specifies the supply and placing of cultivated sod. The Contractor must have experience at performing this type and scale of work and will be required to file proof in writing of this experience prior to installation with The City of Chestermere Parks Department Parks Department.

6.2.2 PRODUCT DELIVERY, STORAGE, AND HANDLING

- a. Cut sod by approved methods in accordance with recommendations of the Canadian Nursery Landscape Association (CNLA).
- b. Roll or fold sod prior to lifting, in such a manner as to prevent tearing or breaking.
- c. Protect sod during transportation to prevent drying out and ensure its arrival at the site in a fresh and healthy condition.
- d. Sod should be installed upon arrival. If there is a delay in installation due to weather, keep the sod moist and cool and protected from direct exposure to the sun until installation. The-City of Chestermere Parks Department will reject sod that has dried out.
- e. For new turf a brand type 10-10-10 ratio is to be used and application rates as recommended by the manufacturer.

6.2.3 INSPECTIONS

- a. The Contractor shall have an approved set of drawings and specifications available prior to calling The City of Chestermere Parks Department for an inspection.
- b. Make all materials, including sod, available for inspection upon arrival on the site, or at source of supply when requested. Also, verify names of suppliers when requested.
- c. Give timely notice (see 3.6 Inspections) when materials are available for inspection.

- d. Obtain approval of finished topsoil surface by The City of Chestermere Parks Department before proceeding with sodding.
- e. The City of Chestermere Parks Department reserves the right to reject sod after it has been installed if: the sod does not conform to the specification and/or drawings; each grass species within the sod does not show signs of survival; the root system is not strong and fibrous; the sod is not free of stones; or if the sod shows signs of burned or bare spots.
- f. Remove all rejected materials immediately from the site.

6.2.4 MATERIALS

- a. *Number One Kentucky Bluegrass-Fescue Sod*: Good quality blue grass and fescue mix suitable for the Alberta climate;
- b. *Fertilizer*: Type and application rate to be determined by soil test.
- c. *Wooden pegs or approved equal*: ensure pegs are long enough to securely anchor sod.

6.2.5 PREPARATION AND INSTALLATION (DETAIL SHEET COCH-LS #39)

- a. Proceed with sodding operation only during favourable weather conditions and in accordance with good horticultural practice.
- b. Apply slow release fertilizer type and application rate determined by a soil test analysis. This is subject to adjustment upon time of year and receipt of the topsoil analysis report and the Contractor's recommendation as outlined in [6.1.7 Inspections and Topsoil Test](#).
- c. Provide a finished topsoil surface that is smooth and firm with a fine, loose texture, free of rocks, weeds and debris over 50 mm in diameter, before sod is placed (see detail sheet [COCH-LS #38](#)
- d. Lay sod with tight butt joints. Do not leave any open joints or overlap adjacent pieces of sod. Ensure that adjacent rows are laid in a staggered sequence.
- e. Big Roll Sod: Where big roll sod is to be installed, remove any and all shipping or packaging materials prior to or at the time of installation of big roll sod. Remove nylon mesh nettings or any similar materials from rolls of sod prior to or at the time of installation.
- f. Ensure finished sod surface is flush with adjoining grass areas, pavement or top surface structures such as curbs, manholes, sidewalks, irrigation boxes, etc.
- g. On slopes steeper than 3H:1V lay sod across the face of the slope and peg each row at intervals of not more than 600 mm. Secure in an approved fashion.
- h. Lay sod to a width of 3.0 m in swales and place perpendicular to direction of swale, unless otherwise noted on drawings.
- i. Immediately after installation of sod, water area with sufficient amounts to saturate sod and underlying topsoil to a minimum depth of 100 mm.
- j. After the sod and soil have dried sufficiently to prevent damage, roll the areas, if required, to ensure good bond between sod and soil and to remove minor irregularities. Clean up and remove off site all waste and extra sod at the end of each day or as directed.
- k. Protect all newly sodded areas as required.
- l. Remedy all damages, washouts and eroded areas resulting from weather, improper protection or other causes.

6.2.6 MAINTENANCE AND ACCEPTANCE

- a. Maintain sodded areas according to the Chapter 10 Landscape Maintenance Section from the time of installation until Final Acceptance Certificate is issued by The City of Chestermere Parks Department Parks Department; and
- b. Prior to acceptance, seed and water all bare spots larger than 15cm². Acceptance will be given upon establishment of sodded area.

6.3 SEEDING

6.3.1 DESCRIPTION AND QUALITY ASSURANCE

This section specifies the supply and placing of grass seed. The Contractor must have experience at performing this type and scale of work and will be required to file proof in writing of this experience prior to installation with the City of Chestermere Parks Department Parks Department.

6.3.2 PRODUCT DELIVERY, STORAGE, AND HANDLING

Deliver grass seed, fertilizer, mulch and other materials in standard containers, clearly marked with contents, weight, analysis and name of supplier or manufacturer. Ensure that the quantities of each seed species within seed mixtures are clearly marked.

6.3.3 INSPECTIONS

- a. The Contractor shall have an approved set of drawings and specifications available prior to calling The City of Chestermere Parks Department for an inspection.
- b. Make all materials, including seed, available for inspection, upon arrival on the site, or at source of supply when requested. Also verify names of suppliers when requested.
- c. Give timely notice (see 3.6 Inspections) in writing, when materials are available for inspection.
- d. Obtain the approval of The City of Chestermere Parks Department of the finished topsoil preparation before proceeding with seeding. (detail sheet [COCH-LS #38](#))
- e. Where a hydro-seeding method is used, notify The City of Chestermere Parks Department 24 hours before loading seeder and allow for an inspection at location of loading operation. Also, provide all identification labels from materials placed in hydro-seeder. Failure to notify The City of Chestermere Parks Department before loading occurs could result in rejection of the seeding operation.
- f. Installation of seed prior to inspection is the Contractor's responsibility. During an inspection, The City of Chestermere Parks Department reserves the right to reject seed if seed does not conform to specifications.
- g. Remove all rejected materials from site immediately.

6.3.4 MATERIALS

- a. *Grass Seed*: certified Canada No. 1 seed, free of disease, weed seeds or other foreign materials, meeting the requirements of the Seeds Act. All cultivars listed below must be rated in the top 25th percentile of the National Turfgrass Evaluation Plots (NTEP) located in Alberta.
The following are grass seed mixes approved by The City of Chestermere Parks Department and their appropriate application for use:
 - i. *Urban A*: for slopes up to 3H:IV, highway boulevards, interface areas and other areas where irrigation is not available; a coarse grass mixture composed of:

Kentucky Blue Grass	20%
Creeping Red Fescue	35%
Annual Rye	30%
Perennial Rye Grass	15%

- ii. *Urban B*: for play fields, joint use sites, residential boulevards and other non-irrigated but high use areas; a medium grass mixture composed of:

Kentucky Blue Grass	40%
Creeping Red Fescue	45%
Perennial Rye Grass	15%

- iii. *Urban C*: for irrigated tot lots, decorative and athletic parks; a fine grass mixture composed of:

Three (3) varieties of Kentucky Blue Grass	75%
Creeping Red Fescue	15%
Perennial Rye Grass	10%

Urban A, B, and C grass mixtures are applied at a rate of not less than 30 g/m² or 300 kg/ha.

- iv. *Urban D*: a native grass seed for reclamation of Environmental Reserves and Natural Areas where maintenance and irrigation are not available. A proposed grass seed mix that makes every attempt to use seed that is native (locally indigenous) to the Calgary region must be submitted. The mix should be based primarily on wheat grasses and will be approved on a site-specific basis. Substituting due to lack of availability of native seed must be approved in advance by The City of Chestermere Parks Department. Submissions must indicate seed suppliers for verification of source. Upon approval of the proposed grass seed mix, a seed analysis certificate shall be submitted for approval by The City of Chestermere Parks Department prior to application. Application rates to be determined on a site-specific basis;
- v. *Urban E*: a wildflower seed mixture for use as an option to Urban D in reclamation of Environmental Reserves and Natural Areas where irrigation and maintenance will not be available. It should be composed of a minimum of 10 perennial wildflower species applied at a rate of not less than 1 gm/m² or 10 kg/ha with an approved bunchgrass at 2.5 gm/m² or 25 kg/ha. A proposed wildflower mix must be submitted to The City of Chestermere Parks Department for approval;
- vi. *Urban F*: a slow growing, low maintenance mix for medium use park areas where a more natural grassland appearance is desired on a non-irrigated site; a grass mixture composed of:

Three (3) varieties of Kentucky Blue Grass	20%
Creeping Red Fescue	40%
Lowgrow Perennial Ryegrass	15%
Hard Fescue	25%

Urban F grass mixture is to be applied at a rate of not less than 20 g/m² or 200 kg/ha.

Where practical, Urban A, B, C, and F grass mixtures can be used adjacent to natural areas only if a suitable barrier can be provided (such as a pathway) to prevent the Urban mix from encroaching into the native community.

- vii. *Fertilizer*: Type and application to be determined by soil test.
 - viii. *Hydroseeding*: (as per Civil Works Transportation Alberta) Civil Works Master Specifications #02924 – Hydroseeding, 2006-10-31
- b. Mulch: Approved wood fiber mulch manufactured from whole wood chips and containing no growth or germination inhibiting factors. The following specifications shall apply:

Percent moisture content	10%
--------------------------	-----

Percent organic matter	99.2%
Percent ash content	8%
pH	4.8%
Water holding capacity	1000 gms/100 gms of fiber

Percent moisture content is determined in accordance with the Canadian Pulp and Paper Association, Technical Section, Standard A.2.

The area of coverage for a hydroseeder is based on the water carrying capacity of a mulch and the volume of water that a seeder carries. The following is the water carrying capacity for various mulches. It is quoted as the number of kilograms (kgs) of mulch necessary to hold 1000 litres of water.

Manufacturer	kg/1000 L
Fibramulch	46.84
Silva-Fiber	50.00
Verdyol Standard	37.9

The following is an example for calculating the amount of mulch necessary per hydroseeder if Fibramulch is being used:

- Hydroseeder volume is 3300 US gallons
- 3.785 is the conversion factor for US gallons to Liters
- 1000 is the water carrying capacity constant

$$\frac{\text{Hydroseeder Volume} \times 3.785}{1000} \times \text{Water Carrying Capacity}$$

$$\underline{3300 \times 3.785 \times 46.84 = 585 \text{ kg}}$$

Therefore, each hydroseed load requires 585 kg of mulch. Since Fibramulch comes in 50 lb. or 22.7 kg bags, each tank load would require 25.77 bags.

The following are the rates for the application of mulch.

Slope and/or Wind Conditions	Rate
<6:1 (H:V) Light Wind	140 kg/ha
6:1 to 3:1 Medium Wind	1700 kg/ha
>3:1 High Wind	37.9

The following is an example of calculating the area of coverage per hydroseeder load on a >3:1 slope:

- Application Rate is 2000 kg/ha (see above table)
- 10000 is the conversion factor from ha to m²
- Area covered is in m²
- Mulch per tank is 585 kg from previous calculation

$$\frac{\text{Mulch Per Tank} \times 10000}{\text{Application Rate}} = \text{Area Covered}$$

$$\frac{585 \times 10000}{2000} = 2925 \text{ m}^2$$

Therefore, the area of coverage per hydroseeder load is 2 925 m² whether it is doing seeding, fertilizing or erosion control.

- c. Tackifier: Acceptable colloidal polysaccharide tackifier, adhering to mulch during manufacturing, non-toxic and without growth or germination inhibiting factors. Apply as per labeled manufacturer's specifications for slopes 4:1 and greater.

The following are the recommended rates for the application of TA200 tackifier:

Slope and/or Wind Conditions		Rate
<6:1 (H:V)	Light Wind	50 lbs/acre
6:1 to 3:1	Medium Wind	75 lbs/acre
>3:1	High Wind	100 lbs/acre

The following is an example of converting the application rate from lbs/acre to kg/ha:

- 0.4047 is the conversion factor for acres to ha
- 0.4536 is the conversion factor for lbs to kg
- Application rate is 100 lbs/acre (see above table)

$$\frac{\text{Application Rate} \times 0.4536}{0.4047} = \text{Metric Rate}$$

$$\frac{100 \times 0.4536}{0.4047} = 112$$

Therefore, the metric application rate is 112 kg/ha.

The quantity of tackifier per tank load is calculated as follows:

- Area of coverage (as previously calculated) = 2 925 m²
- Application Rate (kg/ha) = 112
- Conversion factor from ha to m² – 10 000

$$\frac{\text{Seeder Coverage} \times \text{Application Rate}}{10000}$$

$$\frac{2925 \times 112}{10000} = 33.6$$

Therefore, 33.6 kg of tackifier is required per hydroseeder load. The following is packaging information on TA200 Tackifier:

$$1 \text{ Pail} = 50 \text{ lbs} = 22.68 \text{ kg} \sim 20 \text{ litres}$$

The following calculates the number of containers of Tackifier:

$$\frac{\text{Weight per Tank Load}}{\text{Weight per Container}} = \text{Number of Containers}$$

$$\frac{33.6}{22.68} = 1.48$$

Therefore, each hydroseeder load will have 1.48 pails of tackifier.

d. Quantities of Seed in a Hydroseeder:

The quantity of seed in a hydroseeder is calculated as follows:

$$\frac{\text{Seeder Coverage X Seed Application Rate}}{10\ 000}$$

Seed application rates are to be determined as per manufacturers' recommendations.

If the project calls for Urban F on the job site then the quantity of seed is calculated as follows:

$$\frac{2\ 925 \times 200}{10\ 000} = 58.5$$

Therefore, each hydroseeder tank load will require 58.5 kg of seed. Based on 25 kg per bag of seed, each hydroseeder load will require 2.34 bags.

e. Quantity of Fertilizer in a Hydroseeder:

Calculations to determine application fertilizer rates are to be based on soil analysis recommendations. Fertilizer rates are variable and they depend on the results of a soil analysis and the type of fertilizer applied. For this example, it is assumed that 16-20-0 fertilizer is being applied at 400 kg/ha. The result would be the following calculation:

$$\frac{\text{Seeder Coverage X Fertilizer Application Rate}}{10\ 000}$$

$$\frac{2\ 925 \times 400}{10\ 000} = 117$$

Therefore, each tank load will require 117 kg of fertilizer. Based on 20 kg per bag of fertilizer, each hydroseeder load will require 5.85 bags.

6.3.5 PREPARATION AND INSTALLATION

- a. Provide a finished topsoil surface prior to seeding that is: conducive to seed growth; even running and to finish grades; free of rocks over 25 mm in diameter; and free of weeds and debris (detail sheet [COCH-LS #38](#))
- b. Ensure that finish grade meets flush and smooth with adjacent grades and surface structures such as curbs, manholes, sidewalks, irrigation boxes, etc.
- c. On slopes exceeding 3H:1V and where hydro-seeding is the application technique to be used, track packing is an acceptable form of preparation subject to meeting conditions in items a. and b. above. The long ridges of the tread are to run across the face of the slope.

- d. Apply 91kg/ha of 16-20-0 fertilizer at the time of seeding and then, two months into the growing season apply 32kg/ha of 32-4-8 fertilizer. This rate is subject to adjustment upon receipt of the topsoil analysis report and the Contractor's recommendation as outlined in 6.1.7 Inspections and Topsoil Test.
- e. Do all seeding in accordance with good horticultural practice during the period from May 1 until September 30, or as weather permits and when wind speeds are minimal and site conditions are approved by The City of Chestermere Parks Department.
- f. Two means of applying seed are acceptable to The City of Chestermere Parks Department:
 - Hydraulically-seeding, and
 - Mechanical or "Brillion" type seedingHand broadcasting of seed is unacceptable under any conditions except for isolated repair work.
- g. Protect Hand broadcasting of seed is unacceptable under any conditions except for isolated repair work.
- h. Remedy all damaged areas and maintain until turf has properly established.

6.3.6 MAINTENANCE AND ACCEPTANCE

Maintain seeded areas according to the Chapter 10 Landscape Maintenance from the time of installation until Final Acceptance Certificate is issued by The City of Chestermere Parks Department

Prior to acceptance, top dress, seed and water all bare spots larger than 15 cm². Acceptance will be given upon germination of seeded areas.

7 PATHWAYS, TRAILS, AND PAVING STONES

7.1 PATHWAYS

The objective of the design guidelines is to produce a safe, enjoyable and universal pathway network incorporating the needs of multiple users (i.e. walkers, children's strollers, runners/joggers, people with disabilities, cyclists, in-line skaters and skateboarders), and therefore, stringent attention must be given to design details. Where location and design considerations prevent transportation and recreation functions from being accommodated together, the recreation function should be given a higher priority. The following list of guidelines is intended to assist in the development of a high-quality and fully integrated pathway system. It includes legal requirements, official policies, established standards and practices and desirable standards.

The objective of the planning guidelines is to lay out a pathway network which links together residential area parks, natural areas, public recreational facilities and other communities, cities and trail networks. .

Pathway Classification:

Regional Pathway - The regional pathway system is a city-wide linear network that facilitates non-motorized movements for recreation and transportation purposes. The regional pathway is hard-surfaced, typically asphalt and located off-street. It is a multi-use facility and no one user or type of user is to be given preference. The spine of the system parallels the major physical features of the area, including waterways, escarpments and ravines. It should be designed as a continuous facility that connects individual communities to:

- City-wide parks and recreation facilities;
- Natural features, including water courses, escarpments, and associated open space;
- Commercial districts, employment centers, adjacent communities and key regional attractions
- Local pathways, bikeways and trail systems and
- Arterial and collector roadways

Local Pathways - A local pathway is a pathway that provides secondary routes within communities, linking residential areas to facilities such as neighbourhood parks, schools and other local community designations. Local pathways may also serve as links to the regional pathway system.

7.1.1 DESIGN GUIDELINES

a. Alignments

Regional pathways shall be shown schematically in an Area Structure Plan; and have their alignment confirmed at the Outline Plan along with the local pathways. Pathways must ensure that they align and provide a continuous flow with other developments.

- i. Pathways, where desirable, should be routed along the edges of environmentally significant areas or into locations with less sensitivity in natural environment parks in order to minimize the impact on the park and reduce future damage and desire lines. Providing a lineal MR running adjacent to such sites to house the pathway would be ideal.

- b. Linear Parks
 - i. Linear parks provide open space connections within and between communities through a formal pathway network. They should accommodate a regional pathway or perform a linear recreation function for the community as a whole by providing local or regional pathway links to educational, recreational, and open space features (e.g. natural environment parks).
 - ii. Overland drainage features should be contained in linear parks only when they do not diminish the primary recreational and aesthetic function of the park, and do not occupy more than one-quarter of the park's width. Otherwise, the overland drainage feature should be contained in a Public Utility Lot or on private property.
 - iii. Utility rights-of-way should not interfere with the recreational, environmental and urban design functions of a linear park.
 - iv. Linear parks should have a minimum width of 10 m and a maximum width of 20 m.
- c. Boulevards
 - i. Avoid routing pathways along boulevards in front of residential properties.
 - ii. Avoid routing pathways along boulevards in front of driveways and cross-streets.
 - iii. For Arterial and collector roads where, residential parcels do not front onto the boulevards, provide either an asphalt multi-use pathway or parallel asphalt bicycle pathway and concrete sidewalk.
- d. Pathway Easement

Where an easement has been required for a pathway, ensure it is of an adequate width to facilitate the design and safe function of the pathway.
- e. Street Crossings
 - i. Route pathways to street intersections where possible.
 - ii. Mid-block crossings are discouraged and permitted on local streets only. If mid-block crossings occur appropriate signage is to be installed and approved through engineering plan submission.
 - iii. Avoid necessity for building mid-block pedestrian overpasses on major streets.
 - iv. Adjust subdivision layout to minimize quantity of crossings.
 - v. Line up pathway entrances to ensure visual continuity.
 - vi. Line up pathway entrances to wheel chair ramps.
- f. Play Equipment Sites
 - i. Regional pathways should not be within a minimum of 5.0 m from play area surfaces.
 - ii. Provide a minimum 2.5 m wide asphalt link from the play equipment site to a local or regional pathway.
- g. Parking Lots
 - i. Route pathways around; avoid through.
 - ii. Provide asphalt links from parking lots to pathways.
 - iii. Locate pathway entrance at street.
- h. Natural Areas
 - i. Encourage back sloping gradient to 2:1 to minimize disturbance.

- i. Pathway width:
 - 2.5 m minimum for local pathways
 - 3 m minimum for regional pathways
 - 2.5 m minimum pedestrian pathways and 2.5 m minimum bicycle pathway for twinned pathways with 3.0 m provided where possible.

At Time of Lifecycle:

- i. 3.0 m minimum for regional pathways
 - ii. 3.0 m minimum pedestrian pathways and 3.0 m minimum bicycle pathways for twinned pathways.
- a. Safety Clearance and Setback Requirements
 - i. Provide 1.0 m clear of all obstacles on both sides.
 - ii. Provide 3.0 m clear of all obstacles overhead.
 - iii. Avoid locating pathways over manholes or any utility access panels.
 - iv. Ensure 2.5 m minimum clearance from park water services.
 - v. Set back pathways a minimum of 1.0 m from face of curb
 - vi. Bollards are not acceptable, if calming measures or barriers are required, they will be approved on a case by case basis.
- b. Pathway Handrail
 - i. Pathway handrails shall be installed when a pathway is within 2.0 m of the top of a 2:1 slope or steeper, and the slope is greater than or equal to 1.0 m in depth.
 - ii. Under exceptional circumstances and subject to approval by Parks Department after an appropriate risk assessment, a safety railing may not be required. If a risk assessment is required it shall be provided by The City at no cost to the Developer.
 - iii. Minimum railing height and design to be as per detail sheet *COCH-LS #40* or to be an equivalent as approved by The City of Chestermere.
 - iv. Chain-link fence is not acceptable.
 - v. Painting
 - i. Line painting for all pathways are to follow the current version of *Calgary Parks 2019 Development Guidelines and Standard Specifications: Landscape Construction* detail sheet #36 a through h.
 - ii. Park entrances or access points curb painting is required.
- c. Pathway Junctions
 - i. Where possible, ensure pathways join at right angles.
 - ii. Provide widening of pathways with radius of 4.0 m where pathways join other pathways.
- d. Pathway Entrances/Wheel Chair Ramps
 - i. Extend pathway to street curb or sidewalk in all cases.
 - ii. Ensure pathway joins street at right angles.
 - iii. Provide a concrete wheelchair ramp (detail sheet *COCH-LS #43*), as required, where the entrance to a pathway is on a street and there is an existing concrete sidewalk.
 - iv. Provide an asphalt wheelchair ramp complete with depressed concrete curb (detail sheet *COCH-LS #44*) as required, where the entrance to a pathway is on a street and there is no existing concrete sidewalk.
 - v. When wheelchair ramps are located in sidewalks adjacent to MR, painting 3m of the concrete curb on either side of ramp to discourage parking.
 - vi. Line up entrances at crosswalks or corners.
 - vii. Line up entrances for visual continuity where pathway route crosses street.

viii. Ensure no catch basins are located at the entrance.

e. Sight-lines

Where possible, ensure no obstructions to visibility within 5.0 m of junction with other pathways and streets (trees, shrubs, utility boxes, fences, etc.).

f. Slope

i. Maximum grades:

- 8%: re-route.
- 5% to 8%: no longer than 50 m (keep bicycles and pedestrians separate and avoid curves and constrictions).
- 3% to 5%: no longer than 200 m on bicycle paths.

ii. Design Speed for cyclists – flat terrain: do not exceed 35 km/hr; downgrades: do not exceed 50km/hr.

iii. Super-elevation – on curves: 2%; maximum 5%.

iv. Stopping Sight Distances – stopping sight distance is described below:

$$\text{Maximum SSD} = v^2/[255 (f+g)] + 0.695v$$

Where: SDD = stopping sight distance

v = bicycle design speed (typically 30 km/hr)

f = coefficient of friction = 0.25

g = grade m/m (rise or descent/run)

The following table may also be used to obtain appropriate stopping sight distances.

NOTE: A stopping site distance of 35.0 m is considered a standard guideline:

Gradient	Level	Ascending		Descending	
	0.0%	2.5%	5.0%	2.5%	5.0%
SSD	35 m	33.5 m	32.5 m	36.5 m	38 m

v. Minimum Design Curve Radii – the minimum design curve radii is as follows:

$$\text{Minimum } r = v^2/[127 (e+f)]$$

Where: r = minimum radius

f = coefficient of friction = 0.25

e = super elevation

v = bicycle speed (typically 30 km/hr)

The following Table may also be used to obtain the appropriate minimum radius for asphalt pathways with two percent (2%) banking.

NOTE: A minimum design curve radii of 5.0 m is considered a standard guideline:

vi. Stairs

- Where possible, avoid use within a pathway network.
- Install bicycle ramp along one side where stairs are unavoidable.

g. Lighting

- i. Provide on local and regional pathways as required by City of Chestermere,
- ii. All lighting to be approved at design stage.

h. Pedestrian Bridges and Overpasses

- i. Railing height as per building code.
- ii. Minimum deck width 3.0 m (between railings).
- iii. Submit concept drawings to The City of Chestermere Development and Infrastructure Services for final approval. Ensure all drawings are stamped by a professional Engineer.

- iv. All pedestrian bridges will need an Alberta Transportation registration and inspection.
- i. Vehicular Bridges and Overpasses – To be approved through engineering submission.
 - i. In general, ensure sidewalks for pedestrians and widened shoulder lanes for cyclists are provided along both sides of structure.
 - ii. Where bridge is part of pathway system, ensure combined pathway and sidewalk is provided along both sides of structure.
 - iii. Railing height as per building code.
 - iv. Minimum pathway width to be 3.0 m.
 - v. Submit concept drawings to The City of Chestermere Development and Infrastructure Services for final approval. Ensure a Professional Engineer stamps all drawings. The Developer is to ensure that the proposed structure conforms to all applicable City Plans and provincial Building Code.
- j. Pedestrian Underpasses to be approved through engineering submission.
 - i. Minimum height 3.0 m and minimum width 3.0 m.
 - ii. Ensure drainage is kept in concrete swale along one side.
 - iii. Provide lighting in design submission.
 - iv. Desirable maximum length 50 m; provide break in underpass within median of divided roadways.
- k. Signage
 - i. Provide standard hazard warning signs where appropriate.
 - ii. Wayfinding signs will be provided by parks and locations determined at design stage. (see parks signage)
- l. Root Barriers

To protect pathway sections in the vicinity of aggressive rooting species, install root barrier (detail sheet *COCH-LS #47*) along sections of pathways that run through Environmental Reserves, Environmentally Significant Areas or Municipal Reserves where natural vegetation is being preserved and that have species of the Poplar family (except Aspen) or Willow family located within a 5.0 m setback of the edge of pathway. Root barrier will not necessarily run continuously through the Environmental Reserves, Environmentally Significant Areas or Municipal Reserves. They will only be installed where there are encroaching species as per detail sheet *COCH-LS #48*. Vertical root barrier may be required and location will be shown on approved landscape designs. Specifications for vertical root barriers can be approved through manufacturers specifications.
- m. Amenities
 - i. In general, provide one trail entrance every 150 m or as needed.
 - ii. One park bench every 250 m; one picnic table every 500 m. Environmentally sensitive areas should be assessed on a site by site basis.
- n. Accessible Use
 - i. Primarily includes people in wheelchairs or without sight.
 - ii. The needs of these users are more stringent than for other walkers.
 - iii. To fully accommodate all users in trail design.

7.1.2 STANDARD SPECIFICATIONS

a. Description and Quality Assurance

This section specifies the construction of functional and cost-effective pathways. The Contractor must have experience at performing this type and scale of work and be willing to provide proof of this experience.

- b. Inspections
 - i. The Contractor shall have an approved set of drawings and specifications available prior to calling The City of Chestermere Parks Department for an inspection.
 - ii. The Contractor shall obtain approval for the pathway alignment and sub-base (i.e. compaction and depth of gravel) prior to surfacing with asphalt.
 - i. All pathways shall be inspected by The City of Chestermere Parks Department.

7.1.3 SURFACE MATERIALS

- a. Materials
 - i. Sub-base: 25 mm crushed gravel.
 - ii. Surface: Mix “B-50” asphaltic concrete.
 - iii. Root Barriers: 40 mil.* thickness (high-density polyethylene) product or approved equal (detail sheets *COCH-LS #47-48*). *NOTE: * mil. Unit of measurement used for plastic thickness; 40 mil. = 1 mm.*
- b. Installation
 - i. Compact subgrade to 98% S.P.D.
 - ii. Compact sub-base to 98% S.P.D. The sub-base shall be 100 mm thick of 25 mm crushed gravel.
 - iii. Surface with 75 mm thick asphalt to ensure:
 - Density values shall be established by Marshall Method – 50 blows with mechanical compaction. Minimum density of 96% of its maximum design density. Densities less than 96% shall be paid for as shown in The City of Calgary Roads Construction Specifications item 308.05.02.
 - Central crown with 2% cross fall except where super elevation required on a curve; and
 - No trapped low areas on pathway surface.
 - iv. Ensure pathways are not used as drainage swales. Use swales and culverts (detail sheet *COCH-LS #50*) to ensure there is positive drainage away from the pathway surface. Culverts are to be sized according to adequately handle the anticipated flow.
 - v. Place good quality (raked and rolled) topsoil and sod, unless otherwise specified, on turf areas damaged by construction.
 - vi. Ensure that the sod surface is flush with the pathway edge.
- c. Maintenance

Maintain pathways according to the Chapter 10 Landscape Maintenance from the time of installation until Final Acceptance Certificate is issued by The City of Chestermere Parks Department

7.2 TRAILS

Trails are constructed linear paths with a granular surface generally located in natural areas and as secondary routes. As a management tool they identify intended public routing and can formalize desire lines to minimize impact on the natural environment.

7.2.1 PLANNING GUIDELINES

- a. Alignments
 - i. Use trails to give low impact and low-cost pedestrian access to parks, natural areas and sensitive or steep areas where pathways are not appropriate.

- ii. Use trails as a secondary system to pathways.
- iii. Ensure trail alignments correspond to Master Area Structure Plans, Area Structure Plans, Outline Plans and other Council-approved policy documents.

7.2.2 DESIGN GUIDELINES

The objective of these design guidelines is to produce safe, universal and enjoyable trails incorporating the needs of pedestrians, skiers and the disabled where possible, while respecting the surrounding environment.

All design guidelines are the same as regional and local pathways with the exceptions of:

- o. Natural Areas
 - i. Align trails around significant areas and sites; never through.
 - ii. Avoid damage to natural features, vegetation and wildlife habitat.
 - iii. Increase back sloping gradient to 2:1 to minimize fill coverage.
- p. Surface Materials
 - i. Trail mix, rundle chip (black), or crushed gravel (crusher fines) for formal, designed trails.
- q. Width
 - i. 1 m for informal trails.
 - ii. 2.5m for formal designed trails.
- r. Stairs
 - i. Avoid the use of stairs where possible.
 - ii. 1.0 m to 2.0 m wide; of wood or rock; handrails as required for safety.

7.2.3 STANDARD SPECIFICATIONS

All standard specifications are the same as regional and local pathways with the exceptions of:

- a. Materials
 - i. Granular trail mix, black rundle, or crushed gravel depending on use and as approved by The City of Chestermere Parks Department.
 - ii. Parks Gravel Trail Mix

This product has been customized for pedestrian and bicycle oriented trails; it is not suitable for extensive vehicle use. Moisture content and timely compaction are important when placing this material.

Description:	Gravelly sand, some silt, trace of clay	
Optimum Moisture Content:	7.5%	
Grain Size Distribution:	Gravel	- 21.8%
	Sand	- 61.5%
	Silt	- 12.8%
	Clay	- 3.9%

The combined aggregates meet the following gradation:

Sieve Size (mm)	Percentage Passing
16.000	100
12.500	98 – 100
10.000	80 – 98
5.000	55 – 80
2.500	40 – 60
1.250	35 – 50
0.630	28 – 43
0.315	23 – 36
0.160	15 – 25
0.800	8 - 18

Gravel Trail Mix:

The gravel trail mix must be laid upon a dry firm sub-grade, true to grade and cross-section, and free from all screening or other loose or foreign material. No gravel trail mix will be installed when the sub-grade is wet or when other conditions prevent proper spreading, finishing or compaction of the gravel trail mix.

Trail mix stockpiles stored on site greater than 30 days will be subject to inspection to ensure mix has retained correct properties (i.e. proportion of fine materials). After 30 days, contractor may be required to re-mix trail mix to ensure correct distribution of materials. All supply and installation of granular trails shall be as per The City of Calgary Roads Construction Specifications, Section 303.04.00; 305.00.00; Standard Drawings 454.1011.002 (Sheet 19), 454.011.003 (Sheet 16), and 454.1011.004 (Sheet 18). Adherence to the desired mix will enhance life of the product reducing materials from being washed away, broken down and/or the creation of potholes.

- iii. Asphalt or other alternatives only in cases of heavy usage or extreme erosion problems.
- b. Installation
 - i. Strip existing surface material to allow for a 150 mm compacted depth of approved material (see “Materials” section “c” above).
 - ii. Haul and place trail mix to allow for crowning and compaction. Material to be placed and compacted on the same day.
 - iii. Top of compacted trail mix should be 25 mm higher than adjacent vegetation and existing conditions.
 - iv. Provide 3 - 5% cross-fall or central crown as determined by site conditions. Final surface to be level and true with minimal undulations. Ensure that there are no trapped low areas on the trail surface. Provide positive drainage away from the surface with diagonal water bars, ditches, swales and culverts.
 - v. Finished trail compacted to 95% maximum dry density. Multiple passes by a vibrating roller with the application of water may be required to achieve the specified level of compaction. Ensure no loose fine materials are left on the surface.
 - vi. The finished gravel trail surface will be at the same elevation as any connecting existing trails or pathways. All grading will be free draining and is not to impede existing drainage.
 - vii. Place topsoil (raked and rolled) and grass seed mix, as approved by The City of Chestermere Parks Department, on areas damaged by construction.

c. Maintenance

Maintain trails according to the Chapter 10 Landscape Maintenance from the time of installation until Final Acceptance Certificate is issued by The City of Chestermere Parks Department

7.3 CONCRETE PAVING STONES

7.3.1 DESCRIPTION/QUALITY ASSURANCE

This Specification shall indicate the manufacturer, delivering, and placing of concrete pavers of various types. The Contractor must have experience at performing this type and scale of work and must be willing to provide proof of this experience.

7.3.2 MATERIALS

- a. Cement: Shall be Portland Cement conforming to the requirements of CAN3-A5-M77.
- b. Aggregates: Shall conform to the requirements of CAB3-A23-M77.
- c. Admixtures: Shall conform to the requirements of CAN-A23.1-M77.
- d. Concrete Compressive Strength: Prior to delivery to site
 - Average Strength 55 MPa
 - Minimum Strength 50 MPa
- e. Absorption: Maximum individual sample 5% ASTM C140.
- f. Resistance to Freezing and Thawing: The manufacturer shall satisfy the purchaser either by proven field performance or a laboratory freezing-and-thawing test that the paving units have adequate resistance to freezing and thawing. If a laboratory test is used, when tested in accordance with Section 8 of Method C67, specimens shall have no breakage and not greater than one percent (1%) loss in dry weight, of any individual unit when subjected to 50 cycles of freezing and thawing. This test shall be conducted not more than 12 months prior to delivery.
- g. Abrasion Resistance: When tested in accordance with Method C418, specimens shall not have a greater volume loss than 15 cm³ per 50 cm². The average thickness loss shall not exceed 3 mm.
- h. Mix Design and Concrete Testing: The supplier shall, immediately after award of Tender and prior to any casting of interlocking stone, submit to The City of Chestermere Parks Department for approval, the proposed mix design including source of proposed aggregates.

The supplier shall notify The City of Chestermere Parks Department of casting items in order that arrangements for concrete testing and/or inspection can be made as desired, at the expense of The City. The supplier shall allow the Engineer free access to those portions of his plant where the pavers are being produced and stored, for this purpose.

7.3.3 WORKMANSHIP AND PROCEDURES

- a. Forms: Shall be true to shape, lines and dimension called for on the drawings. They shall be substantial and tight to prevent leakage of moisture. Maximum tolerance for final dimensions shall be ± 2 mm.
- b. Concrete Compaction: During casting, sufficient vibratory or other mechanical effort shall be applied to thoroughly compact the concrete.
- c. Moist Curing: The surfaces of fresh concrete shall be kept continuously moist for a period of at least seven days and shall be protected against the harmful effects of sunshine, drying winds, cold running water, surface water, and mechanical shock. The temperature of the concrete shall be kept at 20° Celsius for not less than seven days.
- d. Steam Curing: If steam curing is used to maintain a daily cycle of casting, the following criteria for curing shall be adhered to:
 - i. There shall be a minimum of four hours delay after final placing of the concrete prior to the application of steam.
 - ii. The maximum rate of temperature rise of the concrete shall be 20° Celsius per hour.
 - iii. The maximum temperature to which the concrete shall be raised shall be 70° Celsius.
 - iv. The maximum rate of cooling shall be 20° Celsius per hour.

Immediately after stripping of forms, the members shall be moist or steam cured for an additional five days at a temperature of not less than 65° Celsius.

- e. Handling, Storage and Delivery: Care shall be taken in the handling, storage and delivery of completed interlocking stone to avoid damage. Damage to units prior to acceptance by The City at the point of delivery shall be rectified by the supplier at no extra cost to The City.
- f. The concrete pavers shall be delivered to the site of work as directed by The City of Chestermere Parks Department, and shall be unloaded and stacked at a specified location.
- g. Visual Inspection: All units shall be sound and free of defects that would interfere with the proper placing of the unit or impair the strength or permanence of the construction. Minor cracks incidental to the usual methods of manufacture or minor chipping resulting from customary methods of handling in shipment and delivery shall not be deemed grounds for rejection.
- h. Sampling and Testing: The purchaser, or his authorized representative, shall be accorded the proper facilities to inspect and sample the units at the place of manufacture from lots ready for delivery. Sample and test units in accordance with method C140.
- i. Rejection: In case the shipment fails to conform to the specified requirements, the manufacturer may sort it, and new specimens shall be selected by the purchaser from the retained lot and tested at the expense of the manufacturer. In case the second set of specimens fails to conform to the test requirements, the entire lot shall be rejected.

7.3.4 THE BASE (DETAIL SHEET COCH-LS #53)

Sieve Size (mm)	Percentage Passing
9.50	100
4.75	95 – 100
2.36	80 – 100
1.18	50 – 85
600µm	25 – 60
300µm	10 – 30
150µm	2 – 10

This sand plus six percent (6%) Bentonite shall be used for surface leveling and crack filling.

7.3.5 SAND BEDDING COURSE (DETAIL SHEET COCH-LS #53)

- a. The sand-bedding course shall be spread evenly over the area to a level that will produce the required 50 mm thickness when the paving stones have been placed and vibrated.
- b. Once leveled, this sand-bedding course shall not be disturbed in any way.

7.3.6 INSTALLATION (DETAIL SHEET COCH-LS #53)

- a. Where service vehicles will be traveling on concrete paving stones, the pavers shall be set on a concrete base. The pavers shall be seated on latex or polymer modified mortar. All joints shall be mortar filled.
- b. Where service vehicles will not be traveling on concrete paving stones, a subgrade and gravel base each compacted to 95% S.P.D. will be acceptable.
- c. Edge Restraint: All edges of the patio installation shall be restrained. There shall be positive edge restraint and the type of restraint used shall be subject to the approval of The City of Chestermere Parks Department.
- d. Laying of Concrete Pavers:

- i. The concrete pavers shall be laid in a pattern approved by The City of Chestermere Parks Department.
- ii. The concrete pavers shall be laid in such a manner that the desired pattern can be maintained and the joints between the stones do not exceed 3 mm.
- iii. The gaps at the edge of the paved surface shall be filled with standard edge pieces or with stones cut to fit. The stones shall be cut to a straight even surface without cracks or chips.
- iv. The concrete pavers shall be vibrated to their final level.
- v. After vibration, sand shall be brushed over the surface and vibrated to completely fill the joints. Sands worked between the paving stones shall be thoroughly mixed with six percent (6%) by weight of bentonite clay.
- vi. Surplus material shall then be swept from the surface and the entire site left clean.
- vii. After final vibrating, the surface shall be true to line and grade and shall not vary by more than 8 mm when tested with a 3.0 m board at any location on the surface.

7.3.7 MAINTENANCE

Maintain concrete paving stones from the time of installation until Final Acceptance Certificate is issued by The City of Chestermere Parks Department

7.4 PERMEABLE PAVERS

In the management of stormwater, the City is encouraging the use of alternative methods from the current construction standards in that permeable surfaces are created to absorb storm runoff to mitigate damages from flooding.

7.4.1 DESCRIPTION/QUALITY ASSURANCE

This Specification shall indicate the manufacturer, delivering, and placing of concrete pavers of various types. The Contractor must have experience at performing this type and scale of work and must be willing to provide proof of this experience.

7.4.2 MATERIALS

When researching possible permeable surface products, we would recommend that you look towards an alternative that includes grass. Any permeable surface that you are considering installing must allow for the percolation of stormwater and prevent direct runoff in the form of sheeting. Alternative materials will be reviewed prior to acceptance by the City's Parks Department Parks Department.

At the preliminary drawing phase of application to development landscape drawings submitted for review shall include:

- a. The product name/brand; and
- b. A brochure/pamphlet detailing the product specifications, installation, and maintenance requirements of the product to be installed.

7.4.3 MAINTENANCE

Maintain permeable paving stones from the time of installation until Final Acceptance Certificate is issued by The City of Chestermere Parks Department

8 AMENITIES

8.1 DEVELOPMENT GUIDELINE

The new Land Use Plan 022-10 provides requirements for a Development Permit (DP). Under this Plan certain amenity structures may require a Development Permit (DP) prior to construction. The Alberta Building Code as provincial legislation also requires the approval of a Building Permit (BP) for certain works. It is the Developer's responsibility to ensure that the proposed development complies with all applicable City Plans and provincial Building Codes. Development and Infrastructure Services and Parks Department approval of the landscape construction drawings does not supersede this requirement.

8.2 MATERIAL AND INSTALLATION STANDARDS

The following list is a list of all standards and regulations referred to within the Amenities Section of this manual.

All standard specifications are the latest issue, except when a year is mentioned (Please check official websites to ensure you are utilizing the current guidelines and/or specifications).

A.S.T.M. (<http://www.astm.org/>)

A-36-81a		Specification for structural steel
A-325-71a		Specification for high strength bolts for structural steel
D-693-70		Test for moisture-density relations of soils and soil aggregate mixtures.

C.S.A. (<http://www.csa.ca/cm/ca/en/home>)

0121-	M1978	Douglas Fir plywood
0141-	1970	Softwood lumber
0151-	M1978	Canadian softwood plywood
G40.21-	1976 & 2	Structural quality steels supplements
Can 3-G4021	MB1	Structural quality steels
G164-	M1981	Hot dip galvanizing for irregularly shaped articles
W47.1-		1983 Certification of companies for fusion welding of steel structures
W59-	M1984	Welded steel construction (metal arc welding)

C.G.S.B. (http://isbndb.com/d/publisher/canadian_government_publications_a02.html)

NOTE: The preceding standards can be obtained from the following:

A.S.T.M.	American Society for Testing and Materials 1916 Race St. Philadelphia, Pennsylvania 19103 http://www.astm.org/
C.S.A.	Canadian Standards Association 5060 Spectrum Way, Suite 100, Mississauga, ON L4W 5N6 1-800-463-6727 www.csa.ca

8.3 PLAY STRUCTURES

8.3.1 DESIGN GUIDELINES

All playgrounds must follow inclusive play and allow minimum of 25% of the playground to be considered appropriate for universal use Rick Hansen Foundation A Guide to Creating Accessible Play Spaces for recommendations.

8.3.2 DESCRIPTION AND QUALITY ASSURANCE

This section specifies the supply and installation of Play Structures. The Contractor must have experience in performing this type and scale of work and must be willing to provide proof of their experience.

8.3.3 INSPECTIONS

- a. The Contractor shall have an approved set of drawings and specifications available prior to calling The City of Chestermere Parks Department for an inspection.
- b. The design and installation of playground structures must comply with C.S.A. guidelines on children's play spaces and equipment.

NOTE: A letter of compliance to C.S.A. guidelines will be required prior to signing a construction completion *certificate*

Canadian Standards Association
5060 Spectrum Way Suite 100 Mississauga, ON L4W 5N6
1-800-463-6727 www.csa.ca

- c. Give timely notice (see 3.6 Inspections) to The City of Chestermere Parks Department when Construction Completion Certificate for work is required.

8.3.4 MATERIALS

All materials will be approved based on CSA standards. Provide engineered mulch or rubber surfacing following the CSA guidelines for fall surfacing requirements.

8.3.5 EQUIPMENT DESIGN AND LAYOUT

- a. Hardware:
 - i. All suspended elements, such as trapeze bars, rings, tight rope cables and swing seats, shall be fastened at top and bottom by means of a positive locking system such as hammer locks or clevis hooks (no quick links). These hooks should have lock tight attachments to prevent removal by equipment user.
 - ii. All chains shall be at least 1/4" or larger, zinc plated or galvanized.
 - iii. Swing Seats and chains shall be connected by means of a positive locking system such as hammer locks or clevis hooks (no quick links).
 - iv. Eye bolts must be forged or welded.
 - v. Bearing hangers shall be complete with oil impregnated bronze bushing and shall be wrap-free in design.
- b. Slides:
 - i. The sitting section of all slides shall have protective side enclosures that diminish from guardrail height (i.e. 600 mm) to side wall height (i.e. 100 mm) in a smooth curve. They shall be designed so that the user's flow of hand movement is unhampered and smooth.
 - ii. All sliding surfaces shall have sidewalls to control and guide descent and prevent the lateral discharge of the child during descent. A minimum height of 100 mm of sidewall shall be provided and may be reduced to zero at the exiting section.
 - iii. All slides shall be oriented north or east (i.e. not south or west).
 - iv. Plastics used in the construction of slides will be at the discretion of Parks Department. Slides that are constructed out of metals must not be subject to structural degradation such as rust or corrosion.
- c. Tube Structures: Tube structures and any other apparatus that restricts visibility into the structure will not be permitted.

- d. Swings: The distance between individual swings and the distance between a swing and the swing structure shall be at least 750 mm (30 in.).
- e. Posts:
 - i. All support post shall be a minimum of 3" square 11 – gauge galvanized tubing, or 3.5" round 11 – gauge galvanized tubing c/w polyester powder coat finish. For structures designed for 5-12-year-old children, there is a preference for posts of at least 5" diameter or 5" square.
 - ii. Post caps shall be secured by means of electronic weld, rivets or interference fit rib.
 - iii. A settlement block, such as 2X6 pressure treated spf, larger than the footprint of the post must be placed at the bottom of the hole prior to installation of posts.
- f. Teeter Totters: Teeter totters shall not have inclines more than 25° from the ground and the teeter totter beam shall be of such a length that children are no more than 1.524 m (5 feet) from the ground.
- g. Bridges: Suspended bridges must have positive locking system such as hammer locks.
- h. Concrete Anchors: All concrete anchors shall be installed at a minimum depth of 300 mm below the surface of the play area.
- i. Coatings: All metal surfaces must be galvanized, plated, stainless steel, baked on paint etc. to resist corrosion. All paint must be lead free and conform to industry standard.
- j. Benches: Subject to providing a universally accessible surface for access, benches may be installed inside the children's play space border. All related CSA Guidelines must be adhered to.

8.3.6 INSTALLATION

- a. In parks where play equipment is an appropriate development activity and a play structure is not to be installed by the Developer, a level turf area of 25 m² must be made available by the Developer for future installation. Ensure that the future location is clearly labeled on the Layout Plan.
- b. Prior to installation, the Contractor shall submit to The City of Chestermere Parks Department for approval the construction plans as well as the product name and model type or number of the play structure.
- c. Ensure that the base of the play area is constructed to provide adequate surface drainage.

8.3.7 MAINTENANCE

Maintain play structures according to the Chapter 10 Landscape Maintenance from the time of installation until Final Acceptance Certificate is issued by The City of Chestermere Parks Departments.

Playground inspections must take place monthly and reports submitted at FAC. If monthly inspections are not completed or reported an annual audit will be required from time of compliance and within 3 months of FAC.

8.4 SITE FURNISHINGS AND AMENITIES

8.4.1 DESCRIPTION AND QUALITY ASSURANCE

This section specifies the supply and installation of site furnishings. The Contractor must have experience in performing this type and scale of work and must be willing to provide proof of this experience.

8.4.2 INSPECTIONS

Give timely notice (see 3.6 Inspections) to The City of Chestermere Parks Department when Construction Completion Certificate for work is required. Requirements for amenity and furniture inspections vary, specific directions for inspections details will be discussed at the start up inspection of each site.

8.4.3 DESIGN APPROVAL

- a. Submit drawings for The City of Chestermere Parks Department' review on items as noted.
- b. Clearly show materials, connections, attachments, reinforcements, anchorage and location.
- a. General Guidelines:
 - i. All site furnishings design and specifications must be reviewed and approved by The City of Chestermere Parks Department prior to installation as part of the landscape plan submission.
 - ii. All site furnishings should be of a consistent style and type within the community and or development phase.
 - iii. All furniture must be fully installed to receive final CCC approval.
 - iv. Larger amenities may require a manufactures maintenance kit at FAC.
- b. Trash Receptacles:
 - i. Design - Haul-all containers or equivalent are mandatory, additional receptacles can be installed at the discretion of The City of Chestermere Parks Department.
 - ii. Installation
 - Preferred location to be installed by pathways and not benches or gathering locations.
 - Provide removable concrete pads from bin supplier.
 - Provide one bin at each entrance of the park, additional locations will be approved at the discretion of the parks department.
- c. Bench:
 - i. Design – Provide manufacturers details including materials and specified paint colours for maintenance and lifecycle. Bench locations will be reviewed on a case by case basis following the minimum and maximum landscape guideline activities tables 3 -6.
 - ii. Installation
 - Seating surface to be 410-440 mm above finished grade.
 - Pedestals must be set in concrete to a minimum depth of 600 mm below finished grade and provide a concrete, asphalt or paver pad directly surrounding the bench.
 - Ground model types must be bolted to a concrete pad using vandal resistant fasteners as per the manufacturer's requirements.

8.5 PARKS SIGNAGE

Interpretive, community information / bulletin boards, educational and other proposed signs are welcomed and approved during the detailed landscape design stage through the City of Chestermere Parks, Recreation and Communication departments. Standard park signs, such as tot lot signs, wayfinding or Storm pond signs will be determined at the detailed landscape design stage. The Parks department will provide the sign during the construction to the consultant. The developer is responsible for the mounting and installation the signs as part of the CCC process. Any marketing signs must be approved through Planning.

8.6 FENCING

8.6.1 MATERIALS (CHAIN LINK)

Refer to The City of Calgary Roads Construction Specifications.

8.6.2 DESIGN

- a. Location and Type
- a. Fencing Adjacent to Open Space: School, Park sites and other park sites are to be separated from private development by permanent fencing. Fences including the concrete pile must be constructed wholly within private property. Fencing is to be a minimum 1.2m height and suitable for restraining pets.
- b. Fencing Adjacent to parkland with formalized sports fields or future sports fields shall be a minimum 1.8m height and protect against stray balls. Since sports fields on site may be realigned in the future, any private properties adjacent to a site with potential future sports fields shall be separated using minimum 1.8m height fencing. Contact a Planner/Parks or landscape Architect/Parks pertaining to the site program.
- c. Where parks and utility lots/ROWs abut lanes and there is not standard curb installed: Post and cable fencing is to be installed in the asphalt.
- d. Environmental Reserves, Natural Areas and existing trees: Area to be fenced off with construction fence or equivalent by the Developer prior to construction. The Developer will contact the Parks Department for a meeting to verify the location of this temporary fencing prior to installation.

8.6.3 INSTALLATION (POST AND CABLE) (DETAIL SHEET COCH-LS 63)

- a. Provide all new material unless directed otherwise.
- b. Post spacing to be as detailed or as specified by City of Chestermere Parks Department.
- c. Orient the face cuts of the posts as directed by the Parks Department on a site-specific basis.
- d. Provide sufficient tension on steel cable to eliminate sag.
- e. Install the first cable clamp over-top the end of the cable to eliminate frayed ends.

8.7 LIGHTING

Lighting may be permitted on park land provided:

- a. In accordance with LUB, Design Guidelines, Recreation Master Plan and other City of Chestermere policies.
- b. It is identified by The City as part of the transportation system; or
- c. It is used as security for structures (CPTED); or
- d. Lighting of parks will be at the discretion of Parks Department at the time of design review.
- e. Lighting may require an Optional Amenity Agreement.
 - a. Shall be 6 Lux minimum (Fortis light summary sheet).
 - b. LED Street Lighting will be required.
 - c. "Dark sky" lighting will be required.
 - d. Solar Lighting may be encouraged.
 - e. Timing systems must be available on all fixtures.

8.8 OPTIONAL AMENITIES

- a. Optional amenities are non-standard infrastructure development (i.e. ornamental fencing, water

features, gazebos, sculptures, entrance features/signs, decorative fixtures, etc.) in a public park or road ROWs(MR, MSR, PUL,ER, ROW's).

- b. Under the Municipal Government Act, Community Entrance Features that contain the name, logo, address of the community, or the Developer's identification, cannot be placed on Municipal Reserves. Community Entrance Features with this type of information must be placed on private lands or within wider road ROWs upon approval of The City of Chestermere Parks Department
- c. If Community Entrance Features are placed on road ROWs, an Optional Amenities Agreement is required.
- d. If a Developer or homeowners'/residents/community association wishes to construct an optional amenity within a public park or a road ROW, they must receive approval from The City of Chestermere Parks Department.
- e. The intent to construct optional amenities must be identified in the landscape concepts provided for the Outline Plan (OP) or if the OP is already approved, at the Landscape Plan approval via letter of intent or other suitable mechanism.(i,e noted on the design). The development agreement will include the optional amenities details including the determined fees.
- f. Fees will be calculated by using the cost of removal of the amenity and replacement of turf or other approved landscaping by averaging three estimates provided by the applicant.
- g. If the OAA is not already included in the development agreement, a Developer or homeowners'/residents/community association wishes to construct an optional amenity, they must either enter into an Optional Amenities Agreement (OAA) and/or a Landscape Maintenance Agreement with The City, such agreement shall be signed prior to construction approval.
- h. Maintenance manuals are to be submitted to The City prior to receiving a final CCC for all optional amenities associated.
- i. Payments received prior to receiving FAC of amenity and adjacent lands.

8.9 LANDSCAPE BOULDERS AND ROCKS

- a. Landscape boulders/rocks must be placed in planting beds and/or tied-in to the landscape. All other landscape Boulders/Rocks must be place in planting beds.
- b. Landscape boulders/rocks near playgrounds must meet the safety setbacks as specified in the CSA guidelines.
- c. Armouring banks with natural stone will be encouraged, except the use of sandstone.

NOTE: Landscape boulders and rocks are not allowed within a playground area.

8.10 PEDESTRIAN BRIDGES

- a. Submit drawings as part of the landscape plan package to The City of Chestermere Parks Department. Ensure a Professional Engineer stamps all bridge drawings.
- b. The bridge must have a minimum weight requirement of 3000kg and minimum 3m wide for maintenance equipment.
- c. The Developer is to ensure that the proposed structure conforms to all applicable City Plans and provincial Building Codes.
- d. Prior to CCC the bridge must be inspected by Alberta Transportation and receive registration identification.

8.11 RETAINING WALLS

Submit concept drawings for approval to City of Chestermere Parks Department. If the retaining wall is

to be made from sandstone, it shall be constructed as per detail sheet *TOS-LS #54*. Sandstone is NOT encouraged for walls partially, wholly or temporarily submerged in water. Ensure a Professional Engineer stamps all drawings of retaining walls that exceed 1.0 m in height. The Developer is to ensure that the proposed structure retaining wall conforms to all applicable City Plans and provincial Building Codes.

8.12 MAINTENANCE

Maintain site furnishings and all amenities in accordance with Chapter 10 Landscape Maintenance from the time of installation until Final Acceptance Certificate is issued by The City of Chestermere Parks Department

9 IRRIGATION

9.1 DESCRIPTION AND QUALITY ASSURANCE

- a. This section specifies the supply and installation of irrigation systems. Installers must have experience at this type and scale of work and be willing to provide proof of experience.
- b. Contractors working on irrigation systems and supplemental components that will eventually be turned over to The City shall be certified as a Certified Irrigation Contractor (CIC). The contractor must ensure the project superintendent, or authorized designate, responsible for the daily delivery of the project be certified as a CIC.”

9.2 DESIGN

- a. The Contractor shall have an approved set of drawings and specifications available prior to calling The City of Chestermere Parks Department for an inspection. Irrigation plans should be submitted as part of the landscaping approval package. All installations require inspections and acceptance from The City.
- b. Irrigation systems will be approved as one system in each landscape submission. Irrigation systems cannot be extended into other phases, another water source and controller must be installed or FAC will not be approved until final phase of the entire system is completed.
- c. Storm pond irrigation systems or any non-potable water sources will be considered and required to follow engineering standards. For Parks irrigation infrastructure the Minimum requirements are:
 - i. All delivery components and valves shall have non-potable indicators such as purple covers or purple handles.
 - ii. Water quality tests at CCC / FAC.
 - iii. Storm water irrigation for sport fields or line assignments will be evaluated and approved on a case by case basis.
- d. High Density Polyethylene (HDPE) is accepted when following the current version of *Calgary Parks Development Guidelines and Standard Specifications: Landscape Construction*.

9.3 PRODUCT DELIVERY, HANDLING, AND STORAGE

- a. Store all materials off the ground and under protection until ready to use. Support as required to prevent excessive strain on piping.
- b. Remove off site all material that is damaged or rejected. No material that has been damaged shall be installed. The City of Chestermere Parks Department reserves the right to reject any material that does not meet specifications.

9.4 JOB CONDITIONS

- a. Proceed with irrigation installation only during suitable weather conditions.
- b. Report to The City of Chestermere Parks Department, prior to commencing work, of any conditions or defects encountered on the site upon which work of this section may depend and which may adversely affect the performance of the work.
- c. Do not commence work until such conditions or defects have been investigated and corrected.
- d. Protect the system from being contaminated during construction by blocking all open pipe ends.

9.5 INSPECTIONS AND TESTINGS

9.5.1 OPEN TRENCH INSPECTIONS AND TESTING

- a. The City of Chestermere Parks Department shall be given a minimum of 24 hours notice when an open trench inspection is required.
- b. Items which must be in place and complete for the open trench inspection include:
 - i. Trench depth and alignment.
 - ii. Bedding material.
 - iii. Pipe alignment joints and expansion couplers, valves.
 - iv. Drains with gravel sumps.
 - v. Swing joints and head locations.
 - vi. Thrust blocking and conduit under paving.
 - vii. Pressure test without heads (static water pressure).
 - viii. Electrical wiring and electrical conduit
 - ix. Meter as supplied by The City of Chestermere Parks Department.
 - x. Other items.
- c. Items b. (iii) through (viii) above shall be inspected in the event that the system is "plowed-in."
- d. Receive in writing from The City of Chestermere Parks Department acceptance and approval of the irrigation system as viewed during the open trench inspection before back filling.

9.5.2 CONSTRUCTION COMPLETION INSPECTION AND PRESSURE TEST

- a. The City of Chestermere Parks Department shall be given a minimum of 24 hours notice when a construction completion inspection and pressure test is required.
- b. The inspection and pressure test shall not be done unless written proof of the open trench inspection is available.
- c. Items which must be in place and complete for the inspection and pressure test include:
 - i. Back filling and landscaping.
 - ii. Drain and valve boxes installed as per specifications and clear of debris.
 - iii. Water pressure on and flowing freely through the system.
 - iv. Irrigation head adjustment and all heads activated and throwing water to provide adequate coverage as per manufacturer's recommendations and the plan.
 - v. At the City of Chestermere Parks Department discretion, a pressure gauge shall be placed on any point in the system and a reading shall be taken to confirm operating pressure in system. Pressure gauges shall be minimum 50 mm face, 0-1000 kPa, Peacock or equal, complete with pet cock.
 - vi. Annually test the backflow prevention device; a copy of the Testing and Inspection Report for Double Check Valve Assemblies shall be submitted to Parks Department. The municipal address of the site shall be indicated on the Testing and Inspection Report.
 - vii. Submit a completed Parks Meter Record form.
 - viii. Supply a copy of the Plumbing Permit.
 - ix. Submit two paper copies of preliminary as-built drawings for verification. These drawings will state the municipal address of the site. As-built drawings received at CCC will be verified by

Parks Department prior to FAC. Discrepancies, if any, are to be noted and corrected on the as-built drawings.

- i. Receive in writing from The City of Chestermere Parks Department acceptance and approval of the construction completion inspection and pressure test.
- ii. The Developer must submit digital drawings showing the exact "as-built" location of the irrigation system prior to the issuance of a CCC

9.5.3 AS-BUILT DRAWINGS (DETAIL SHEET TOS-LS 64)

- a. Verify all conditions on the site and immediately report all discrepancies and variations from the drawings to The City of Chestermere Parks Department.
- b. Submit digital drawings (dwg and pdf formats) which has been drafted in a professional manner and is to scale on legal base plan, which shows the exact "as-built" location of the system relative to property line, including the locations of all lines, sprinkler heads, valves (drain and zone control), boxes, double check valves, parks water service, curb stops, underground pipe fitting not adjacent to surface fixtures (tee, elbows, etc.) saddles for poly pigtailed and other irrigation materials prior to the issuance of a Final Acceptance Certificate. All of the above items must be tied in at two points each from site property lines or other permanent on-site features
- c. Requirements for acceptable submission of 'as-built' drawings will include, but not be limited to, the following:
 - i. Sheet size to be 594 mm x 841 mm (approx. 22" x 34") (Sheet Size A1).
 - ii. Labeled as "As-built Irrigation System".
 - iii. Key plan showing location of site, including street names.
 - iv. Labeling to be a minimum of a 12-pt. font.
 - v. Plan of site showing property lines, bearings, surrounding site uses, north location, on-site structures, utilities, fences, buildings, walkways, etc., all to a suitable metric scale.
 - vi. List Sources i.e. surveyor, base map, topography.
 - vii. Municipal address and legal description of said property including a registered plan number. If more than one address, refer to location of parks water service.
 - viii. Largest scale (1:250) with a minimum letter size of 12 pt. font.
 - ix. Legend: Do not include Detail Sheets in as-built drawings. Instead, refer to the year of specification and the Detail Sheet name and number (i.e. 1998, Drain Pit for PVC Pipe, detail sheet *TOS-LS #110*). Clarify type of irrigation system (gravity drain, blow out or main line gravity drain with lateral line that has to be blown out).
 - x. Number all irrigation zones starting from DCVA and turning to the right at a mainline junction. Return to last turn and continue as before until all zones are numbered.
 - xi. Name, address and 24-hour phone number of installer as well as owner/Developer and Consultant, where applicable.
 - xii. All 110-volt electrical wire and 110-volt electrical conduit.
 - xiii. Serial number, installation date and confirmation of up to date inspection of double check valve in accordance with The City of Chestermere Parks Department procedures.
 - xiv. Provide zone flow rates and a precipitation table.

9.5.4 FINAL ACCEPTANCE CERTIFICATE INSPECTIONS

- a. Irrigation items to be approved at a FAC inspection include:

- iii. All valves, valve boxes, sprinkler heads or other irrigation sprinkler system components are undamaged and in good working condition;
- iv. All valve boxes are flush and set to the approved final grade;
- v. All valve boxes are free of debris with the valve assemblies exposed as per specification.
- vi. Provide a copy of the double check valve assembly test, by a licensed tester, showing the assembly is operating properly, done yearly, in the spring.

NOTE: *The municipal address of the site shall be indicated on the testing and inspection report.*

- vii. All zone control valves and drain valves are functioning properly with no leakage through the valve.
- viii. All heads are in a vertical position and installed at a depth recommended by the manufacturer.
- ix. All heads must be activated and operating to provide necessary coverage with the arc set as designed and with minimum overspray outside of the park property.
- x. Maintenance manuals are to be submitted to The City prior to FAC approval for all optional amenities associated with irrigation and/or water systems (i.e. water features, fountains, pumps, booster pumps, spray pools, etc.).
- xi. Temporary irrigation systems shall be removed and their water services shall be "killed" (i.e. removed to the water main). Provide certification from Parks Department that this has been completed to their satisfaction.
- xii. Submit a completed Parks Meter Record form and Irrigation Information Sheet.

NOTE: *The irrigation information sheet must contain actual calculated values, not the standard numbers out of the catalogues.*

- b. FAC's with an irrigation system will require winterizing completed by the developer. If there are noted issue in the spring due to improper winterization the developer will be responsible for the repairs.

9.6 MATERIALS

9.6.1 TESTING

The Contractor shall have an approved set of drawings and specifications available prior to calling The City of Chestermere Parks Department for an inspection. All installations require inspection acceptance from The City.

9.6.2 SUBSTITUTIONS

For substitutions, supply material with descriptive literature and samples, at least three weeks before commencement of work. Any substitutions must meet or exceed specifications and performance standards of proposed system, and be approved by the Parks Department, without any additional cost to The City of Chestermere Parks Department.

9.6.3 PIPING AND FITTINGS

- a. All piping on downstream side of parks water service shall be: NSF or CSA B137.3 certified series 160 PVC with schedule 40 fittings and schedule 80 nipples; or high-density polyethylene pipe using butt fusion or electro fusion according to manufacturer's recommendations and CGSB 41-GP-25 M. Medium density polyethylene pipe series 100 will be acceptable as laterals under extensive hard landscaping, shrub beds and as "pigtailes".

All polyethylene pipe, tubing, and fittings furnished under this specification shall conform to all applicable provisions and requirements of the latest revision of AWWA C901, C906, or CSA B137.1 and, by inclusion, all appropriate standards referenced therein.

- b. Expansion couplers of appropriate size shall be used at a minimum spacing of every 30.0 m or as required.
- c. All fittings, valves and double check valve assemblies will be sized to fit the downstream pipe diameter as illustrated in the irrigation.
- d. For medium density installations, all fittings shall be double clamped with galvanized or plastic inserts as per 9.5.4 a(i) Swing Joints/Risers listed below.
- e. No gaskets shall be used.
- f. Fittings shall be molded or fabricated by the pipe manufacturer.
- g. Only CSA Series 100 medium-density poly pipe may be used as laterals in extensive shrub bed installations. 25 mm poly pipe may be used in shrub beds if the approved drawing shows the changes in pipe size. Use 25 mm, triple swing assemblies and reduce to the appropriate size at the last elbow. ½ inch triple swing assemblies are only acceptable on MDPE shrub bed laterals with spray heads using ½ inlets. Swing joints are to be installed to lateral using saddles or insert "T's" and elbows.

9.6.4 SWING JOINTS AND RISERS/SPRINKLER

- a. Swing Joints/Risers:
 - i. Approved Swing Joints: 1/2" and 3/4" spray heads can utilize SJ Models 6" and 12" swing joints. Do not restrict flow or downsize.
 - ii. 1" and up Swing joints shall be three (3) 25 mm elbows using galvanized steel or PVC elbows, nipples and brass saddles.
 - iii. All risers for shrub beds shall be galvanized or Schedule 80 PVC and bushed down after the final elbow. A tee bar stake will be used and will be double clamped.
- b. Spray Bodies:
 - i. The following pressure compensating spray heads or an approved equal shall be used. Hunter Institutional 04, 06 & 12 heads.
NOTE: TORO 570Z-PRX is not approved.
 - ii. The sprinkler heads shall be described on the drawings, and conform to manufacturer's performance standards for durability and operation, i.e. operating pressure, gallonage, and nozzle size.
 - iii. Where quick couple valve systems are used, supply one sprinkler head and one valve key for every four quick coupler valves installed.
 - iv. The sprinkler shall be a fixed spray type, capable of covering a 2.0 m to 5.5 m radius at 30 psi with a full circle discharge rate of approximately 5 gpm.
 - v. The sprinkler shall have radius adjustment capabilities from top of the nozzle.
 - vi. The sprinkler shall be available in 4", 6" and 12" pop up.
 - vii. The sprinkler shall have heavy-duty riser seal to eliminate excess flow-by.
 - viii. The sprinkler shall have optional drain check valve.
 - ix. If the static water pressure in a lateral zone or the entire system exceeds the maximum listed operating pressure in an irrigation manufacturers performance chart (i.e. Hunter SRS = 40 psi), then a pressure reducing device must be installed in the head, on the lateral line or after the meter.
 - x. The sprinkler shall have ratcheting riser features on all bodies for easy adjustment.
 - xi. The sprinkler shall have 1/2" NPT female thread.
 - xii. The sprinkler shall have a five (5) year, over-the-counter warranty (not pro-rated).
- c. Sprinkler: *(For Areas Less than 12.0 m in Width)*

- i. The following sprinklers or an approved equal shall be used: Hunter I-20 ADS; Hunter I-20 36S; MP Rotator nozzles shall be installed on approved pressure compensating spray head bodies.
 - ii. The sprinkler shall be of the gear driven rotary type, capable of covering a 5-15 m radius at 50 psi with a discharge rate of 3-10 gpm. The sprinkler shall be available with interchangeable nozzles. The sprinkler shall have radius adjustment capabilities by means of a stainless-steel adjustment screw.
 - iii. The sprinkler shall be commercial duty available in both full circle and adjustable part circle configurations. The adjustable unit shall have the capability of adjustment in all phases of installation, i.e. before installation and after installation static and while in operation. Pop-up versions of the sprinkler shall have a ratcheting type riser assembly for final arc orientation.
 - iv. The sprinkler shall have a minimum of 3" pop up. The sprinkler shall have a rubber cover.
 - v. The sprinkler shall be equipped with a drain check valve to prevent low head drainage and be capable of checking up to 8 feet (2.40 m) in elevation changes. The sprinkler shall be equipped with a stainless-steel set screw for locking the threaded cap to the body.
 - vi. The sprinkler unit shall have a 3/4" NPT female thread inlet. The sprinkler shall be serviceable after installation in the field by unscrewing the body cap, removing the riser assembly and cleaning the inlet filter screen.
 - vii. The body of the sprinkler shall be constructed of non-corrosive heavy-duty ABS and the pop-up riser assembly shall be encased in stainless steel. The sprinklers carry a five-year over the counter exchange warranty (not pro-rated).
 - viii. If the static water pressure in a lateral zone or the entire system exceeds the maximum listed operating pressure in an irrigation manufacturers performance chart (i.e. Hunter I-20 with #4 nozzle = 60 psi), then a pressure reducing device must be installed in the head on the lateral line or after the meter.
 - ix. Sprinklers should be supplied by a local distributor to allow for product availability within 2-3 weeks.
- d. Sprinkler: (Standard for Public Landscape Areas)
- i. The following sprinklers or an approved equal shall be used; Hunter I-25 ADS; Hunter I-25 36S; Hunter I-60;
 - ii. The sprinkler shall be of the gear driven rotary type, capable of covering a 12 m – 18 m radius at 50psi with a discharge rate of 7-10 gpm. The sprinkler shall be available with interchangeable nozzles. The sprinkler shall have radius adjustment capabilities by a stainless-steel adjustment screw. Arc adjustment should be accessed at the top of the sprinkler without having to take the sprinkler apart.
 - iii. If the static water pressure in a lateral zone or the entire system exceeds the maximum listed operating pressure in an irrigation manufacturers performance chart (i.e. Hunter I-25 with #7 nozzle = 70 psi), then a pressure reducing device must be installed in the head on the lateral line or after the meter.
 - iv. See section c. Sprinkler (for Areas Less than 12m in Width) above.
- e. Flood Bubblers: Are no longer accepted in City of Chestermere.

9.6.5 CONTROLLERS (DETAIL SHEET COCH-LS #90-91) AND VALVES (DETAIL SHEETS COCH-LS #66-80)

- a. All irrigation controllers/cabinets are to be setup as non-metered sites.
Exceptions where metering is required:
 1. Sites that involve heavy usage – storm ponds with pumps and/or valve operations
 2. Sites where services have been added from the cabinet to operate lighting, etc.

3. If a third party is actually the major user of energy and The City of Chestermere Parks Department is the site owner.
- b. All irrigated sites will include the installation of an irrigation central control controller compatible with The City of Chestermere Parks water management system. Currently the City of Chestermere Parks uses the Toro Sentinel with an ESB Flow-U-Lator To-Tal-O-Tron in general the following guidelines shall be followed:
- Sites with between 4 & 23 zones may utilize Toro Sentinel with Flow-U-Lator in either 12 or 24 station configuration and either AC or DC/Solar configuration;
 - Sites requiring 24 or more zones may utilize Toro Sentinel with Flow-U-Lator controllers in the appropriate configuration.

The communication system will depend on the location of the site and may include 450 MHz radio, 800 MHz radio, GPRS or combinations of the preceding.

Designers are required to communicate with the Parks Department prior to formal submission of the designs plans for approval by Parks to fine tune the selection of controllers and communication hardware.

ESB flow-U-Lator To-Tal-O-Tron Is used to provide K factor translations and shall be wired with #14 AWG RED, 2 CONDUCTOR PAIGE (P7350) ELECTRIC TWO-WIRE CABLE PATH c/w SPARE #14 AWG BLUE WIRE PAIGE (P7001D) From the controller to the meter box.

- c. For outdoor installation the controller shall be mounted in an approved cabinet, ---fixed to a concrete base, as per detail sheets **COCH-LS #90-92**.
- d. Zone control valves shall be CSA certified as Class II power limiting circuit low voltage (i.e. 24 volt) operated only. Closing time for valves shall not be less than 5 seconds.
- e. Zone control valves shall be electrically operated and self cleaning with the ability to withstand 200 psi and of a make and model compatible with the designed system. Hand operated valves shall be installed on the upstream side of every electric valve.
- f. Wiring to and from the controller and valves shall conform to the Canadian Electric Code and any other regulatory conditions which govern this type of installation.
- g. All wire shall follow irrigation lines where appropriate. (detail sheets **COCH-LS #67-69**)
- h. Where wiring leaves pipe alignment, place in conduit. Below ground – PVC is acceptable, above ground – galvanized conduit must be used.
- i. Splices shall be made waterproof with the use of an acceptable outdoor waterproof wire connector. Field splices will be identified, looped and located in a 250 mm diameter lockable irrigation box.
- j. 110-volt wiring shall be colour coordinated to be different from 24-volt wire where used. Install all 110-volt wire in accordance with Canadian Electrical Code. Install all 110-volt wire in grey PVC electrical conduit.

Electrical conduit shall be trenched, not ploughed. All 110-volt electrical conduits shall be marked with a continuous yellow caution tape, placed directly over the conduit, 300 mm from the top of the conduit. Where satellite controllers are installed, colour code all wiring according to the satellite.

NOTE: *Temporarily locate the 110-volt wire drop-off with a 4X4 stake until a controller is installed.*

- k. Valve Signal Wires and Common Wires (detail sheets **COCH-LS #67-69**)
- Use continuous wire runs wherever manufacturers wire roll sizes allow.
 - Calculate the voltage drop on zone signal wires and common based on the furthest distance run and the maximum number of valves that can simultaneously be activated on that leg. The value will be based on the abilities of the controller specified. Size wires accordingly and indicate calculations and designed wire sizes on design plans and as-built.

- When making field splices or valve wire connections, the length of wire for all signal wires or common wires is to extend at least 12” out of the box before making the watertight connector.
 - Common to be sized one size larger than signal wire (i.e. If signal 14 ga then common to be 12). One common wire per hectare of zone valves or one common wire per 10 signal wires.
- i. Spare Wires
- Provide one (1) spare wire per wire run for each group of five (5) valves or less. The spare wire shall be looped in each valve box to extend 300 mm above the valve box and be terminated in the fifth or last valve box.
 - Provide one (1) spare 12-gauge common wire for each leg of the mainline, terminating at the end of the mainline.
 - Use continuous wire runs wherever wire roll sizes allow.
 - Have a loop of 0.5 m of spare wire coiled into each valve box that the spare wires run through.
 - Allowable voltage drop over distance (to be calculated and inserted).
 - For redundancy, provide two spares per (ha) or less of park size and a minimum of two spares per multiple of 5 valves per mainline run.
 - For future expected expansion, there will be 10 additional wires per hectare (ha) of expansion, plus an oversized common.

9.6.6 WIRING REQUIREMENT TORO SENTINAL CENTRAL CONTROL CONTROLLERS

Toro Sentinal controller: The total valve operating capacity of the controller ordered must include an extra valve circuit for the Master Valve.

- The controller circuits have one common wire connection for each group of four valve wires. The field wire gauges are as per other wire specification, i.e. 12 ga for common & 14 ga for valves. The valves grouped together on the one common connection should follow the valve box numbering order, i.e. follow the flow of water from the point of supply and follow any change of direction to the right. If the four valves in a group are in opposite directions at a tee in the main line, use a second common wire to the other valves but plan wiring so there are groups of four, e.g. for one four valve group: if one valve is to the right of the tee, this would have a combination of one common with one valve, leaving the three valves to the left to be connected to a second common.
- Follow the groupings of four, and when the total valve count is not a combination of four, have only the last grouping of valves wired at less than four valves.
- This standard must be followed to ensure that the Controller’s valve operation potential is maximized.

Toro Sentinal Controller:

- The total valve operating capacity of the controller ordered must include an extra valve circuit for the Master Valve.
- The controller circuits have one common wire connection for each group of six valve wires. The field wire gauges are as per other wire specification, i.e. 12 ga for common & 14 ga for valves. The valves grouped together on the one common connection should follow the valve box numbering order, i.e. follow the flow of water from the point of supply and follow any change of direction to the right. If the six valves in a group are in opposite directions at a tee in the main line, use a second common wire to the other valves but plan wiring so there are groups of six, e.g. for one six valve group: if two valves are to the right of the tee, these would have a combination of one common with two valves, leaving the four valves to the left to be connected to a second common.
- Follow the groupings of six, and when the total valve count is not a combination of six, have only the last grouping of valves wired at less than six valves.

- This standard must be followed to ensure that the Controller's valve operation potential is maximized.

9.6.7 ELECTRIC VALVES (DETAIL SHEETS COCH-LS #66-74)

- a. A Griswold GP or Rain Bird GB series or Glass filled nylon constructed plastic electric valve or an approved equal shall be used.
- b. Performance Features
 - i. Continually cleans itself without screens or filter to clean or replace.
 - ii. Works dependably in effluent or dirty water containing:
 - Sand
 - Silt
 - Algae
 - iii. Closes slowly without a hammer or chatter.
 - iv. Has a flow control stem.
 - v. Has a manual open/close control.
- c. Technical Features
 - i. Available sizes –3/4:" to 2."
 - ii. Body configuration -globe.
 - iii. Pressure rating -200 psi.
 - iv. Flow range -1.0 to 180 gpm.
 - v. Power requirements -7.2 VA holding; 10.8 VA in rush
 - vi. Operating voltage range 17-40.
 - vii. Maximum wire run #14 wire -1,460 m.
 - viii. **Warranty -5 years.**

9.6.8 GATE VALVES (DETAIL SHEET COCH-LS #75)

- a. Gate valves for drainage and flow control shall be PVC or bronze body with solid wedge disk, non-rising stem, removable handle and a resilient rubber ring seal with a minimum pressure rating of 10kg/cm². All gate valves shall be installed in an upright position for accessibility.
- b. Valves – 1/4" to 3": A Red & White 280A must be used or an approved equivalent that meets the following criteria:
 - i. Materials

NAME OF PARTS		ASTM SPECIFICATIONS	
Body		Cast Bronze	B62-C83600
Bonnet		Cast Bronze	B62-C83600
Stem		Copper Alloy Rod or Cast Bronze	B21-C47940 or B505-C83600
Disc		Cast Bronze	B62-C83600
Stuffing Box	1/4 – 2 1/2	Brass Rod	B16-C83600
	3	Cast Bronze	B62-C83600
NAME OF PARTS		ASTM SPECIFICATIONS	
Packing Nut	1/4 – 2 1/2	Forged Brass	B283-C37700
	3	Cast Bronze	B62-C83600
Gland		Forged Brass	B124-C37700
Gland Packing		Non-asbestos Packings	T#2966-NA
Hand-wheel	1/4 - 1/2	Zinc Alloy Die Casting	B86-Z33520

	¾ - 3	Aluminum Alloy Die Casting	B85-A03840
Wheel Nut		Steel (zinc plated)	A563-Gr.A
Name Plate		Aluminum Plate	B209-1100

ii. Dimensions

Mark	Size	1/4	3/8	1/2	3/4	1	1 1/4	1 1/2	2	2 1/2	3
L	in	1.69	1.77	1.97	2.20	2.56	2.83	3.11	3.35	4.21	4.57
	mm	43	45	50	56	65	72	79	85	107	116
H	in	3.58	3.58	3.78	4.33	4.88	5.63	6.45	7.60	9.29	10.71
	mm	91	91	96	110	124	143	164	193	236	272
D	in	1.89	1.89	2.17	2.48	2.76	3.15	3.54	3.94	4.33	4.92
	mm	48	48	55	63	70	80	90	100	110	125
Weight											
	lb	0.71	0.66	0.88	1.17	1.76	2.45	3.53	5.36	8.36	11.9
	kg	0.32	0.30	0.40	0.53	0.80	1.11	1.60	2.43	3.72	5.62

iii. Working Pressure

	Working Pressure Non-Shock	Test Pressure	
	Cold Water, Oil, Gas	Shell (Water)	Seat (Air)
Saturated Steam			
PSI	200	300	80
BAR	13.8	20.7	5.5
8.6			

NOTE:

- *End threads conform to the female international standard pipe threads.*
 - *These valves conform to the requirements of MSS SP-80.*
- c. Valves 100 mm or larger to be resilient seat flanged valve, a Watts 405RW or approved equal with a 15 MM test cock.

9.6.9 DOUBLE CHECK VALVE ASSEMBLY (DETAIL SHEETS COCH-LS #85-89)

- a. The term "double check valve assembly" (DCVA) shall mean an assembly composed of two independently acting, approved check valves, including tightly closing shut-off valves with resilient seats located at each end of the assembly and fitted with properly located test cocks as per CSA B64 series-1976. All DCVA's must conform to The City of Calgary Water Resources Standard Specifications, latest edition, and capable of being installed in field locations with a drainage function.
- b. In addition, the device must be drainable, in place, without any dismantling, adjustments or movement of the assembly, through the use of a test cock or drain valve, as approved and certified by CSA.
- c. The 150 mm DCVA shall be a WATTS – 757N (detail sheets *COCH-LS #88-89*) or approved device of equal dimension to allow the assembly to fit into a standard box.

9.6.10 BRASS SADDLES, TEES OR CROSSES

See detail sheets *COCH-LS #81-82*.

9.6.11 IRRIGATION BOXES

- a. Where manufactured irrigation boxes are used, they shall be of heavy-duty weight polyethylene and capable of being extended, withstanding the weight of a heavy tractor on their surface, and shall have a locking capability (clearances noted on details).
- b. Gravel beds in boxes shall consist of clean, washed 19 mm gravel with an area marginally larger than box opening for the depth of gravel and the distance the gravel shall be kept from the lowest point of the irrigation system.
- c. The double check valve assembly box and zone control valve boxes shall be designed into a location site where the final grade of the surrounding ground does not carry overland water drainage into the valve boxes.
- d. Wire Splices Box
- i. Body (Carson 910-10-4 or an approved equal)
 - Top inside diameter 9 1/4".
 - Top outside diameter 10".
 - Bottom inside diameter 11 3/4".
 - Bottom outside diameter 13".
 - Body of the box to be heavy duty polyethylene weighing 3 lbs.
 - Depth 10 1/4".
 - Colour green.
 - ii. Lid (Carson 910-4 or an approved equal)
 - Lid of the box to be heavy duty polyethylene weighing 1 1/2 lbs.
 - Twist lock lid.
 - Come with 3/8 x 1 3/4" lock bolt for slot screwdriver.
 - Marking on lid to be "Irrigation Wire Splice Box".
 - Must have cover lift holes.
 - Must be 2" in depth.
 - Colour green.
 - iii. Wire Splice Connectors: 3M DBY/DBR's or equivalent.
- e. Drain Boxes
- i. Box (Carson 1419 or an approved equal)

- Body of the box to be heavy duty polyethylene weighing 7 lbs.
 - Depth 12".
 - Outside top width 11 3/4".
 - Outside top length 17".
- ii. Lid (Carson 1419-4L or an approved equal)
- Lid of the box to be heavy duty polyethylene weighing 3 1/2 lbs.
 - Lid must be over the rim cover or T-lid.
 - Must have locking 3/8" L-bolt with 9/16" head, non-corrosive, metal detector sensitive ball.
 - Marking on the lid to be "Irrigation Drain Box."
- Outside bottom width 15 7/8".
 - Outside bottom length 21 1/8".
 - Inside bottom width 14 1/8".
 - Inside bottom length 19 1/4".
- f. Drain Box Extensions
- i. Boxes (Carson 1419-6X or an approved equal)
- Body of box must be made of heavy-duty polyethylene weighing 5 lbs.
 - Depth 6 3/4".
 - Outside top width 12".
 - Outside top length 17".
- Lift slot.
 - Outside top width 12 1/2".
 - Outside top length 18".
 - Outside insert width 10 1/8".
 - Outside insert length 5 3/8".
 - Must be 2 1/8" in depth.
 - Lid must be interchangeable with box and extensions.
 - Colour green.
- g. Control Valve Box, Isolation Valve Box, Meter Valve Box and Gate Valve Outlet Box
- i. Boxes (For valves 50 mm or smaller Carson 1220-12 or an approved equal and for valves larger than 50 mm Carson 132412 or 1324-15 or an approved equal)
- Body of the box must be made of heavy-duty polyethylene weighing 8 lbs.
 - Depth 12".
 - Outside top width 14 3/4".
 - Outside top length 21 1/2".
- Outside bottom width 14".
 - Outside bottom length 19".
 - Inside bottom width 12 1/8".
 - Inside bottom length 17 1/4".
 - Colour green.
- ii. Lid (Carson 1220-3L or 1220-5L or 1324-3L or an approved equal)
- Lid of the box to be non-hinged made of heavy-duty polyethylene weighing 5 lbs.
 - Must have locking 3/8" L-bolt with 9/16" head, non-corrosive, metal detector sensitive bolt.
 - Lift slot.
 - Outside width 13 1/4".
 - Outside length 19 3/4".
 - Must be 1 3/4" in depth.
- Outside bottom width 19".
 - Outside bottom length 25 3/4".
 - Inside bottom width 17 1/4".
 - Inside bottom length 24".
 - colour green.
- Marking on the lid will change depending on the use of the lid; i.e.:
 - Irrigation Control Valve Box.
 - Irrigation Isolation Valve Box.
 - Irrigation Meter Valve.
 - Lid must be inter-changeable with box and extensions.
 - Colour green.
- h. Control Valve Box, Isolation Valve Box, Meter Valve Box and Gate Valve Outlet Box Extensions
- i. Box (Carson 1220-6X or an approved equal)
- Body of the box must be made of heavy-duty polyethylene weighing 4 lbs.
 - Depth 6 3/4".
- Outside top width 14 3/4".
 - Outside top length 21 1/2".
 - Outside bottom width 17 5/8".
 - Outside bottom length 24 3/8".

- Inside bottom width 15 3/8".
 - Inside bottom length 22 1/8".
- i. Double Check Valve Assembly Box
- i. Box (Carson 1730-18-3L or an approved equal)
- Body of the box must be made of heavy-duty polyethylene weighing 25 lbs.
 - Depth 18."
 - Top outside width 19 1/2".
 - Top outside length 32 1/2".
 - Bottom outside width 27 1/4".
 - Bottom outside length 40 1/2".
 - Bottom inside width 24 1/4".
 - Bottom inside length 37 1/2".
 - Colour green
- ii. Lids (Carson 1730-3L or an approved equal)
- Lid of the box to be non-hinged made of heavy-duty polyethylene weighing 10 lbs.
 - Must have locking 3/8" L-bolt, with 9/16" head, noncorrosive, metal detector sensitive bolts.
 - Lift slot.
 - Outside width 17 1/2".
 - Outside length 30 1/2".
 - Must be 2" in depth.
 - Marking on the lid to be "Double Check Valve Assembly Box."
 - Colour green.
- iii. See detail sheets **COCH-LS #99-101** for 100 mm DCV box and lid assembly complete with access door for meter reading.

9.6.12 BACKFILL MATERIAL

- a. Backfill material for pipe trenches within 150 mm of pipe shall be clean approved sand fill or gravel less than 12 mm diameter in size, free of stones and sharp objects capable of damaging pipe.
- b. Excavated material may be used for backfilling only when approved by The City of Chestermere Parks Department.

9.6.13 SLEEVING

- a. Sleeving shall be PVC SDR 35 or PVC C-900 (bell and spigot) pipe to The City of Calgary Water Resources Standard Specifications for Sewer Construction Sec. 402.02.02 or approved equal.
NOTE: *PVC SDR 35 shall be backfilled in accordance to The City of Calgary Standard Specifications for Sewer Construction. PVC C-900 may be backfilled with native material free of organics and shall be compacted to 98% SPD.*
- b. Diameter of conduit shall be twice the diameter of the irrigation pipe. The size of the conduit shall be measured in 50 mm increments or as noted on the drawings.
- c. Extend sleeving a minimum of 1.0 m beyond edge of pavement of amenity area. Tape ends to prevent debris filling.
- d. All wire for automatic systems will not go in the same sleeve as the irrigation pipe; wire will have its own sleeving. Amount of wires will determine the size of the sleeve as follows:
 - i. 2 to 14, #14-gauge wires: 2-inch (50 mm) sleeve;
 - ii. 14 to 40, #14-gauge wires; 4-inch (100 mm) sleeve.
 - iii. 40 to 70, #14-gauge wires; 4-inch (10 mm) to 6-inch (150 mm) sleeve.

Existing Irrigation Systems: DO NOT CUT wires or pipe. Use one sleeve as per above and cut sleeve down its length to create two half shells; excavate under pipe and wires; place one half of sleeve under wire and pipe, place other half above pipe and wire, then clamp two halves together with two broken pipe repair clamps.

9.6.14 MISCELLANEOUS COMPONENTS

All miscellaneous components, such as air relief valves (detail sheet *COCH-LS #79*), concrete vaults or meter boxes, valve markers and caps, etc., shall be of the type and size as indicated on the drawings or details. Install according to approved manufacturer's directions or at the direction of The City of Chestermere Parks Department.

9.6.15 THRUST BLOCKS

- a. Local conditions will determine the type and extent of thrust blocking to be used. Obtain approval from The City of Chestermere Parks Department on the base method (i.e. concrete, rock, rebar or a combination of the former) before proceeding.
- b. All lines 100 mm and over will require concrete thrust blocks. Concrete will be Class B as per 310.00.00. The City of Calgary Roads Construction Specifications.

9.7 LAYOUT

- a. Stake out entire system, including locations of sprinkler heads and/or quick coupler valves, double check valve, zone control valves and tees and elbows for the pipe as well as the layout of all the piping, park water service, and the electrical drop. Confirm that layout is within project boundaries and property lines and ensure all surface hardware, excluding sprinklers, is installed outside of sports fields and the three-meter buffer zones. Under exceptional circumstances and subject to the approval of Parks Department limited encroachment of surface hardware into the buffer zone may be acceptable. Heads shall be spaced to ensure head to head coverage. Where deviation from the design drawing is anticipated, submit in writing, as required, change requests to The City of Chestermere Parks Department for approval.
- b. Verify on site, the location of all sleeving under paving and adjust to suit.
- c. Verify the location of all underground utilities and use standard precautions when working near such. Make good all damages at Contractor's cost.
- d. Set back park water services (detail sheets *COCH-LS #108-109*) a minimum of 2.5 m from pathways, hard surfaces and trees, and set back lateral irrigation lines a maximum of 0.50 m from property lines.
- e. Have layout inspected and approved by The City of Chestermere Parks Department before commencement of work.
- f. Due to changes in landscape elements, it may be necessary to adjust the spacing of the sprinklers in the field. Such changes that do not require extra materials or labour shall be done at no extra cost to The City of Chestermere Parks Department. If such changes result in extra cost, all such changes shall be approved in writing by The City of Chestermere Parks Department before proceeding with work.

9.8 COORDINATION

Fully coordinate work with other trades, so as not to delay work progress. If the water or electric service exists from a building, coordinate work with the building owner to ensure proper connections to services.

9.9 TRENCHING

- a. Ensure that the grade has been set and approved by City of Chestermere Parks Department before commencing trench operations.
- b. Width of trench shall be a minimum of three times the diameter of the pipe. Main line pipe depth shall be in accordance with the following table to ensure adequate coverage:

Main Line Pipe Depth

Pipe Size	Min. Depth to Top of Pipe	Max. Depth of Bottom of Pipe	Imp. Depths
2" (50 mm)	350 mm	600 mm	14" – 24"
4" (100 mm)	350 mm	650 mm	14" – 26"
6" (150 mm)	400 mm	750 mm	16" – 30"
Lateral Zone Piping Depth			
Pipe Size	Min. Depth to Top of Pipe	Max. Depth of Bottom of Pipe	Imp. Depths
2" (50 mm) zone lines depth	300 mm	450 mm	14" – 16"

- c. Bed with suitable material (See 9.5.12 Backfill Material) to the proper depth and compact to meet the approval of The City of Chestermere Parks Department.
- d. The Contractor shall repair any settlement of the trenches by bringing them to grade with topsoil and sodding.
- e. Place sleeving as required to enclose piping under paved areas. Depth of sleeving shall match table for depth of pipe, 1000 mm under roadways or as approved by The City of Chestermere Parks Department.

9.10 INSTALLATION

- a. Submit a schedule as required for the proper installation of the system. Coordinate irrigation installation with other aspects of site development to ensure proper construction and reduce the possibility of damage to and by other trades. All work shall conform to approved design drawings.
- b. Install all piping so it is not bent from a straight line in excess of the manufacturer's recommendation for local conditions and with a minimum fall of 0.5% to drain boxes.
- c. Make all joints and connections tight and in accordance with manufacturer's recommendations.
- d. Ensure the glue adhesive is appropriate for the ambient temperature at the time of installation and is used in accordance with manufacturer's specifications.
- e. Install risers with saddle tees (detail sheets *COCH-LS #81-84*) firmly connected and plumbed.
- f. All sprinklers are to be adjusted and set flush with final grade using the three elbow swing joint (detail sheets *COCH-LS #81-82*). Ensure the horizontal nipple is no more than 45° out of level when setting sprinklers. Where utility easements or property lines preclude the standard assembly, a "pig tail" swing joint shall be used (detail sheet *COCH-LS #83*).

NOTE: *Pig tails shall be excluded in utility easements that contain concrete drainage swales. However, the Developer is responsible for repairs to the irrigation system during the maintenance period if remedial work is performed by The City within the drainage easement.*

- g. All backflow prevention assemblies (detail sheets *COCH-LS #85-89*) must be installed in accordance with the City of Calgary's Wastewater Plan 40M2006 - <http://www.calgary.ca/PDA/DBA/Pages/Urban-Development/Publications.aspx> and the Alberta Plumbing and Drainage Act Regulations. Backflow prevention assemblies must be tested and tagged upon installation and annually thereafter prior to activating the system that year.
- h. Ensure that such items as shrub heads are set at the proper height to obtain adequate coverage.
- i. For automatic systems:
 - i. Lay the wire in the trench with sufficient slack to accommodate backfilling and then backfill with suitable material (see 9.5.12 Backfill Material) prior to installation of the piping. (detail sheet *COCH-LS #67*)
 - ii. Ensure a green 14-gauge tracer wire is installed for lateral lines.
 - iii. Provide a minimum of 600 mm coiled loops of wire at all control valves and changes in direction.
 - iv. Wiring necessary to activate the controller and valves must be located in a conduit (see 9.5.13 Sleeving) when located in buildings or under all paving.

- v. If a controller is located in a building, mount within approved cabinet (detail sheet *COCH-LS #90*), center cabinet 1650 mm above floor) capable of locking and securing controller and waterproof if necessary.
- vi. Block all changes of direction and pipe endings (tee, elbows 45° and 90°, plugs). If concrete thrust blocks are used, protect pipe from spillover.
- vii. Ensure that the last sprinkler head tee is not set closer than 150 mm from the pipe end.
- viii. Install drain valves and boxes (detail sheet *COCH-LS #111*) at appropriate locations to accommodate the slope of the land and the size of the irrigation system. Ensure that all heads, valves and drains are not set closer than 1.0 m from each other. If the mainline is less than 10 m in length drain pits will not be required.
- ix. Install one 25 mm curb stop drain valve (detail sheet *COCH-LS #110*) at each end of a conduit under a roadway to ensure adequate drainage.
- x. Install Park Water Services as per details sheets *COCH-LS #108-109*.
- xi. Where provided for by The City of Chestermere Parks Department, install a combination 50 mm Master Valve with a Water Meter as per detail sheet *COCH-LS #78*.

9.11 BACKFILLING

- a. After an open trench inspection and receipt of written approval by The City of Chestermere Parks Department, backfill with an approved fill (see 9.5.12 Backfill Material).
- b. Place backfill in 150 mm lifts, placing and compacting all lifts to 85% S.P.D. until subgrade complete. Place topsoil, seed and/or sod as specified.
- c. Adjust sprinkler heads to the correct spray angle to provide adequate coverage without excessive overspray.
- d. All irrigation systems shall be flushed out in a satisfactory manner to remove accumulation of dirt and other deleterious matter. Flush all laterals in a manner approved by the manufacturer to prevent clogging of sprinkler screens or nozzles.
- e. In the event that finished landscape grades are changed more than 150 mm, either lower or higher, and thereby compromise the initial intent of the irrigation specifications, at the direction of The City of Chestermere Parks Department, the irrigation piping and fixtures may have to be adjusted to meet the specifications. Drain valve assemblies may require a change to the standard 25 mm curb stop size.
- f. Repair as required upon final testing by The City of Chestermere Parks Department.

9.12 CLEAN UP

Remove off site all debris and excess material left over from installation at the end of each working day or as required.

9.13 MAINTENANCE

Protect and maintain the entire irrigation system from the time of installation until Final Acceptance Certificate is issued by City of Chestermere Parks Department

9.13.1 MAINTENANCE OF THE IRRIGATION SYSTEM SHALL INCLUDE:

- a. System Turn On
 - i. Includes: Spray painting water services and keeping them clear and exposed from overgrowth (locator markings).
 - ii. Submit and implement a weekly watering schedule for the season, which shall provide moisture to the turf and plant material as site conditions dictate.

iii. Follow all maintenance and repair procedures to ensure a completely functional system with head to head coverage according to original intent of design.

iv. Double-check valve test: Complete and submit.

NOTE: *The municipal address of the site shall be indicated on the Testing and Inspection Report.*

b. Monthly Checks

- | | |
|--------------------------|--|
| i. Controller (clock). | vi. Manual valves. |
| ii. Automatic valves. | vii. Sprinkler heads (arcs). |
| iii. Double-check valve. | viii. Boxes. |
| iv. Water services. | ix. General settling and grading problems. |
| v. Piping. | |

c. System Turn Off

i. Turn off the water supply to the irrigation system. You will have two choices:

- Stop and drain (or seal), 1/4 turn clockwise to close.
- Service valve and drain rod -service valve counterclockwise to close and drain rod is 1/4 turn counterclockwise to open.

ii. Open all drain valves on main line of irrigation system and all test cocks and drains on double check valve assembly and allow sufficient time for the water to drain out.

iii. Close all drain valves.

iv. Connect an air compressor (600cfm) to a quick coupler using a 25 mm hose (detail sheet COCH-LS #81) or to a 50 mm gate valve outlet assembly using a 50 mm hose (detail sheet COCH-LS #75) downstream of the double check valve assembly or water meter.

v. Activate all electric valves from the controller. Ensure that each zone blows "clean" of any water before proceeding to the next. After this procedure is completed, go to each electric valve and manually activate each zone to make sure you have not missed a zone. Repeat the procedure from controller to dispel any remaining water.

Turn the air compressor off and drain the main line of air, through the drain valve. Check all drain valves to make sure no water is coming out. Disconnect the air compressor. **DO NOT** leave drain valves and test cocks open for the winter.

Form 5 - Parks Irrigation Meter Sheet

MFRM000	Quality Management Document Parks Irrigation Meter Report		ISO Elem: 4.0
Owner:	Approved By:	Issue Date:	Controlled Document
<i>Irrigated Site Information</i>			
Address:		Legal Description:	
Reference Address:		Community:	Phase:
Developer:		Steward:	MGMT_NUM:
<i>Meter Information</i>			
Meter Pit Location:		Meter Size:	50 mm 100 mm 150 mm
Tag #:		Serial #:	
Install Date:		Install Reading:	
Power Source:	SOLAR ELECT	Computer Hook Up:	NO YES
RIC			
Electric Meter:	NO YES NUMBE	Outlet Tested:	NO YES
R:			
<i>Developer Inspection Information</i>			
Irrigation Contractor:		Development Inspector:	
Phone:		As-Built:	NO YES
Development Agreement #:		Development Status:	CCC FAC
		DATE:	
<i>Developer & Consultant Information</i>			
Name of Developer:		Name of Consultant:	
Contact Person:		Phone:	
<i>Meter Location Diagram</i>			
Attach map.			
REF:	Revision Date:	Revision #:	Page:
<i>Copy 1: Dev. Services</i>	<i>Copy 2: Parks Dept</i>	<i>Copy 3: Inspector</i>	<i>Copy 4: Consultant</i>

Form 6 - Irrigation Information Sheet

Irrigation Information Sheet						
Park Name:			Page		of	
Municipal Address:			P.M.M.S. Number:			
Service Address:			PROSIS Number:			
Park Hectares:	Irrigated Hectares:	Class:	Community:	Area:	District:	
Systems <input type="checkbox"/> Automatic <input type="checkbox"/> Manual Pop Up <input type="checkbox"/> Manual						
Parks Water Service Type	Service Number		Corresponding Back Up Valve			
	#1	#2	#1	#2		
Stop & Drain Service			<input type="checkbox"/> Yes <input type="checkbox"/> No		<input type="checkbox"/> Yes <input type="checkbox"/> No	
Service Valve & Service Drain						
Other			Size (mm)		Size (mm)	
Water Service size in Millimeters (mm)						
Water Service depth in Metres (m)						
Corresponding Backflow Unit			P.S.I. On Installation			
No.	Type	Make	Model	Size	Serial Number	Date Installed
1	DC <input type="checkbox"/> RP <input type="checkbox"/>					
2	DC <input type="checkbox"/> RP <input type="checkbox"/>					
Corresponding Water Meter						
No.	Make	Model	Serial Number	Size	W.W. Tag No.	Date Installed
1						
2						
Field Drains						
Total No.	Gate Valves	Drain Rod	Drains Located			
			<input type="checkbox"/> D.C.V. <input type="checkbox"/> Main Line <input type="checkbox"/> Laterals			
Components	Description (Make, Model, etc.)		Arc Size, No. of Stations	Number, Length	Nozzle Size	
Box						
Controller						
Pipe						
Sprinkler Head						
Valve						
<input type="checkbox"/> Washroom <input type="checkbox"/> Drinking Fountain <input type="checkbox"/> Display Fountain <input type="checkbox"/> Winter Service <input type="checkbox"/> Fill Up Site <input type="checkbox"/> _____ <input type="checkbox"/> _____ <input type="checkbox"/> _____						

10 LANDSCAPE MAINTENANCE

10.1 PREAMBLE

City of Chestermere Parks Department have developed these maintenance standards as a benchmark for minimum level of performance. The Development Industry at its discretion may desire to perform an increased level of maintenance. Introduction of non-permanent elements during the maintenance period must be approved by City of Chestermere Parks prior to installation. The following standards can also be found in the City of Chestermere's Parks and Recreation Open Spaces Maintenance Standards refer to that document for further explanation and details of expectations.

10.2 THE CITY OF CHESTMERE PARKS CLASSIFICATIONS

Class 1 Park: Regional parks, special interests, beaches, high end sports fields.

Class 2 Park: Neighbourhood or community parks, tot lots, median & boulevards, entrance features,

JUS, specialized dog parks, general sports fields and amenities.

Class 3 Park: ER's, natural areas, Storm ponds and surrounding MR, lineal parks, off leash dog parks.

Class 4 Park: Rough cut and undeveloped areas.

10.3 GENERAL MAINTENANCE

- No lubricant or fuel spills on turf or non-turf areas.
- No damage to turf.
- No damage to trees, shrubs or other park features such as scraped bark on trees and shrubs or bent or scraped park furniture including trimming.
- All visible litter shall be removed.
- All parks features shall be maintained in safe operating condition.
- All parks features shall meet or exceed all legislated requirements.
- All park features shall be inspected and maintained on a regular basis as scheduled or as required.
- All vandalism and/or security breaches must be reported according to procedure.
- All legislated requirements must be adhered to, such as WHMIS, ISO14001, OH&S, etc.
- No graffiti.

10.4 MOWING

Desired Results:

- All turf has been cut evenly at designated height, in a safe and efficient manner.

Class 1	3" weekly
Class 2	3" 12 – 14 days
Class 3	3" Monthly
Collector Roadway/Medians	Monthly
Natural areas along pathways	Fire cuts monthly (1 mow strip along each side of the pathway)
- Grass clippings should not be present on sidewalks, pathways or any hard surfaces for any class of park and major clumps of clipping removed.

10.5 GARBAGE RECEPTACLE EMPTYING & LITTER CONTROL

- All bags 75% full or over shall be replaced
- All garbage cans must have a plastic garbage bag inside.
- All garbage containers shall remain free of crusted garbage build-up, objectionable odors, wasps or other insects from being attracted to the garbage can.
- Area around garbage container shall be litter free. All garbage bags, hazardous material, bio-hazardous waste is to be safely disposed of according to applicable safety procedures.
- No litter should be present in parks, including large items or third party dumping or forts.

10.6 FERTILIZE

Public Notice prior to application.

- Application is even and uniform throughout.
- No spillage of fertilizer.
- No discolouring (streaking) of turf.

10.7 AERATE

- Aerator holes / cores should be 3 inches (3") deep, 3 inches (3") or less apart and about $\frac{3}{4}$ inch in diameter.

10.8 TOP DRESSING

- Accurate topsoil requirement calculations.
- No damage to turf caused by loam piles.
- Appropriate soil mixture piling.
- No top-dressing material on sidewalks or roadways.

10.9 CHEMICAL WEED CONTROL

Public Notice prior to application.

- No damage to trees, shrubs or other park features as a result of spraying operations.
- No spray (herbicide) damage to non-targeted vegetation.
- No spray (herbicide) damage within 10.0 meters of the edge of tot lots.
- All signage removed.
- The City currently applies some herbicides to control dandelions and other broad leaf weeds. All sites are assessed prior to treatment.
- We apply herbicides more often to sport fields, as they have high use and too many broad leaf weeds can cause safety issues for users and threaten the health of the turf. For other areas, we apply at a lower frequency, as they have a higher tolerance for weeds.
- The City takes the health and well-being of citizens and green spaces seriously, so all herbicides and pesticides are carefully chosen and applied to be the least toxic to off-target plants and animals. Furthermore, all pesticides and herbicides are fully certified by both the federal and provincial governments.
- Notification and application signs will be posted in the community before, during and after any necessary applications.

10.10 TREE WELL MAINTENANCE

- Tree well to mulched.
- Tree well should be free of weeds and of a standard size approximately 1.0 m in diameter.
- Mulch should be spread evenly to a depth of 4 inches (4") and not piled against or touching trunk of tree as this can rot the wood causing decay or even death of the tree.

10.11 SHRUB BED MAINTENANCE

- Mulch to be spread evenly to a depth of 4 inches (4”).
- Mulch should not be piled against the base of trees or shrubs as this can rot the wood, causing decay or even death of the plant.
- No more than 5% of shrubs dead, missing or diseased.
- No more than 5% of broken, dead or diseased shrub branches remaining in bed.

10.12 IRRIGATION MAINTENANCE

- DCV Testing.
- All repairs required in order that system operate effectively.
- No water leaking from system.
- No irrigation boxes that have lids missing or in poor state of repair. Box lids are safe and locked.
- Parks water valve and drain rod are visible and at grade.
- All sprinkler heads/turf valves are to grade so as not to be a tripping hazard.

10.13 SNOW AND ICE MANAGEMENT

Snow and ice cleared in accordance with Plan #018-11.

- Ninety-eight percent (98%) clear of snow.
- No snow piled onto shrubs or trees.
- No snow pushed onto private property.
- All pathway's and sidewalks must be cleared.

10.14 BUILDING AND JANITORIAL MAINTENANCE

Building Maintenance:

- All vandalism reported according to procedure.
- All breaches of security reported according to procedure.
- All buildings safe and secure.
- All fans, pumps, filters, furnaces, valves must be checked on a regular scheduled basis and be in working order.
- All lights and other electrical devices in working order.

Building Janitorial:

- Accumulations of water, mud and dirt must not be present on more than 5% of the floor surface (after cleaning).
- Broken glass or obvious litter must not be present.
- Smudges, spots, stains, watermarks etc. must not be present on more than 5% of any wall surface or mirrors.
- Waste and sanitary receptacles must not be more than 75% full. Overflowing conditions and piles of litter around receptacles are not acceptable.
- All dispensers (toilet paper, paper towels, etc.) shall not be less than 25% full.
- All toilets and sinks shall be operable. No plugged, leaking or overflowing toilets or sinks.

10.15 PLAYGROUND INSPECTION AND MAINTENANCE

- Inspections completed as per established inspection schedule.

- Follow all regulatory standards.
- All formal (inspection report) documentation completed.
- All minor repairs completed.
- Any major repairs scheduled as per inspection report.
- Playground safe for public use.

10.16 TREE PRUNING

- *All pruning to be completed by or under the direct supervision of a Certified Arborist (ISA).*

Desired Results:

- Tree is cleaned of all dead, diseased and broken branches.
- All clearance, both vertical and visual (for safety reasons) are maintained.
- An obvious, prominent central leader is evident (if species and growth habit of tree allows).
- Structural defects are mitigated (e.g. hazards, dead branches removed).
- The habit of growth for the species is maintained.
- No stubs, flush cuts or stumps and tearing. Final cuts should result in a flat surface with adjacent bark firmly attached.
- No more than 20% of the total live canopy and 20% of living wood on any branch removed in one season.

10.17 WATER FEATURES (PONDS AND LAGOONS)

Summer Operation:

- All areas/structures related to water feature shall be safe and secure.
- All fans, pumps, filters, valves or other water volume regulatory devices must be checked on a regular scheduled basis and must be in proper working order and documented. All documentation must be submitted prior to FAC Inspection.
- All lights and/or other electrical devices must be in proper working order.

10.18 FENCE MAINTENANCE

- No damage to trees, shrubs or other park features such as scraped bark on trees and shrubs; bent or scraped park furniture.
- No broken or bent gates or posts.
- Cable and/or fabric must be tightened as required.
- Chain link fence must be straight and at the same consistent height throughout and must be maintained in good repair (e.g. bent, misshaped, or broken fence sections).
- Wood fence must be straight and at the same consistent height throughout and must be maintained in good repair (e.g. broken boards, posts). Wood fencing is to be painted or varnished on both sides.
- No litter is to be allowed to accumulate along the fence base.

10.19 PLAYFIELDS AND COURTS

- Ensure that in all fields where shale is used, that all edges where shale meets the grass are straight.
- Shale should be loosened regularly, to a depth of 1 inch (1”).
- Ball diamond infield and soccer fields should be weed free.

- No holes in playing fields.
- Ensure that all fixtures and amenities on or around play fields are inspected regularly and maintained and documented in order to provide a safe playfield area (i.e. goal posts, backstops, players' benches, dugouts, bleachers, etc.). All documentation must be submitted prior to FAC Inspection.
- Ensure that all lighting and electrical amenities are maintained properly and in good working condition.

11 DETAIL SHEETS

Optimal Drainage Patterns for Sports Fields	COCH-LS 2
Soccer Field – Combination Major/Minor	COCH-LS 3
Soccer Field – U12-U6 Layout	COCH-LS 4
Softball Diamond – 76.2 m	COCH-LS 8
Little League Baseball Diamond – 76. m Infield.....	COCH-LS 9
Little League Baseball Diamond – 91.4 m Infield.....	COCH-LS 10
Little League Baseball Diamond – 91.4 m	COCH-LS 11
Baseball Diamond – Backstop Details	COCH-LS 12
Baseball Diamond – Backstop Details	COCH-LS 13
Baseball Diamond – Backstop Details	COCH-LS 14
Tennis Court Construction – Plan & Section View	COCH-LS 15
Tennis Court Construction – Practice Board	COCH-LS 16
Tennis Court Construction – Fencing	COCH-LS 17
Tennis Court Construction – Apron Detail.....	COCH-LS 18
Tennis Court Construction – Permanent Transom	COCH-LS 19
Tennis Court Construction – Removable Transom	COCH-LS 20
Tennis Court Construction – Net Post Details	COCH-LS 21
Tennis Court Construction – Surface Repair Schedule 1	COCH-LS 22
Tennis Court Construction – Surface Repair Schedule 2	COCH-LS 23
Tennis Court Construction – Surface Repair Schedule 3	COCH-LS 24
Track and Football Field Construction – 400 m	COCH-LS 25
Soccer / Rugby or Football Combination – Goal Posts	COCH-LS 26
Soccer Goal – Portable.....	COCH-LS 26A
Basketball Court Construction.....	COCH-LS 27
Basketball Court Construction – Goal Post Detail.....	COCH-LS 28
Basketball Court Construction- Surface Details	COCH-LS 29
Tree Planting Detail – 35 mm Caliper Trees & Smaller Bare Root	COCH-LS 30
Tree Planting Detail – 40-100 mm Caliper Trees, Backhoe Dug	COCH-LS 31

Tree Planting Detail – 40-100 mm Caliper Trees, Spade Dug.....	COCH-LS 32
Shrub Planting Detail.....	COCH-LS 33
Tree Planting – Bed Detail.....	COCH-LS 34
Tree Planting Details – Slopes	COCH-LS 35
Tree Planting Details – Tree Anchor	COCH-LS 36
Tree Planting & Trench Details – Boulevards & Medians	COCH-LS 37
Topsoil/Subgrade Preparation.....	COCH-LS 38
Sod Detail.....	COCH-LS 39
Pathway Handrail.....	COCH-LS 40
Wheelchair Ramp – Concrete	COCH-LS 43
Wheelchair Ramp – Asphalt	COCH-LS 44
Local Pathway – Typical Cross Sections	COCH-LS 45
Regional Pathway Typical Cross Sections	COCH-LS 46
Root Barrier	COCH-LS 47
Root Barriers – Locations.....	COCH-LS 48
Pathway – Culvert & Edge Detail.....	COCH-LS 50
Pathway – P-I-P Concrete Ends	COCH-LS 51
Culvert – River Rock Ends	COCH-LS 52
Concrete Paving Stone	COCH-LS 53
Retaining Wall – Dry Pack Rock	COCH-LS 55
Playground – Concrete Edge Restraint.....	COCH-LS 58
Playground Drainage – Concrete Edge Detail.....	COCH-LS 59
Post & Cable Barrier	COCH-LS 63
Concrete Splash Pads – On Public Easements	COCH-LS 64
Irrigation As-Built Drawing (Typical)	COCH-LS 65
Irrigation Field Wire Alignment	COCH-LS 67
Electric Control Valve Signal Wire Schematic	COCH-LS 68
Right Hand Valve Wiring Rule	COCH-LS 69
Isolation Valve Main Control Valve (PVC) – 100 mm	COCH-LS 72

Isolation Valve Main Control Valve (PVC) – 150 mm	COCH-LS 73
Isolation Valve Main Control Valve (PVC) – 200 mm	COCH-LS 74
Compressor Connection & Meter Test Assembly – 50 mm	COCH-LS 75
Field Gate Valve Assembly – 50 mm	COCH-LS 76
Tee Hook-Up	COCH-LS 77
Valve Hook-Up (PVC) 50mm to 50mm	COCH-LS 78
Air Relief Valve (PVC)	COCH-LS 79
Pressure Reducing Valve Assembly	COCH-LS 80
Three Elbow Swing Joint – Metal Sprinkler Head	COCH-LS 81
Three Elbow Swing Joint – Plastic Sprinkler Head	COCH-LS 82
Pigtail Swing Joint – PVC & MDPE	COCH-LS 83
Three Elbow Swing Joint – Plastic Riser & Shrub Head	COCH-LS 84
Double Check Valve Assembly – 50 mm	COCH-LS 85
Double Check Valve Assembly – 100 mm	COCH-LS 86
Detail of Spool Assembly – 100 mm & 150 mm	COCH-LS 87
Double Check Valve Assembly – 150 mm	COCH-LS 88
Double Check Valve Assembly – 200 mm	COCH-LS 89
Irrigation Controller Cabinet	COCH-LS 90
Irrigation Controller Cabinet – Concrete Pad	COCH-LS 91
Control Cabinet & Pedestal – Toro Sentinel.....	COCH-LS 92
Figure 2-Up to 64 Stations – Non-Rocky Soils	COCH-LS 93
Figure 4-Up to 96 Stations – Non-Rocky Soils	COCH-LS 94
Figure 3 – Up to 64 Stations - Rocky Soils	COCH-LS 95
Up to 96 Stations – Rock Soils	COCH-LS 96
Sphere of Influence – Ground Plate	COCH-LS 97
Sphere of Influence – Ground Rod	COCH-LS 98
Valve Box Details for Double Check Valve Assembly – 100 mm	COCH-LS 99
Double Check Valve Box and Meter Viewing with Lid – 100 mm	COCH-LS 100
Double Check Valve Box Lid with Meter Viewing with Lid – 100 mm	COCH-LS 101

Valve Box – Double Check Valve Assembly – 100 mm	COCH-LS 102
Frame with Aluminum Lid – Double Check Valve Assembly – 100 mm	COCH-LS 103
Valve Box Crossbeam Support – Double Check Valve Assembly – 100 mm	COCH-LS 104
Valve Box Crossbeam Support – Double Check Valve Assembly – 100 mm	COCH-LS 105
Double Check Valve Box – Aluminum Lid	COCH-LS 106
Double Check Valve Box – Aluminum Lid – 100 mm	COCH-LS 107
Typical Parks Water Service – 50 mm	COCH-LS 108
Typical Parks Water Service – 150 mm	COCH-LS 109
Curb Stop Assembly – 25 mm	COCH-LS 110
Drain Pit – PVC Pipe	COCH-LS 111

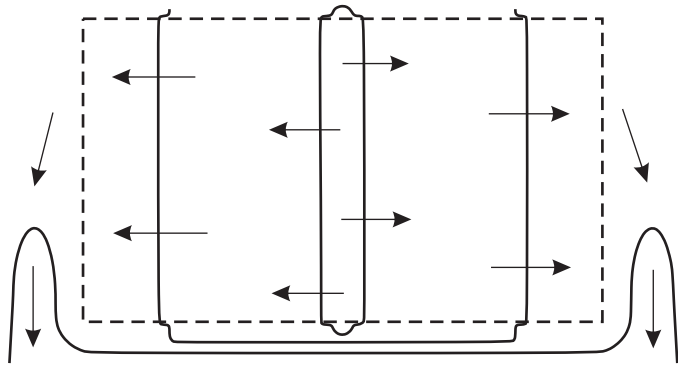

END

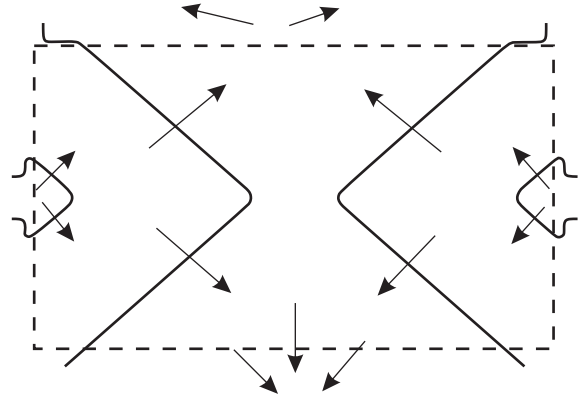

RIDGE

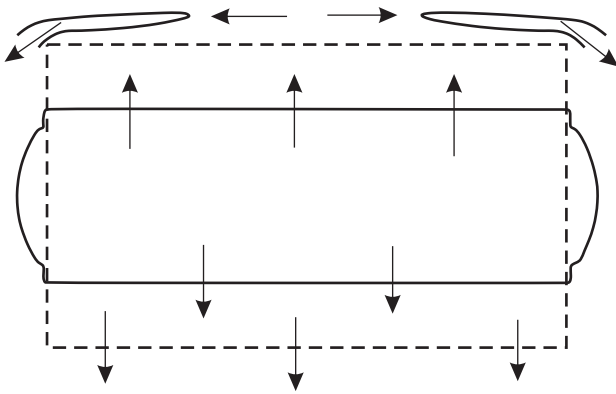

RIDGE

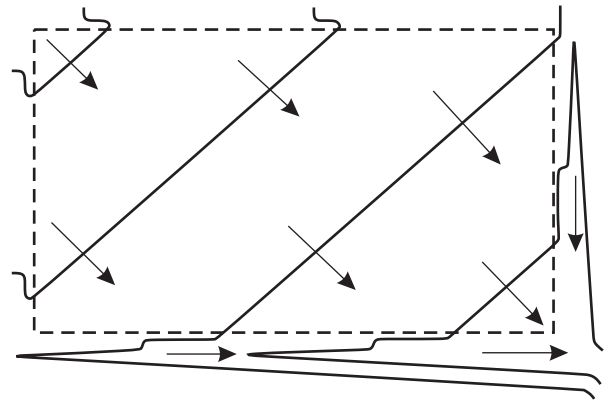

CORNER PITCH

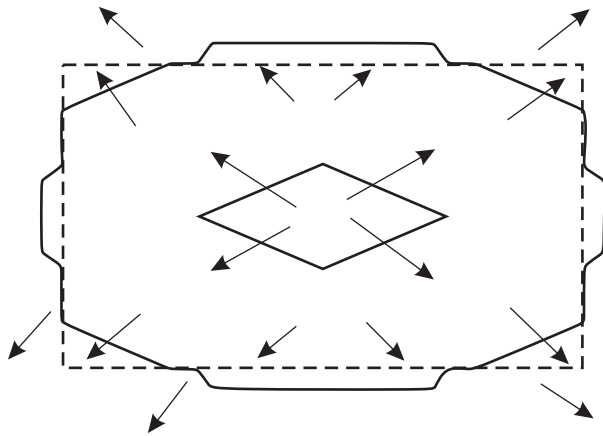

HIGH POINT

CITY OF CHESTERMERE
Development & Infrastructure
Services
Parks Department



PR.0020.11
January, 2015

SHEET TITLE:

Optimal Drainage Patterns for
Sports Fields

**LANDSCAPE STANDARDS &
SPECIFICATIONS**

SHEET NO: COCH-LS 2



DRAWN BY: CB

DATE: 2013Aug

SCALE: N.T.S.

Source: City of Calgary Standard
Specifications for Landscape
Construction, 2013.

LEGEND & REFERENCES:

-  Sports Field
-  Direction of Surface Drainage
-  Graphic Representation of Contour Line (no scale)

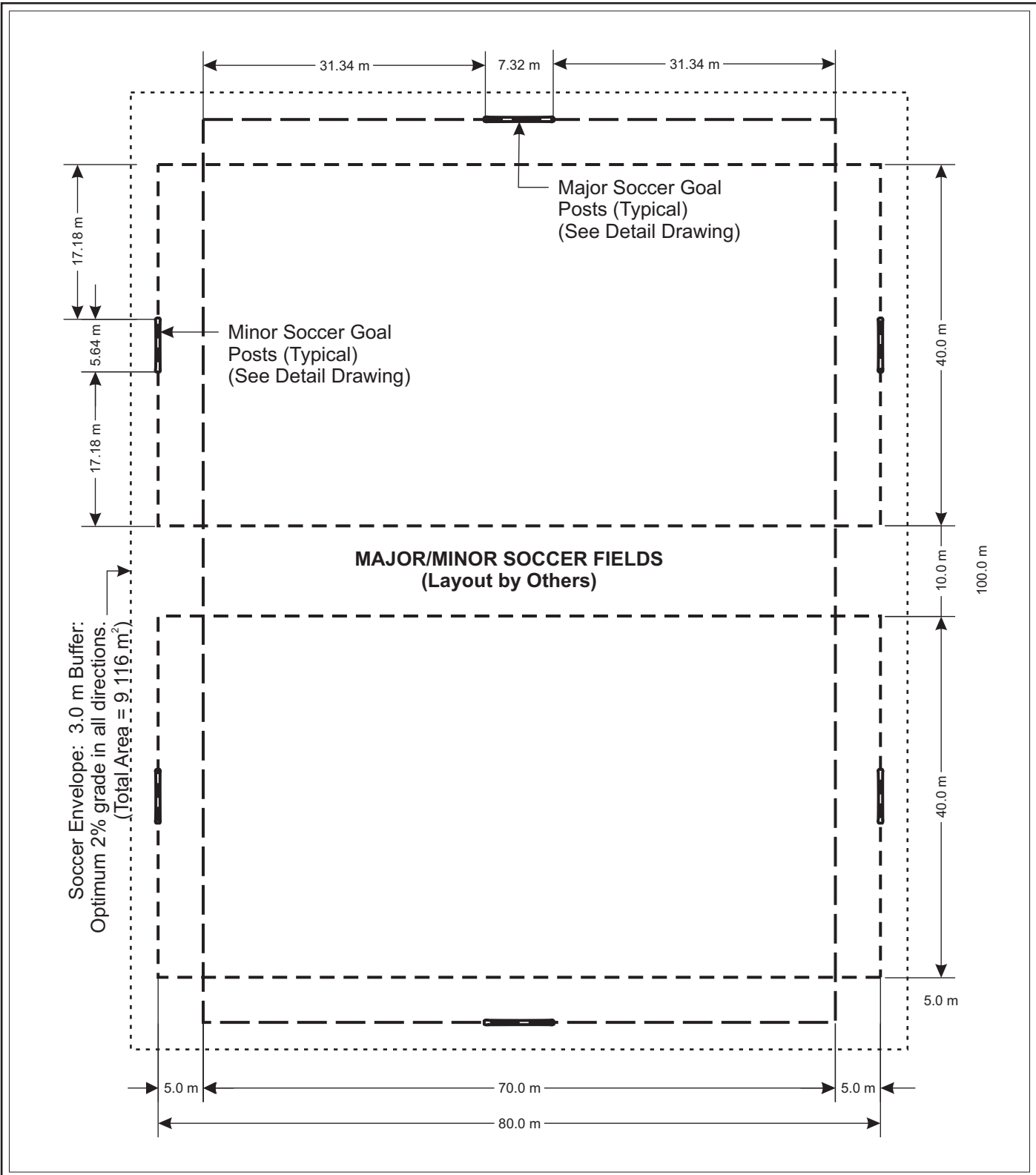

CITY OF CHESTERMERE
Development & Infrastructure Services
Parks Department



PR.0020.11
January, 2015

SHEET TITLE:

Soccer Field
- Combination Major / Minor -

LANDSCAPE STANDARDS & SPECIFICATIONS

SHEET NO:	COCH-LS 3
DRAWN BY:	CB
DATE:	2013Aug
SCALE:	N.T.S.
<i>Units are in metres unless otherwise noted.</i>	
<i>Source: City of Calgary Standard Specifications for Landscape Construction, 2013.</i>	

LEGEND & REFERENCES:

Goal Post locations to be staked by City of Chestermere Development Services - Landscape Technician

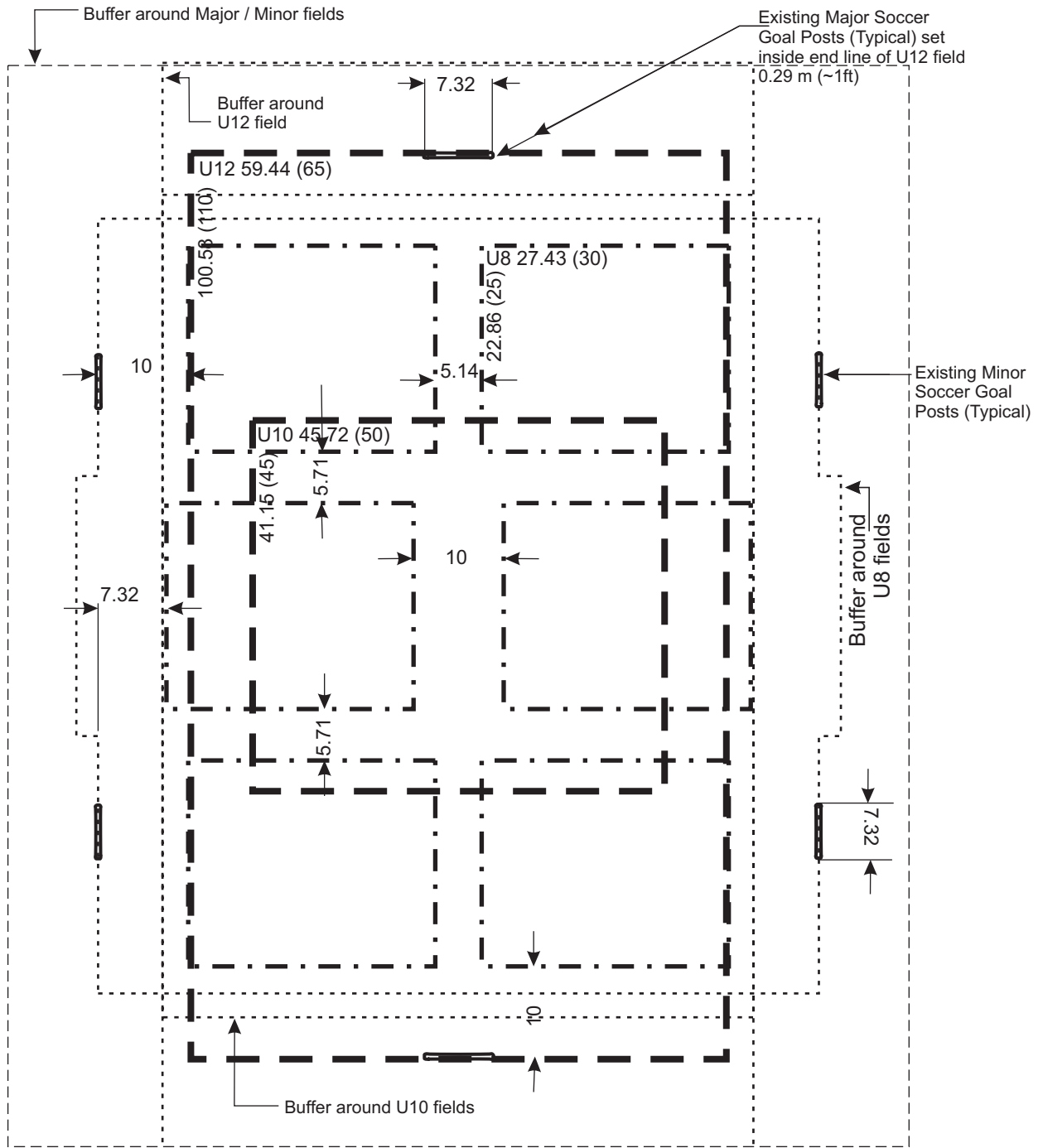

CITY OF CHESTERMERE

Development & Infrastructure Services
Parks Department



PR.0020.11
January, 2015

SHEET TITLE:

Soccer Field
- U12 - U6 Layout -

LANDSCAPE STANDARDS & SPECIFICATIONS

SHEET NO: COCH-LS 4

DRAWN BY: CB

DATE: 2013Aug

SCALE: N.T.S.

Units are in metres unless otherwise noted.

Source: City of Calgary Standard Specifications for Landscape Construction, 2013.

LEGEND & REFERENCES:

1. Dimensions in yards are in brackets.
2. Typical buffers around fields are 10 m behind goal posts and 3.0 m along sidelines.
3. U6 fields are 27.43 x 18.29 m (30 x 20 yd) and layout in the same locations as the U8 fields.

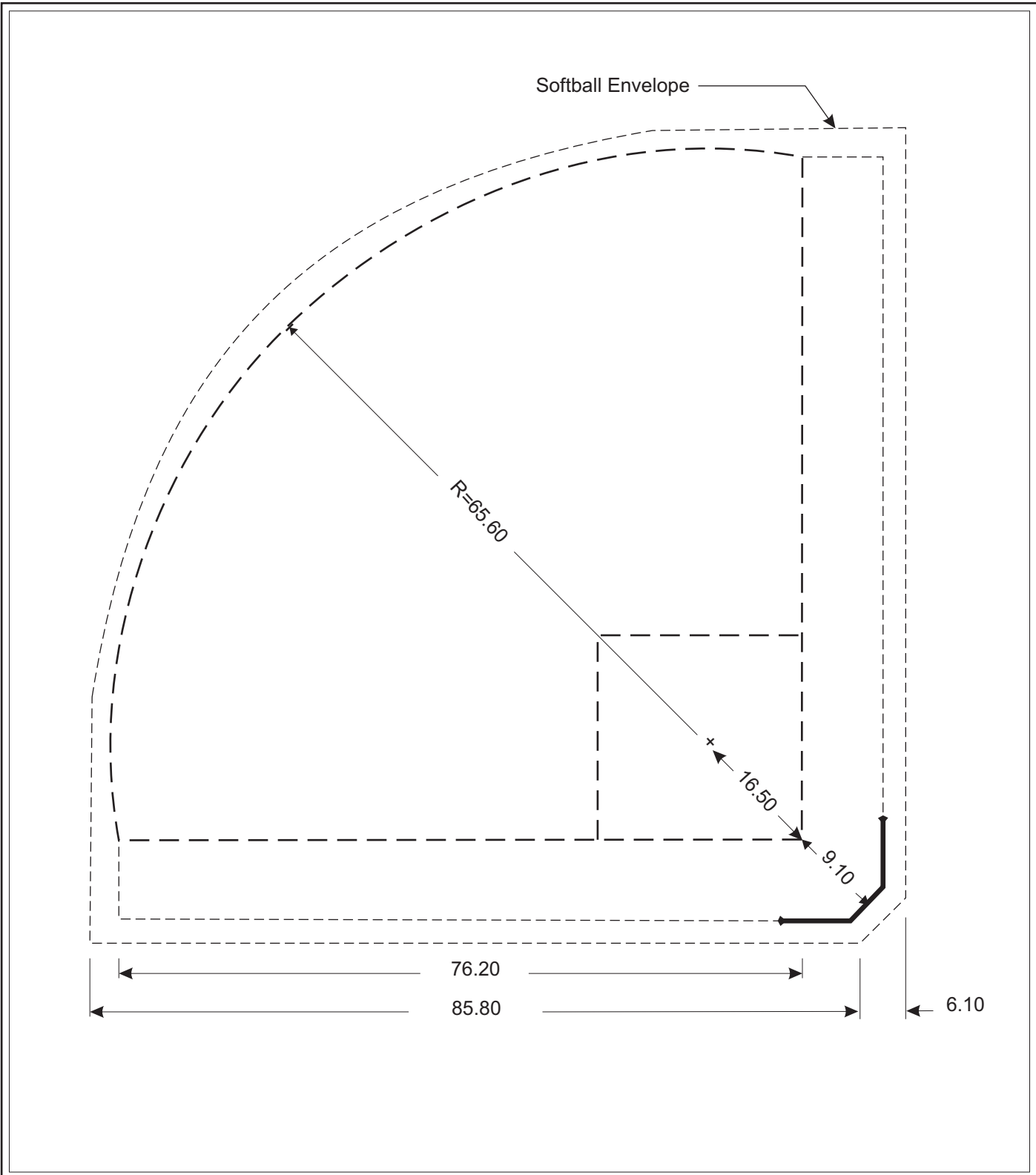

CITY OF CHESTERMERE
 Development & Infrastructure
 Services
 Parks Department



PR.0020.11
 January, 2015

SHEET TITLE:

Softball Diamond
 - 76.2 m -

**LANDSCAPE STANDARDS &
 SPECIFICATIONS**

SHEET NO:	COCH-LS 8
DRAWN BY:	CB
DATE:	2013Aug
SCALE:	N.T.S.
<i>Units are in metres unless otherwise noted.</i>	
<i>Source: City of Calgary Standard Specifications for Landscape Construction, 2013.</i>	

LEGEND & REFERENCES:

Softball Envelope:
 - 3.0 m Buffer;
 - Optimum 2% Grade in all directions; and
 - Total area including buffer equals 7,406 m²

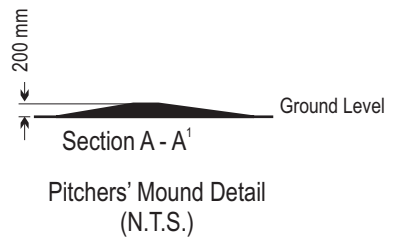
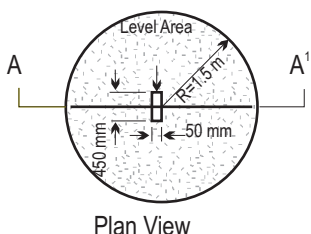
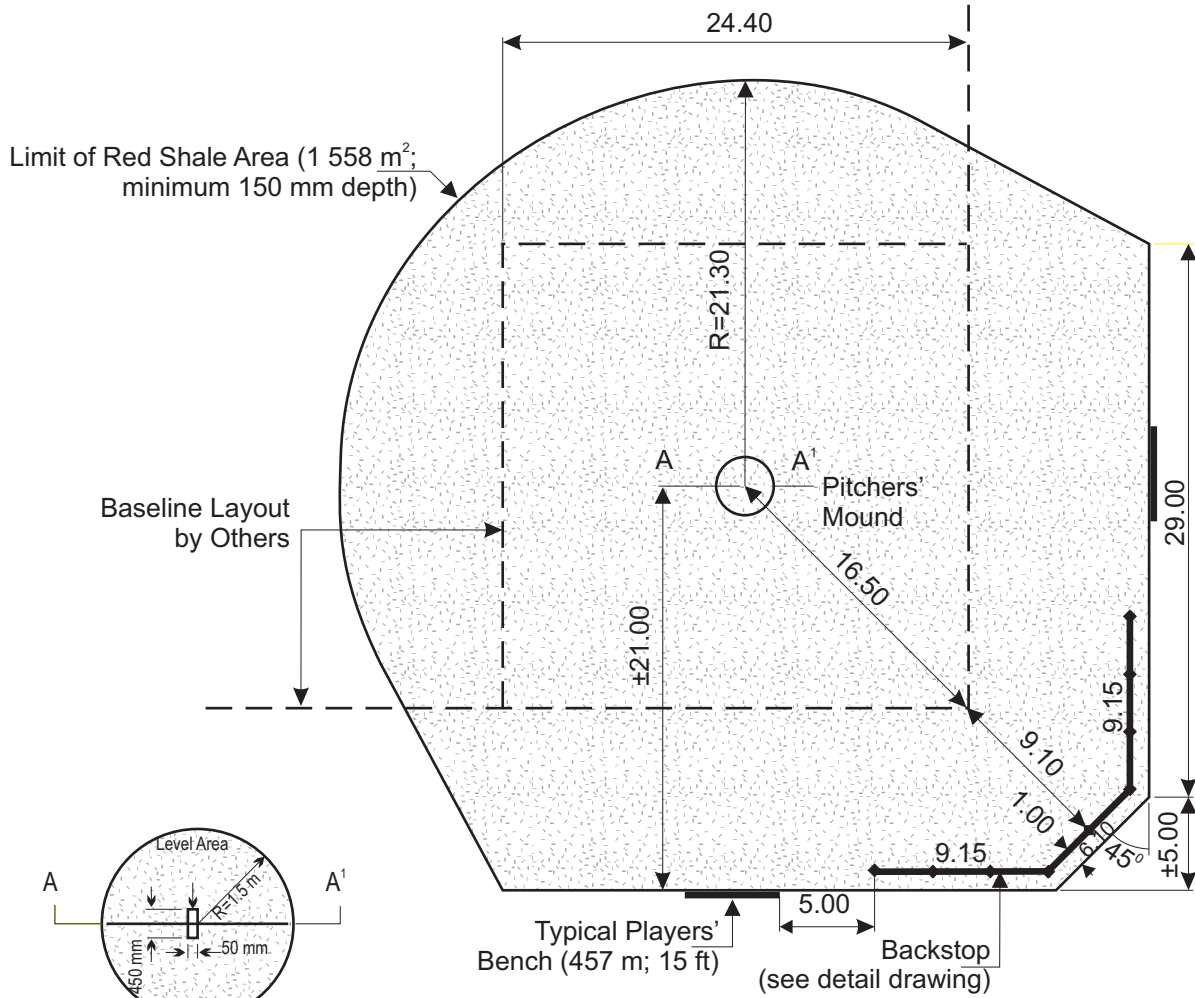

CITY OF CHESTERMERE
 Development & Infrastructure
 Services
 Parks Department



PR.0020.11
 January, 2015

SHEET TITLE:
 Little League Baseball Diamond
 - 76.2 m Infield -

LANDSCAPE STANDARDS & SPECIFICATIONS

SHEET NO:	COCH-LS 9
DRAWN BY:	CB
DATE:	2013Aug
SCALE:	N.T.S.

Units are in metres unless otherwise noted.

Source: City of Calgary Standard Specifications for Landscape Construction, 2013.

LEGEND & REFERENCES:

- Backstop & Red Shale corner locations to be staked by City of Chestermere.

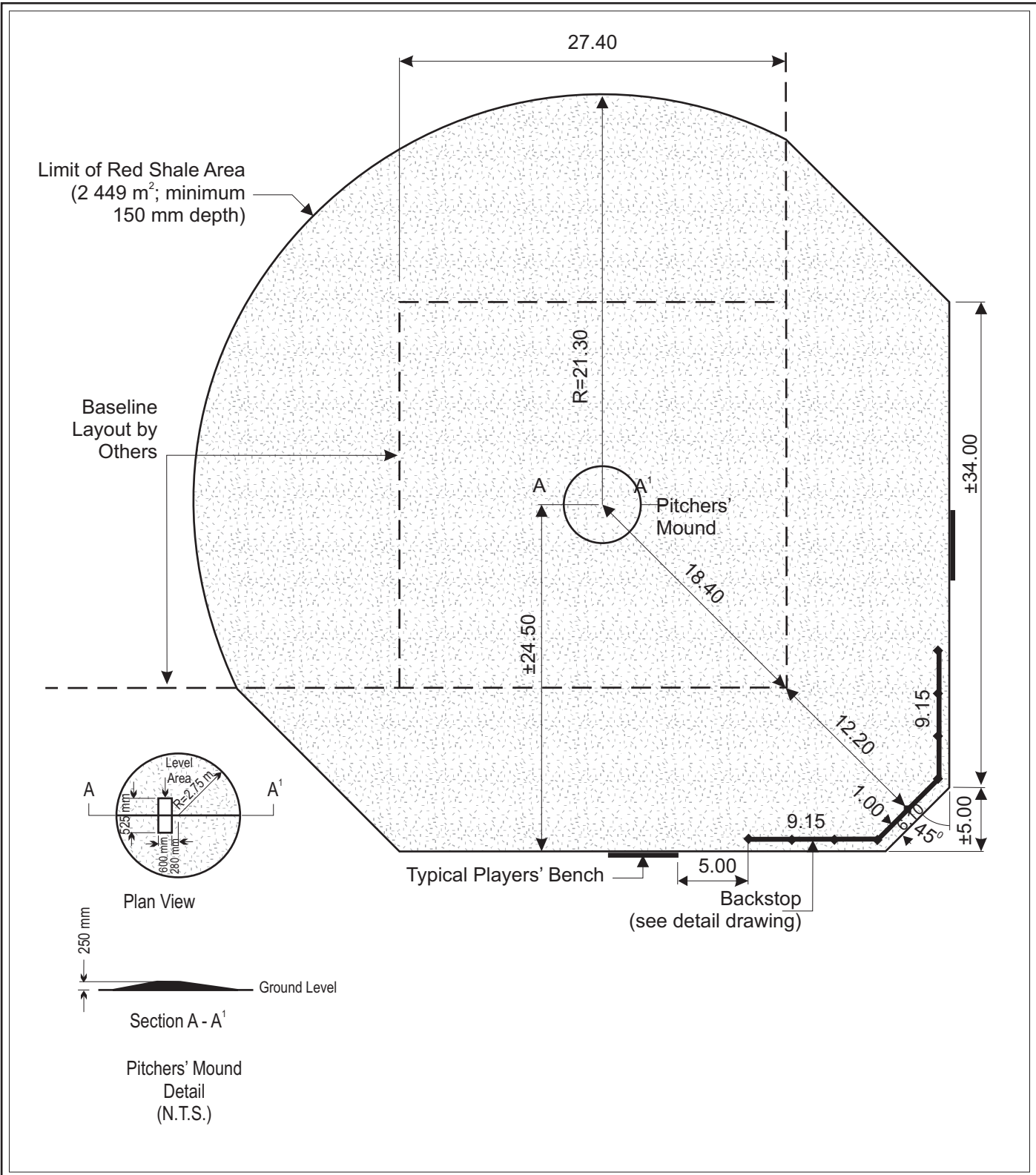

CITY OF CHESTERMERE
 Development & Infrastructure
 Services
 Parks Department



PR.0020.11
 January, 2015

SHEET TITLE:
 Little League Baseball Diamond
 - 91.4 m Infield -

LANDSCAPE STANDARDS & SPECIFICATIONS

SHEET NO:	COCH-LS 10
DRAWN BY:	CB
DATE:	2013Aug
SCALE:	N.T.S.
<i>Units are in metres unless otherwise noted.</i>	
<i>Source: City of Calgary Standard Specifications for Landscape Construction, 2013.</i>	

LEGEND & REFERENCES:

1. Backstop & Red Shale corner locations to be staked by City of Chestermere.

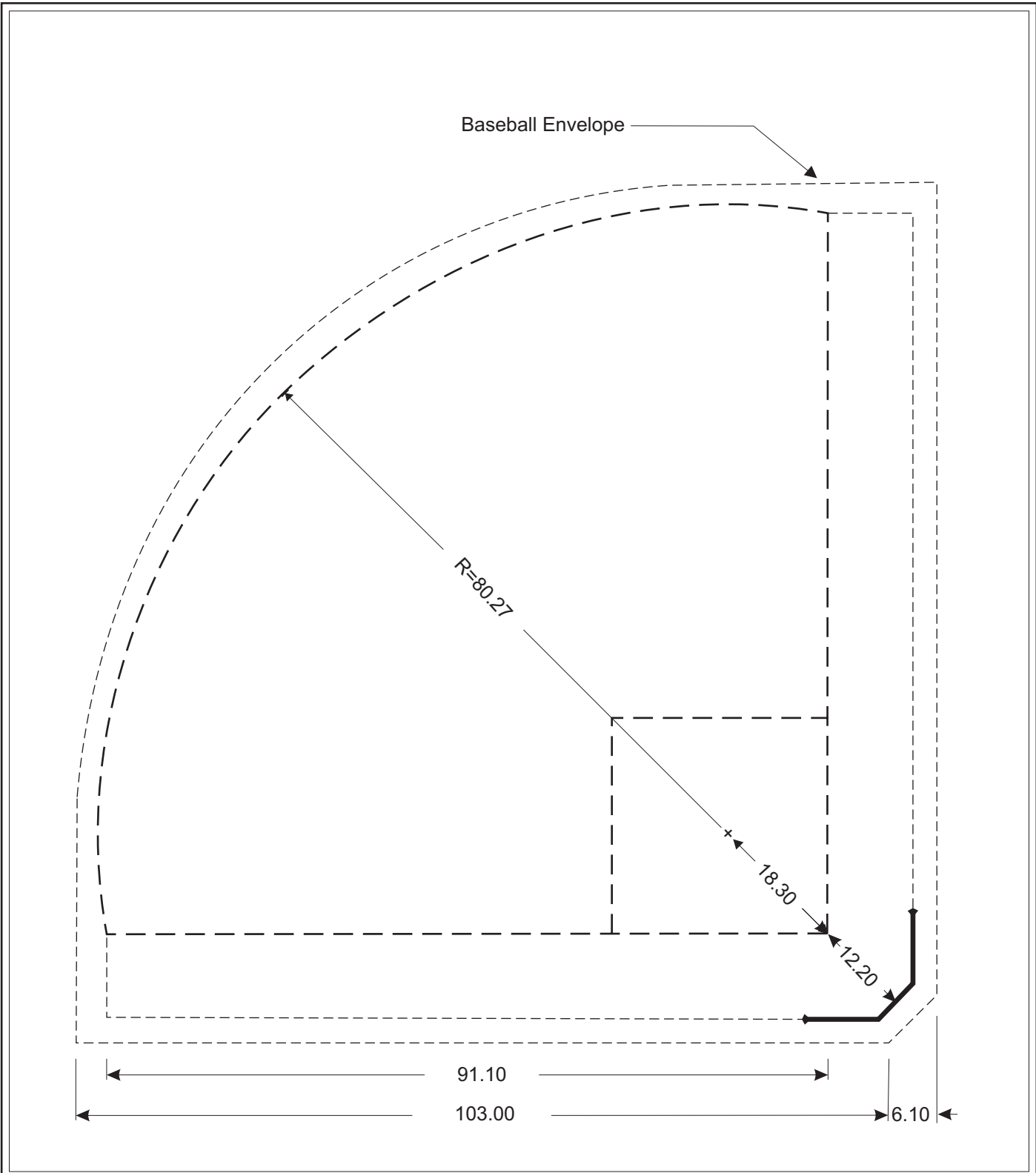

CITY OF CHESTERMERE
 Development & Infrastructure
 Services
 Parks Department



PR.0020.11
 January, 2015

SHEET TITLE:
 Little League Baseball Diamond
 - 91.4 m -

LANDSCAPE STANDARDS & SPECIFICATIONS

SHEET NO:	COCH-LS 11
DRAWN BY:	CB
DATE:	2013Aug
SCALE:	N.T.S.
<i>Units are in metres unless otherwise noted.</i>	
<i>Source: City of Calgary Standard Specifications for Landscape Construction, 2013.</i>	

LEGEND & REFERENCES:

Baseball Envelope:
 - 3.0 m Buffer;
 - Optimum 2% Grade in all directions; and
 - Total area equals 10,394 m²

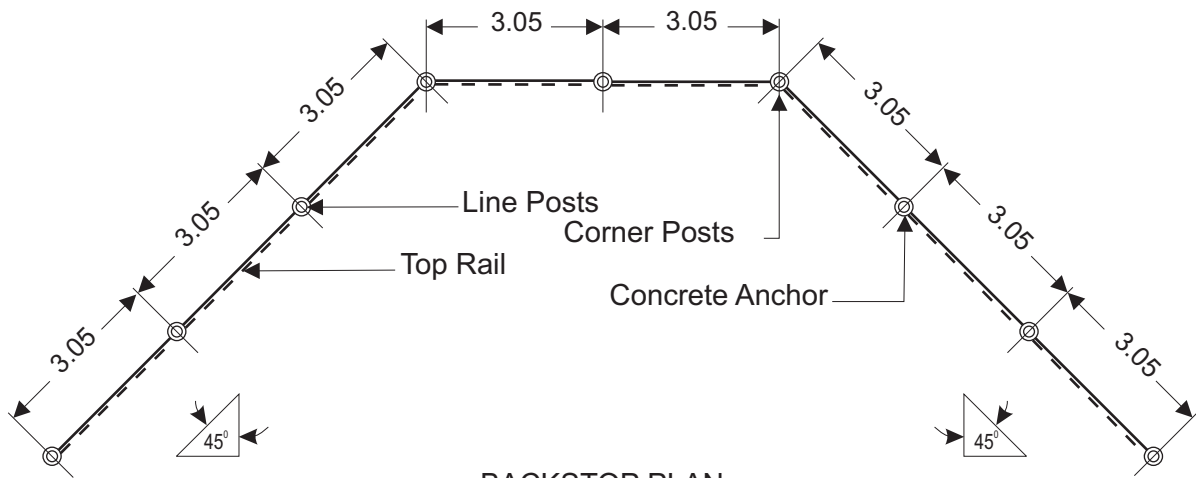

BACKSTOP PLAN

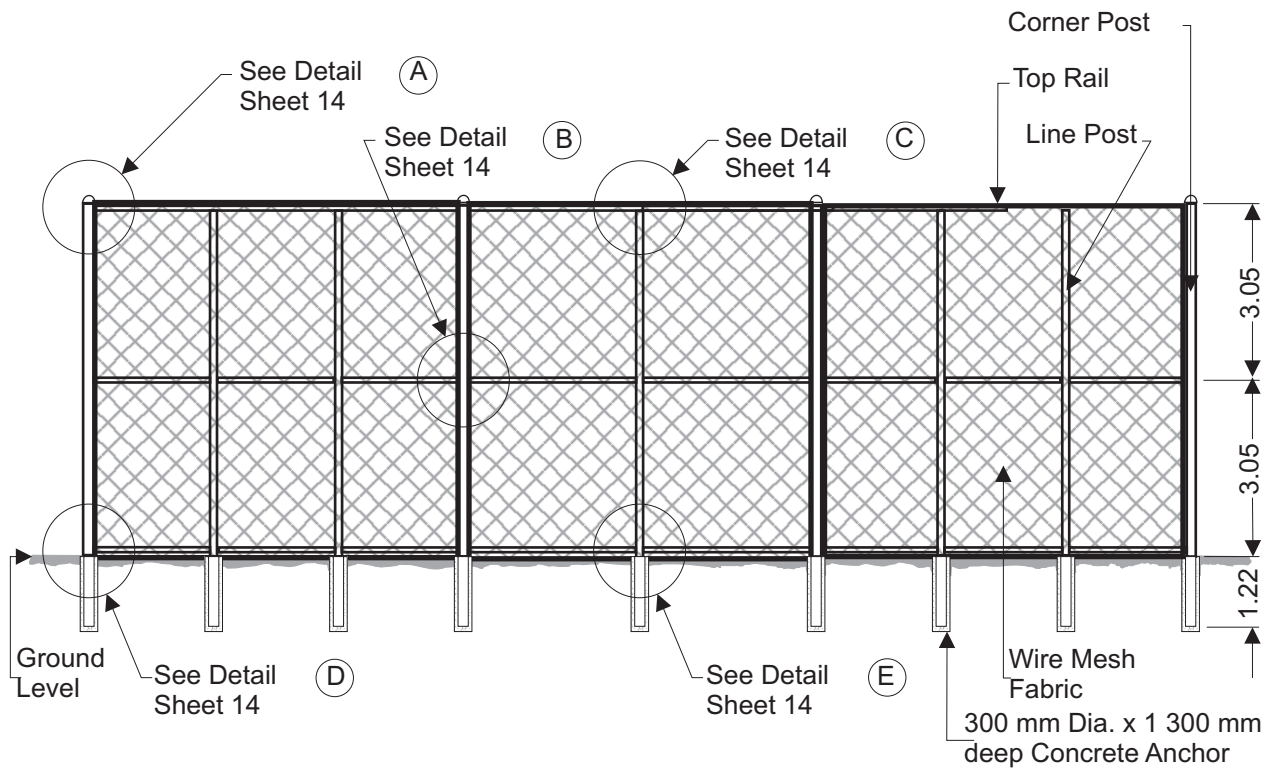

BACKSTOP ELEVATION

CITY OF CHESTERMERE
 Development & Infrastructure
 Services
 Parks Department



PR.0020.11
 January, 2015

SHEET TITLE:
 Baseball Diamond
 - Backstop Details -

**LANDSCAPE STANDARDS &
 SPECIFICATIONS**

SHEET NO:	COCH-LS 12
DRAWN BY:	CB
DATE:	2013Aug
SCALE:	N.T.S.

Units are in metres unless otherwise noted.

Source: City of Calgary Standard Specifications for Landscape Construction, 2013.

LEGEND & REFERENCES:

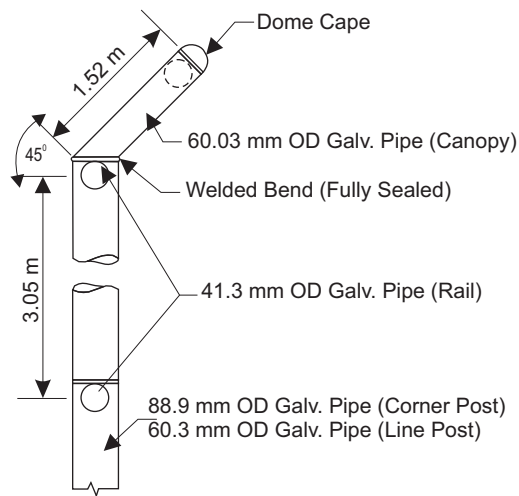

CANOPY DETAIL

NOTE: NO. 6 or NO. 9 Gauge Wire Mesh for Canopy

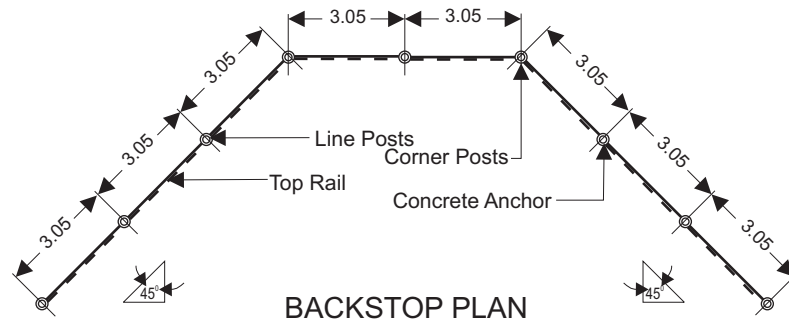

BACKSTOP PLAN

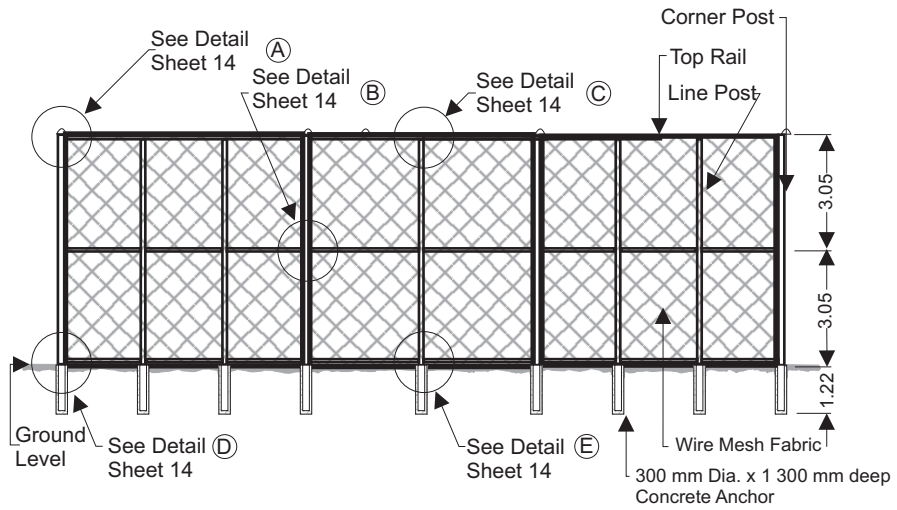

BACKSTOP ELEVATION

CITY OF CHESTERMERE
Development & Infrastructure
Services
Parks Department



PR.0020.11
January, 2015

SHEET TITLE:

Baseball Diamond
- Backstop Details -

LANDSCAPE STANDARDS & SPECIFICATIONS

SHEET NO: COCH-LS 13

DRAWN BY: CB

DATE: 2013Aug

SCALE: N.T.S.

Units are in metres unless otherwise noted.

Source: City of Calgary Standard Specifications for Landscape Construction, 2013.

LEGEND & REFERENCES:

Detail A

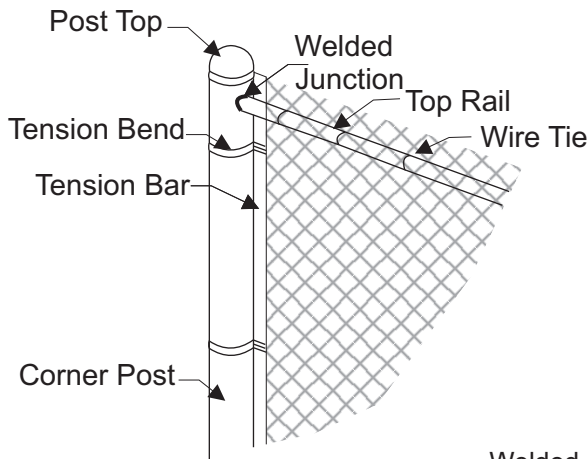

Detail C

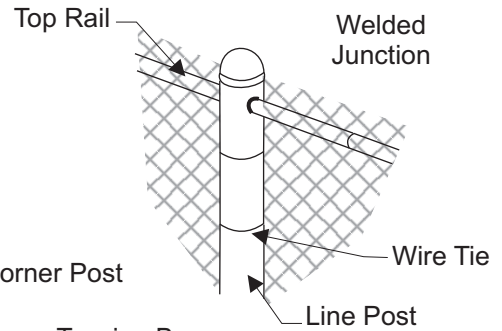

Detail B

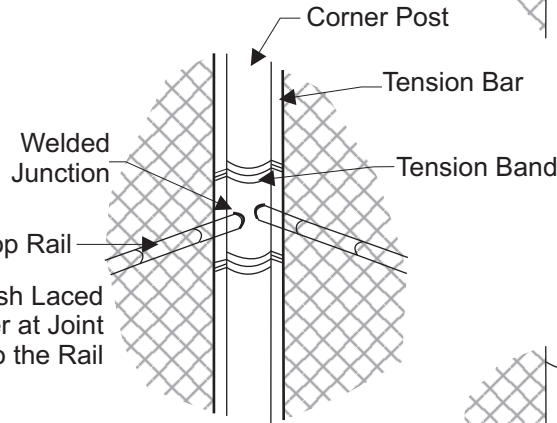

Detail D

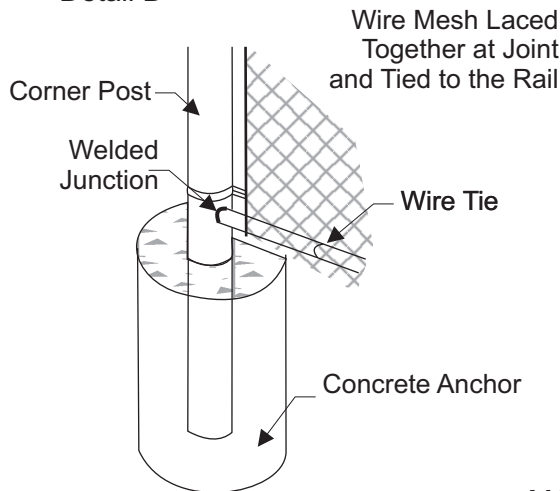

Detail E

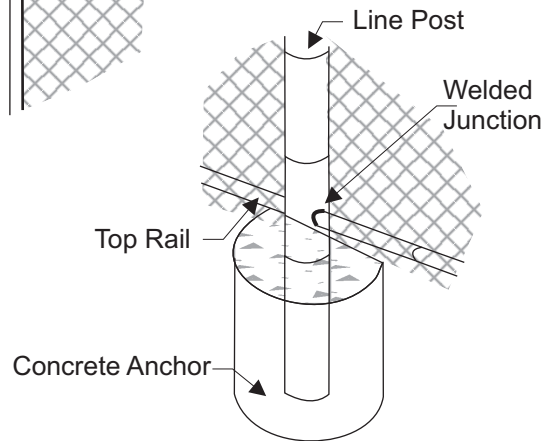

MATERIAL LIST

QTY	SIZE	DESCRIPTION
49 m	3.05 m x 50 mm	No. 6 Gauge Wire Mesh
147 m	41.3 mm OD	Top Rail
4	88.9 mm OD x 7.32 m	Corner Post
5	60.3 mm OD x 7.32 m	Line Post
4	56.9 mm ID	Post Tops
12	3.05 m	Tension Bars
9.07 kg	No. 16 Gauge	Lacing Wire
72	38 mm x 7.9 m	Bolts c/w Locks & Nuts
72	88.9 ID	Tension (offset) Bands

CITY OF CHESTERMERE

Development & Infrastructure
Services
Parks Department



PR.0020.11
January, 2015

SHEET TITLE:

Baseball Diamond
- Backstop Details -

**LANDSCAPE STANDARDS &
SPECIFICATIONS**

SHEET NO: COCH-LS 14

DRAWN BY: CB

DATE: 2013Aug

SCALE: N.T.S.

Units are in metres unless otherwise noted.

*Source: City of Calgary Standard
Specifications for Landscape
Construction, 2013.*

LEGEND & REFERENCES:

Backstop Materials:

38 Welded Junctions - Canopy not included.

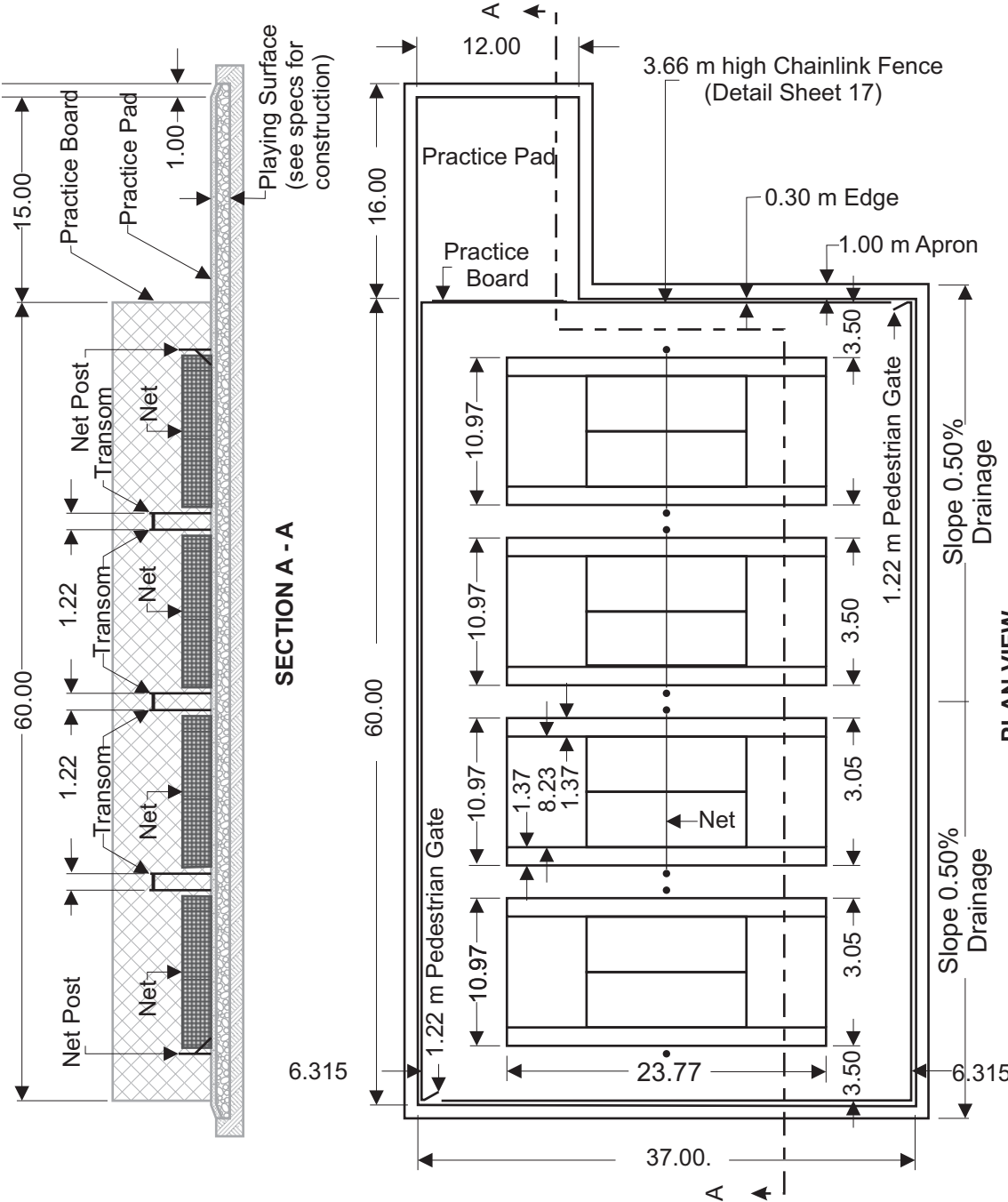

Court Orientation

LEGEND & REFERENCES:

1. Where there is an irrigation mainline with 25 lm of a pedestrian entrance on irrigation turf valve shall be placed at that entrance.
2. Net Post and/or transom located 0.9144 m from edge of court.

SHEET NO:	COCH-LS 15	Units are in metres unless otherwise noted.
DRAWN BY:	CB	
DATE:	2013Dec	
SCALE:	N.T.S.	
Source: City of Calgary Standard Specifications for Landscape Construction, 2013.		

SHEET TITLE:	Tennis Court Construction - Plan & Section View -
PROJECT TITLE:	LANDSCAPE STANDARDS & SPECIFICATIONS

CITY OF CHESTERMERE
Development & Infrastructure Services
Parks Department



PR.0020.11
January, 2015

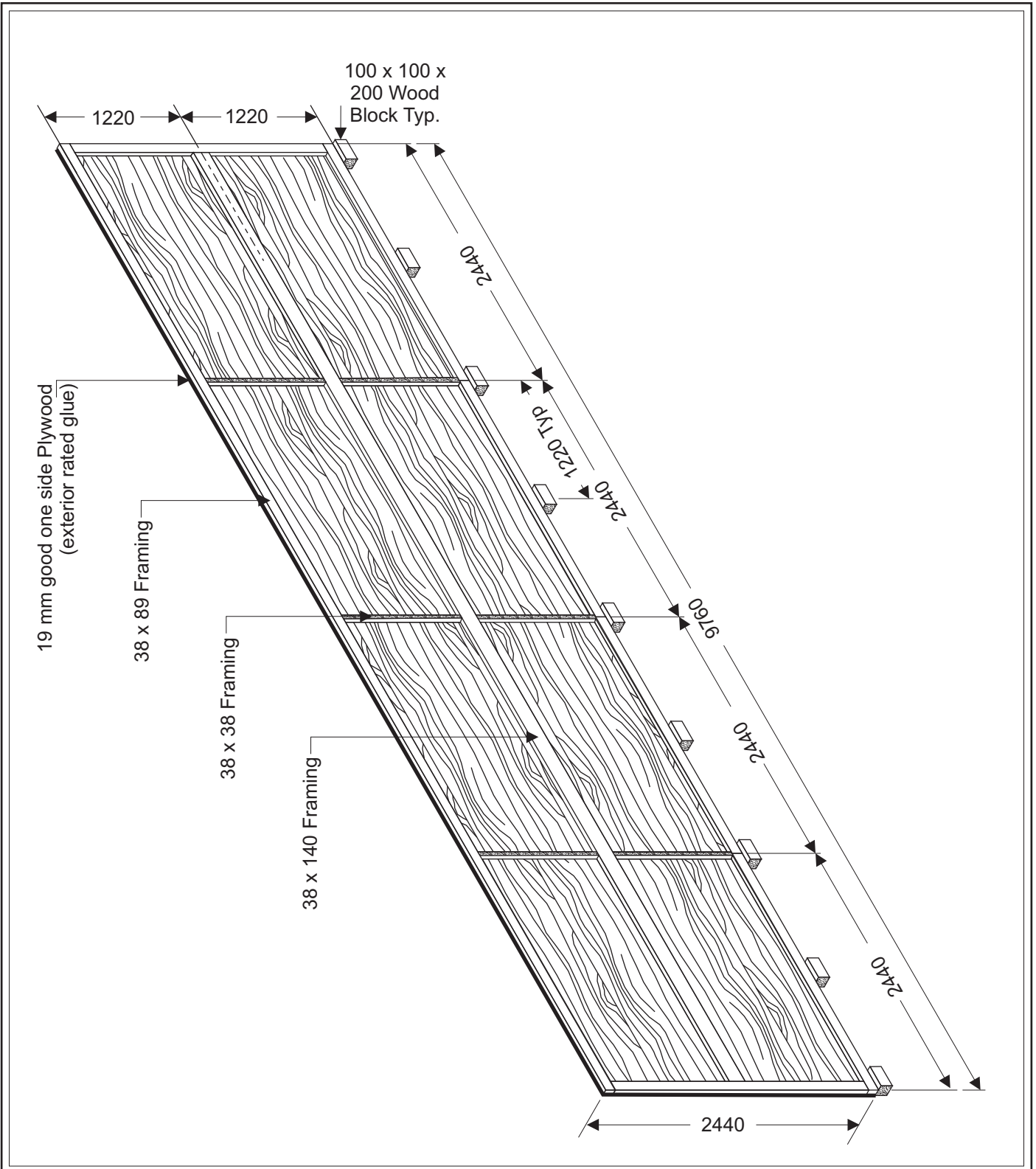

CITY OF CHESTERMERE
 Development & Infrastructure
 Services
 Parks Department



PR.0020.11
 January, 2015

SHEET TITLE:
 Tennis Court Construction
 - Practice Board -

LANDSCAPE STANDARDS & SPECIFICATIONS

SHEET NO:	COCH-LS 16
DRAWN BY:	CB
DATE:	2013Dec
SCALE:	N.T.S.
<i>Units are in millimetres unless otherwise noted.</i>	
<i>Source: City of Calgary Standard Specifications for Landscape Construction, 2013.</i>	

- LEGEND & REFERENCES:**
- Practice Board to be mounted on 89 mm (3 1/2") OD, schedule 40 posts.
 - Practice Board to be mounted 100 mm above court surface for drainage purposes. Provide 100 x 100 x 2000 pressure treated wood blocking @ 1220 mm O.C.
 - Practice Board to receive one coat of primer paint and two coats of "Forest Green" or as otherwise approved.
 - A 75 mm wide White Sighting Line shall be painted on the practice board. This line shall be 1080 mm above and horizontal to the playing surface.

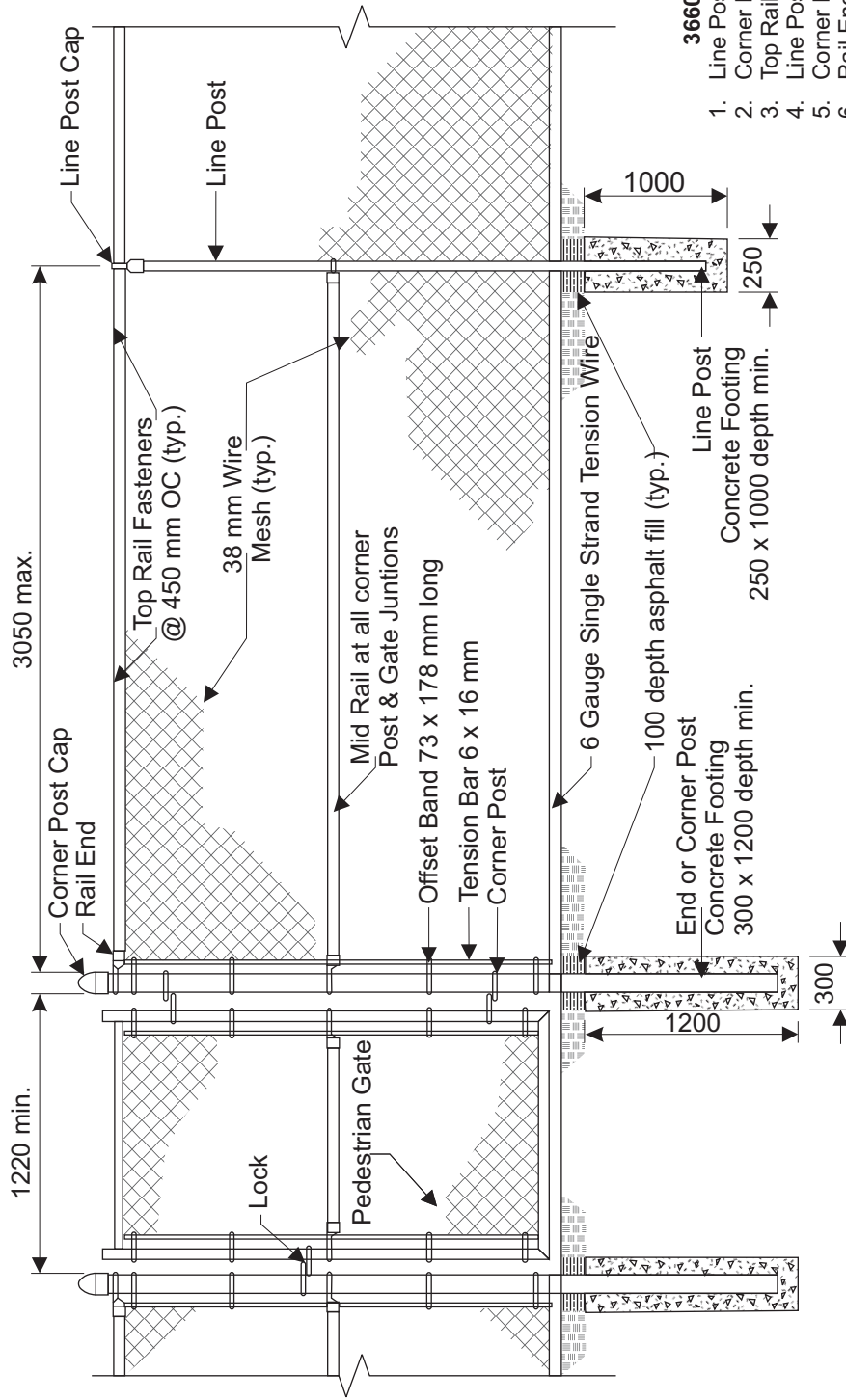

3660 mm Chain Link Fence:

1. Line Posts - 63 x 4500 mm
2. Corner Posts - 89 x 4730 mm
3. Top Rails - 35 x 6700 mm
4. Line Post Caps - 63 mm
5. Corner Post Caps - 89 mm
6. Rail Ends - 35 mm
7. Centre Bands for Line Posts - 63 mm
8. Centre Bands for Corner Posts - 89 mm
9. Offset Bands for Corner Posts - 89 mm
10. Tension Bars - 3660 mm

SHEET NO:	COCH-LS 17	Units are in	millimetres
DRAWN BY:	CB	unless	otherwise
DATE:	2013Dec	noted.	
SCALE:	N.T.S.		

Source: City of Calgary Standard Specifications for Landscape Construction, 2013.

SHEET TITLE:	Tennis Court Construction - Fencing -
PROJECT TITLE:	LANDSCAPE STANDARDS & SPECIFICATIONS

CITY OF CHESTERMERE
Development & Infrastructure
Services
Parks Department

PR.0020.11
January, 2015



LEGEND & REFERENCES:
1. Concrete footings shall be 21 Mpa strength.
2. 3.66 m height chain link mesh.
3. All posts shall be Schedule 40 steel.
4. Mesh size shall be 38 mm; 9 gauge galvanized or coloured vinyl.
5. Mesh to hang no more than 25 mm off surface and no less than 12.5 mm off surface.
6. Mesh on inside of court.
7. 400 - 600 mm ² of asphalt to be removed prior to augering post holes. Repair using asphalt to grade level with surround surface.

Turf (existing grade) to be lower than asphalt apron to allow positive drainage off of courts.

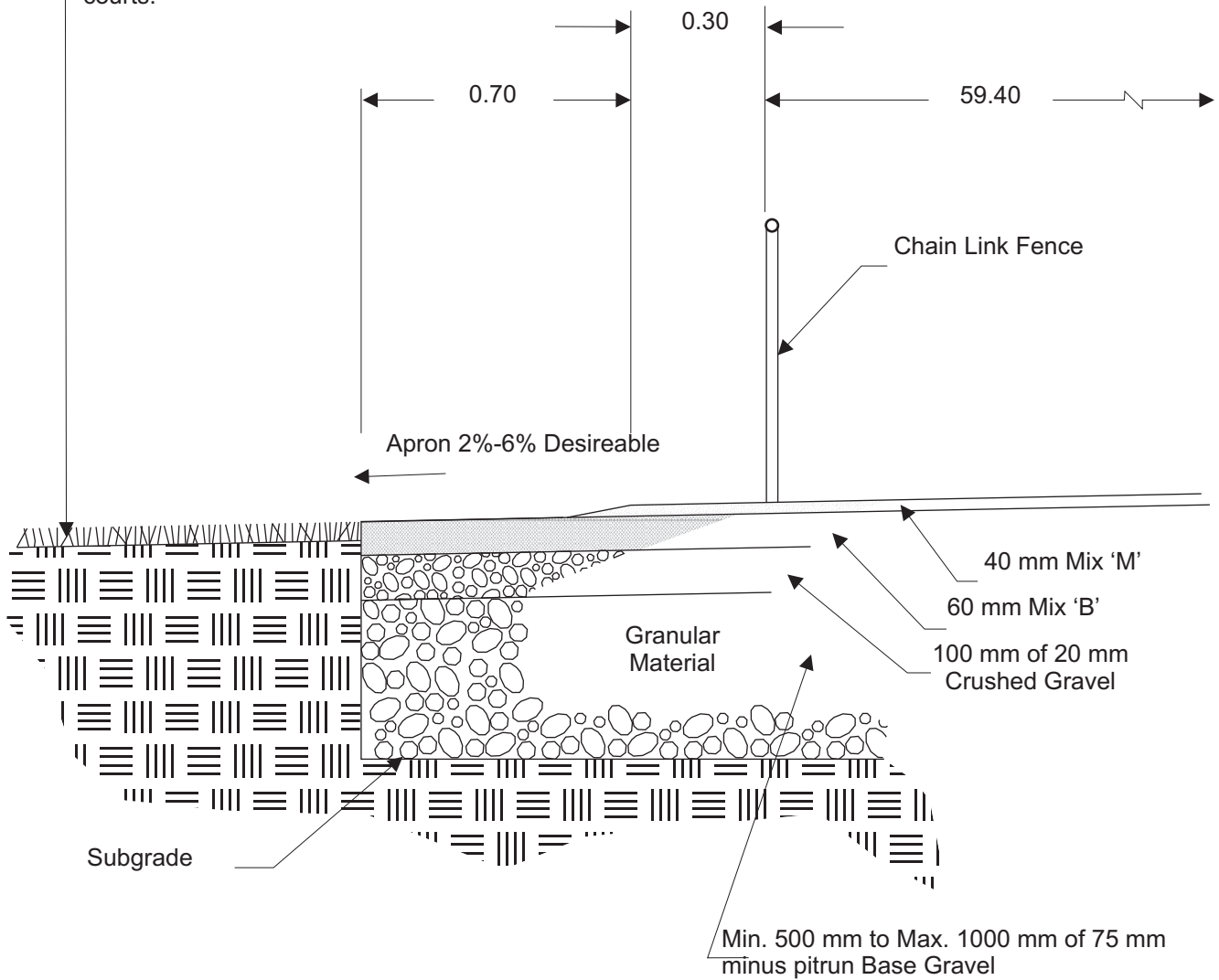

CITY OF CHESTERMERE

Development & Infrastructure
Services
Parks Department



PR.0020.11
January, 2015

SHEET TITLE:

Tennis Court Construction
- Apron Detail -

**LANDSCAPE STANDARDS &
SPECIFICATIONS**

SHEET NO: COCH-LS 18

DRAWN BY: CB

DATE: 2013Dec

SCALE: N.T.S.

*Units are in metres unless
otherwise noted.*

*Source: City of Calgary Standard
Specifications for Landscape
Construction, 2013.*

LEGEND & REFERENCES:

1. See design Information for
Tennis Courts.

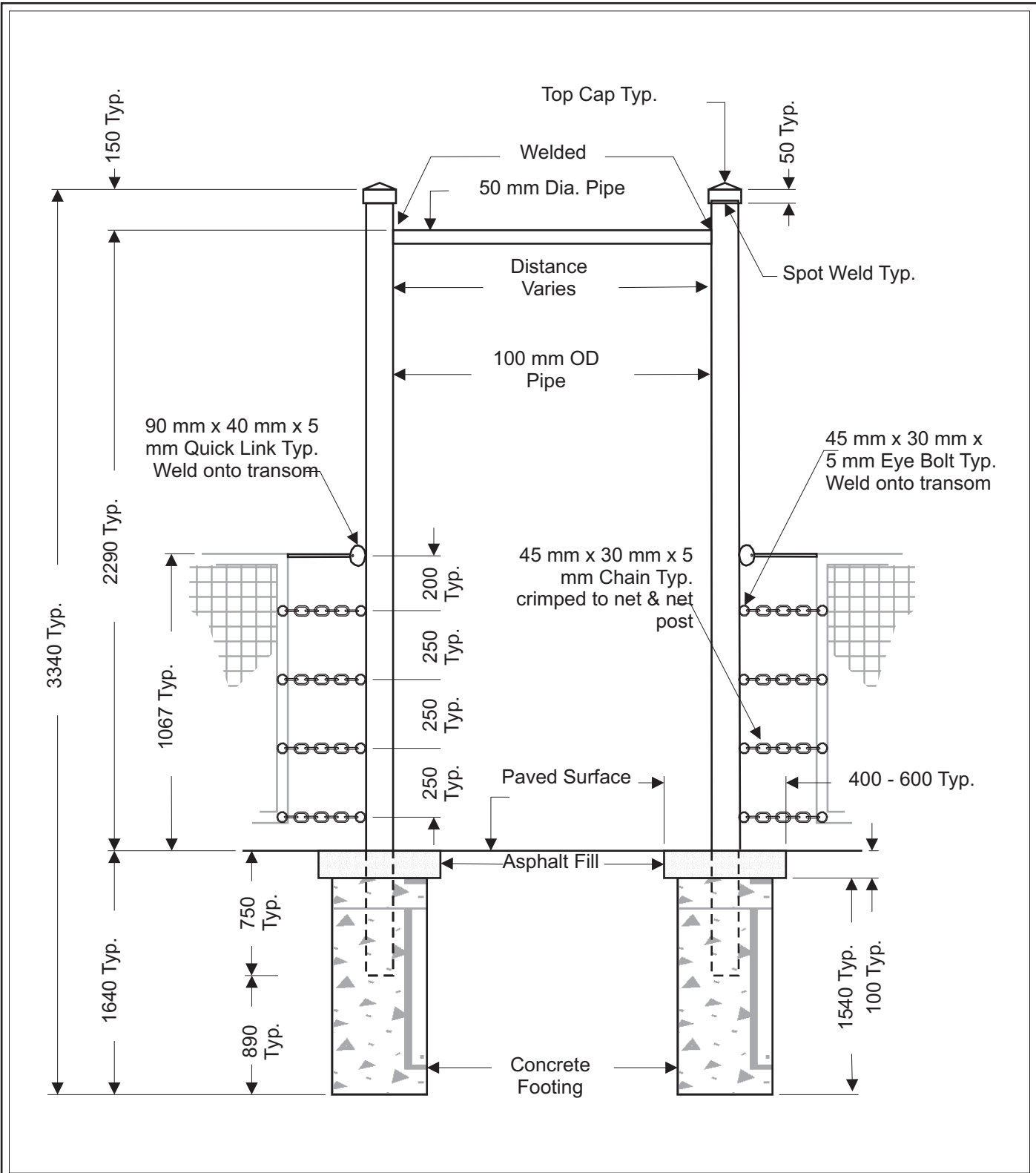

CITY OF CHESTERMERE
 Development & Infrastructure Services
 Parks Department



PR.0020.11
 January, 2015

SHEET TITLE:
 Tennis Court Construction
 - Permanent Transom -

LANDSCAPE STANDARDS & SPECIFICATIONS

SHEET NO:	COCH-LS 19
DRAWN BY:	CB
DATE:	2013Dec
SCALE:	N.T.S.
<i>Units are in millimetres unless otherwise noted.</i>	
<i>Source: City of Calgary Standard Specifications for Landscape Construction, 2013.</i>	

LEGEND & REFERENCES:

- 400 mm - 600 mm square of asphalt to be removed prior to auguring post holes. Repair using asphalt and grade level with surrounding surface.
- All pipe to be Galvanized Schedule 40.

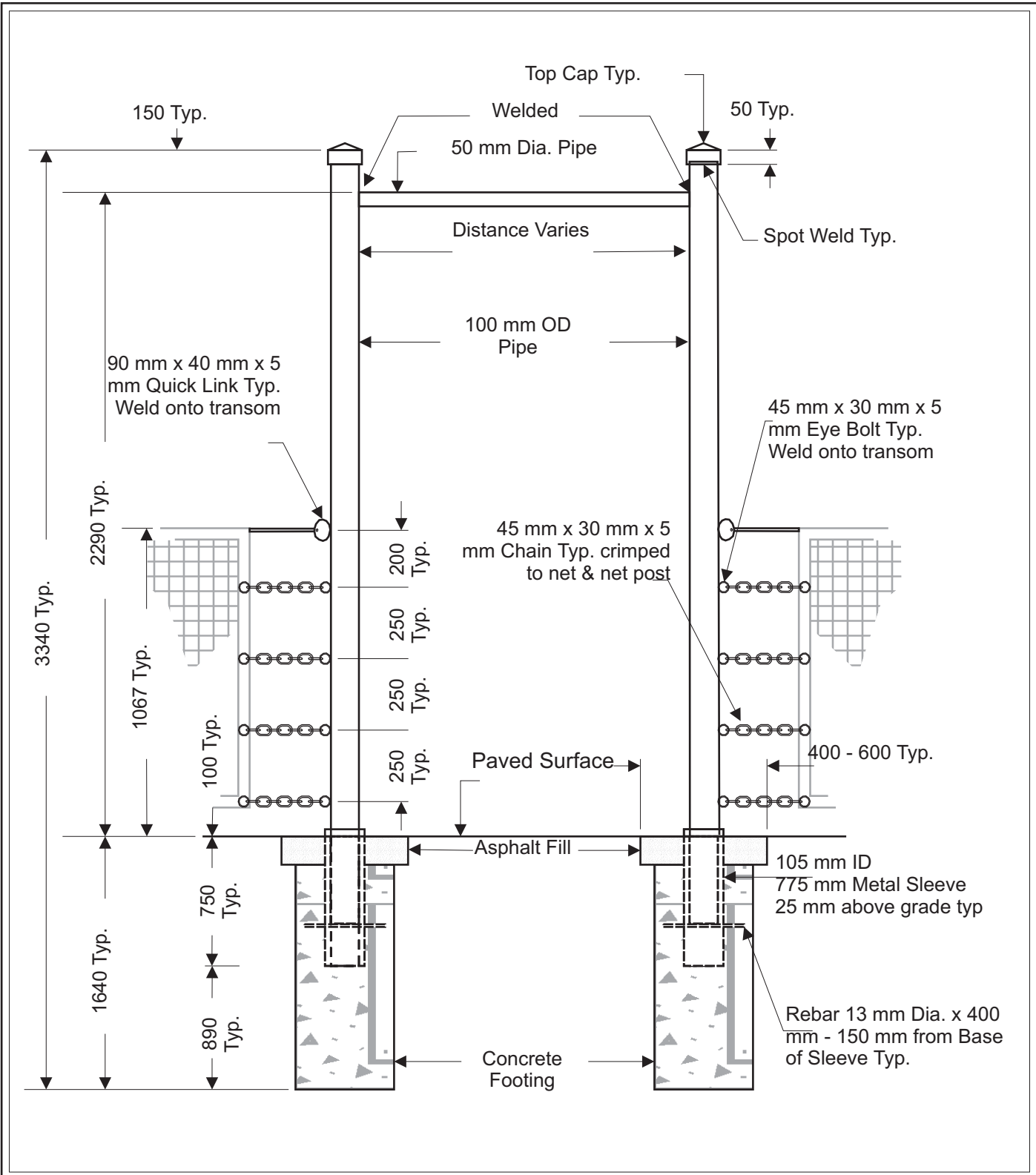

CITY OF CHESTERMERE
 Development & Infrastructure Services
 Parks Department



PR.0020.11
 January, 2015

SHEET TITLE:
 Tennis Court Construction
 - Removable Transom -

LANDSCAPE STANDARDS & SPECIFICATIONS

SHEET NO:	COCH-LS 20
DRAWN BY:	CB
DATE:	2013Dec
SCALE:	N.T.S.
<i>Units are in millimetres unless otherwise noted.</i>	
<i>Source: City of Calgary Standard Specifications for Landscape Construction, 2013.</i>	

LEGEND & REFERENCES:

- 400 mm - 600 mm square of asphalt to be removed prior to auguring post holes. Repair using asphalt and grade level with surrounding surface.
- All pipe to be Galvanized Schedule 40.

REMOVABLE TENNIS NET POST

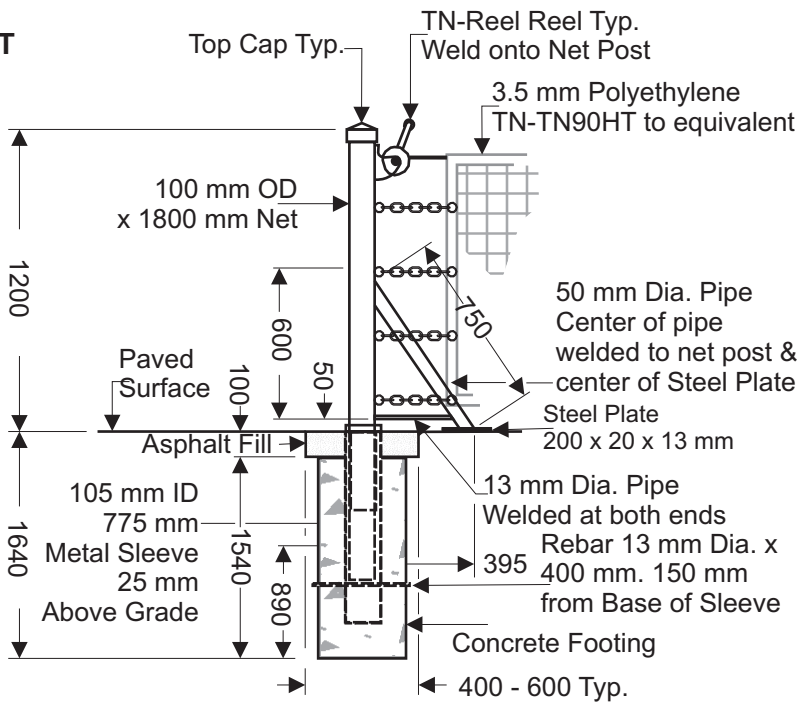

PERMANENT TENNIS NET POST

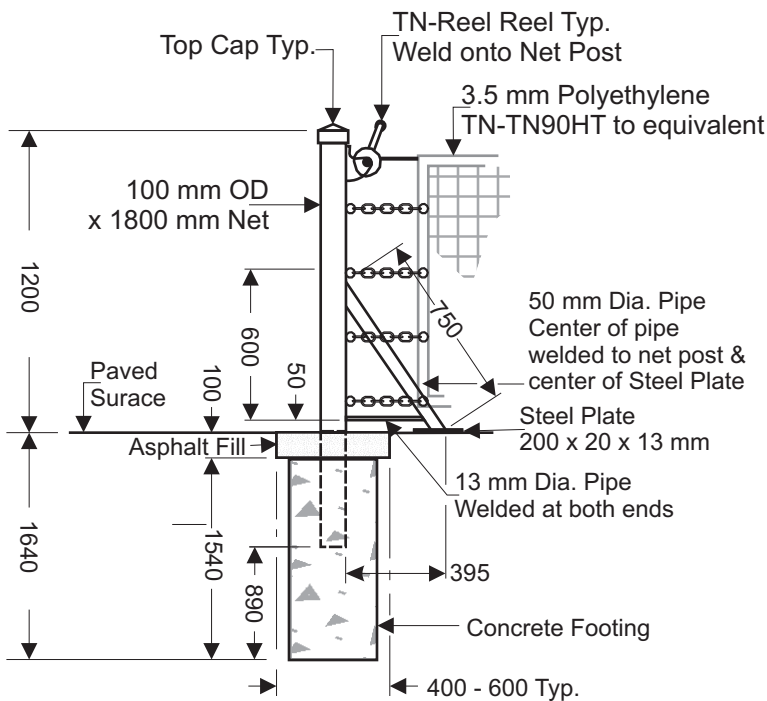

CITY OF CHESTERMERE

Development & Infrastructure
Services
Parks Department



PR.0020.11
January, 2015

SHEET TITLE:

Tennis Court Construction
- Net Post Details -

LANDSCAPE STANDARDS &
SPECIFICATIONS

SHEET NO: COCH-LS 21

DRAWN BY: CB

DATE: 2013Dec

SCALE: N.T.S.

*Units are in millimetres unless
otherwise noted.*

*Source: City of Calgary Standard
Specifications for Landscape
Construction, 2013.*

LEGEND & REFERENCES:

1. 400 mm - 600 mm square of asphalt to be removed prior to auguring post holes. Repair using asphalt and grade level with surrounding surface.
2. All pipe to be Galvanized Schedule 40.
3. Permanent system includes Post Top Caps as approved by Chestermere Parks.
4. Removable system includes Post Top Caps & Covers required to seal sleeves when posts are removed as approved by Chestermere parks.

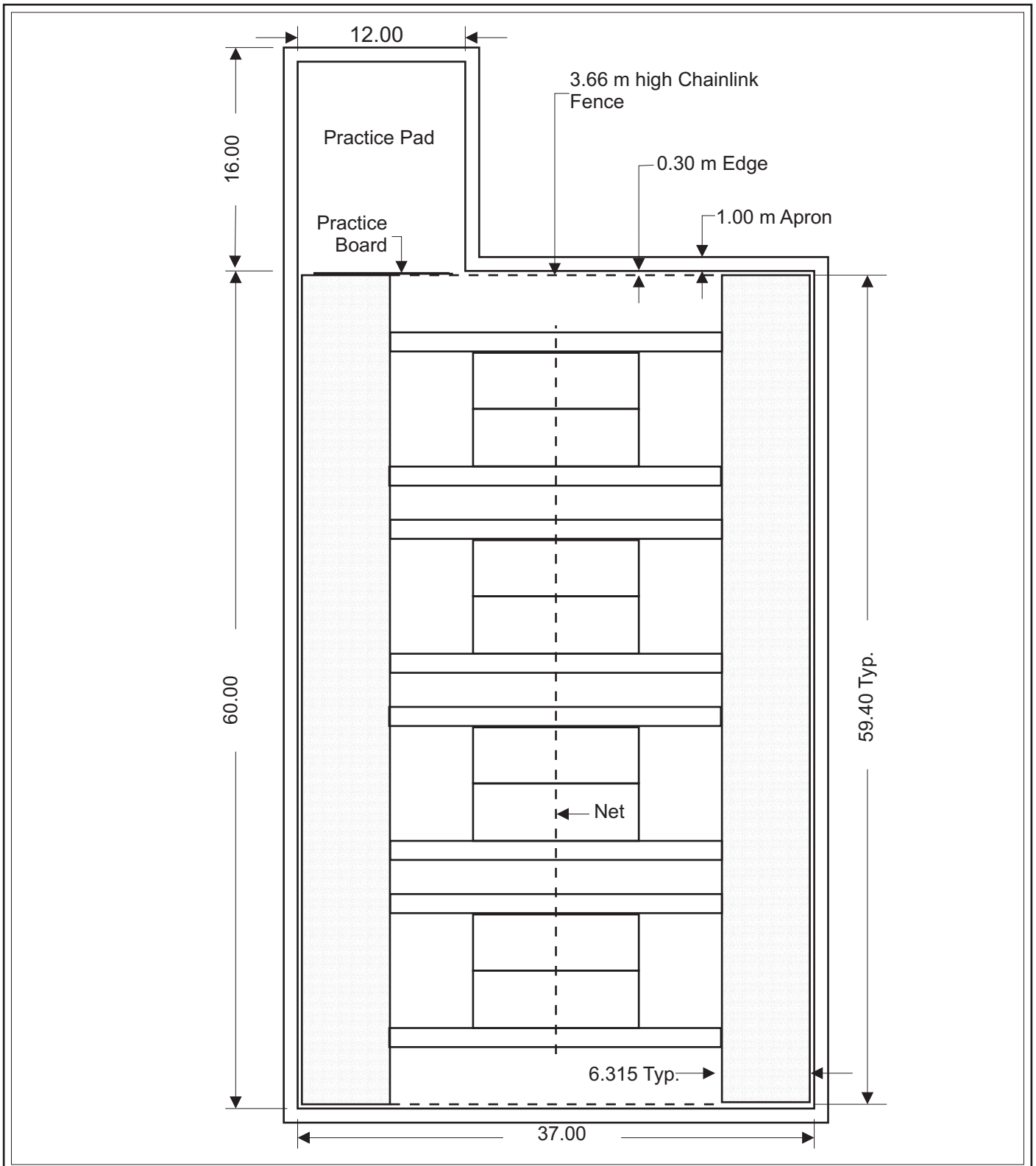

CITY OF CHESTERMERE
 Development & Infrastructure
 Services
 Parks Department



PR.0020.11
 January, 2015

SHEET TITLE:
 Tennis Court Construction
 - Surface Repair Schedule 1 -

LANDSCAPE STANDARDS & SPECIFICATIONS

SHEET NO:	COCH-LS 22
DRAWN BY:	CB
DATE:	2013Dec
SCALE:	N.T.S.
<i>Units are in metres unless otherwise noted.</i>	
<i>Source: City of Calgary Standard Specifications for Landscape Construction, 2013.</i>	

LEGEND & REFERENCES:

 Back Space shown

Colour failure anywhere on back space. Recolour the entire affected area.

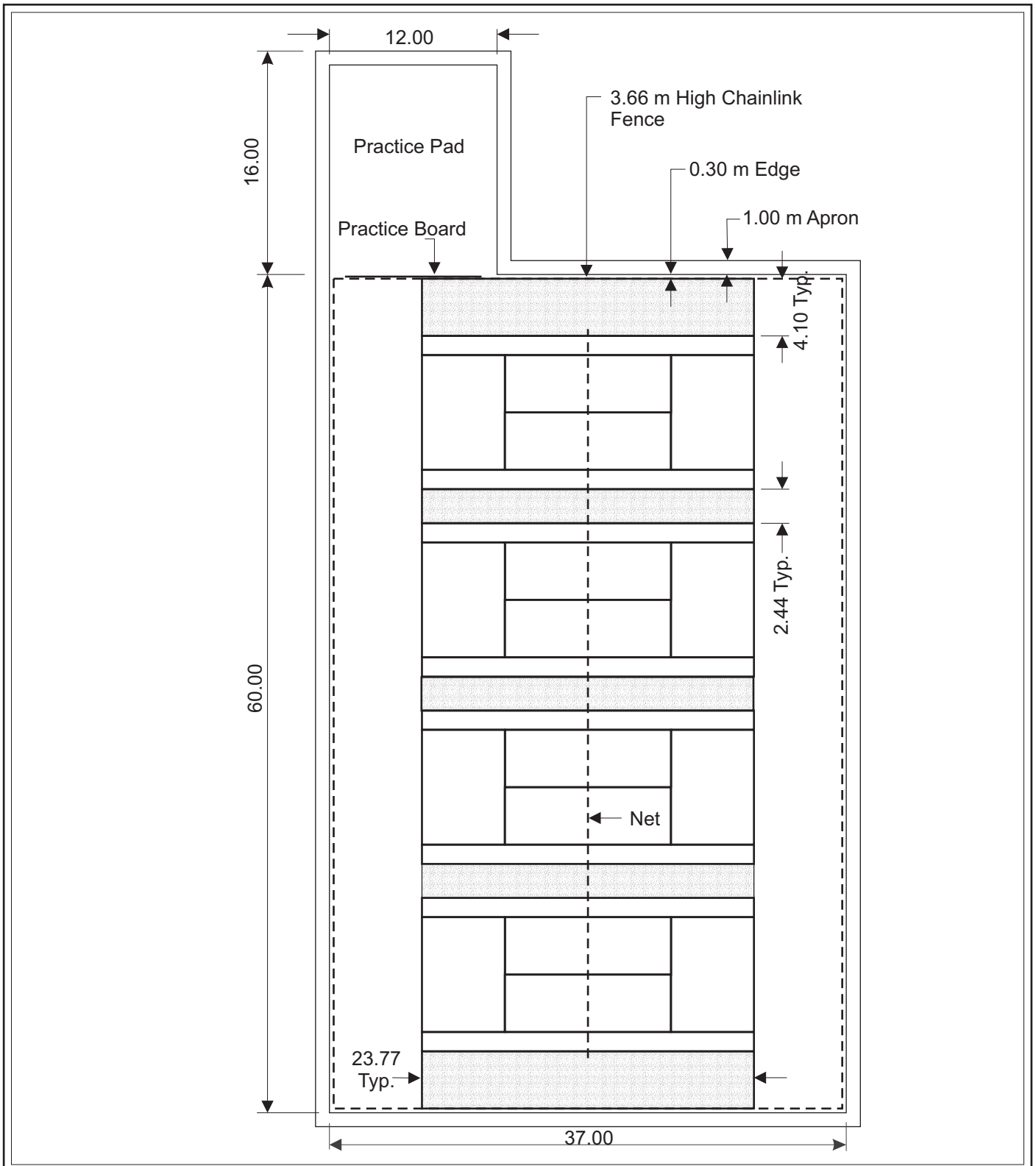

CITY OF CHESTERMERE
 Development & Infrastructure Services
 Parks Department



PR.0020.11
 January, 2015

SHEET TITLE:

Tennis Court Construction
 - Surface Repair Schedule 2 -

LANDSCAPE STANDARDS & SPECIFICATIONS

SHEET NO:	COCH-LS 23
DRAWN BY:	CB
DATE:	2013Dec
SCALE:	N.T.S.

Units are in metres unless otherwise noted.

Source: City of Calgary Standard Specifications for Landscape Construction, 2013.

LEGEND & REFERENCES:

 Side Court Space or between Court Space

Colour failure anywhere on side court space or between court space - recolour the entire affected area.

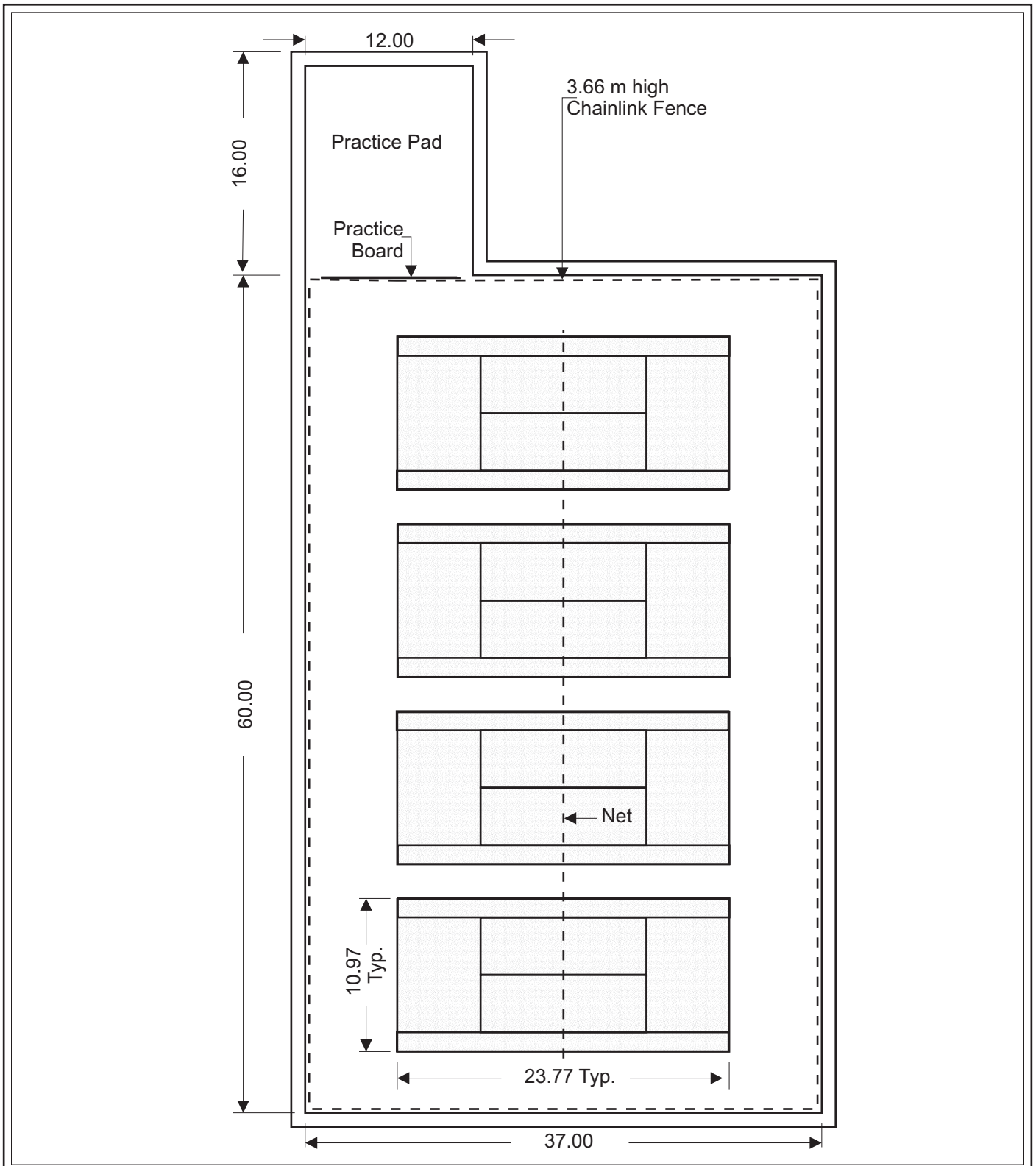

CITY OF CHESTERMERE
 Development & Infrastructure
 Services
 Parks Department



PR.0020.11
 January, 2015

SHEET TITLE:
 Tennis Court Construction
 - Surface Repair Schedule 3 -

LANDSCAPE STANDARDS & SPECIFICATIONS

SHEET NO:	COCH-LS 24
DRAWN BY:	CB
DATE:	2013Dec
SCALE:	N.T.S.

Units are in metres unless otherwise noted.

Source: City of Calgary Standard Specifications for Landscape Construction, 2013.

LEGEND & REFERENCES:

 Back Space

Colour failure anywhere on back space - recolour the entire affected area.

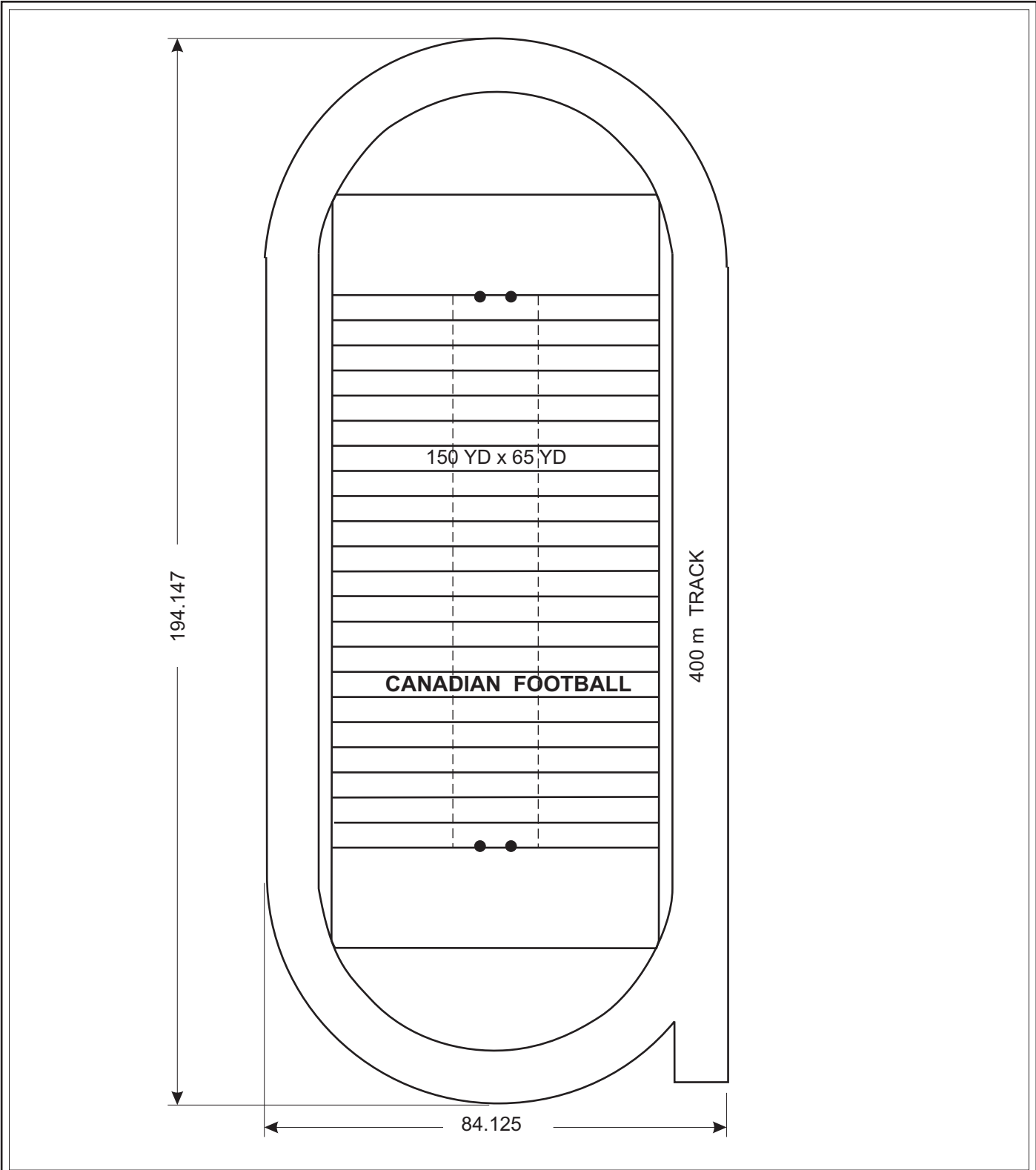

CITY OF CHESTERMERE
 Development & Infrastructure
 Services
 Parks Department



PR.0020.11
 January, 2015

SHEET TITLE:
 Track and Football Field
 Construction
 - 400 m -

**LANDSCAPE STANDARDS &
 SPECIFICATIONS**

SHEET NO:	COCH-LS 25
DRAWN BY:	CB
DATE:	2013Aug
SCALE:	N.T.S.
<i>Units are in metric unless otherwise noted.</i>	
<i>Source: City of Calgary Standard Specifications for Landscape Construction, 2013.</i>	

LEGEND & REFERENCES:

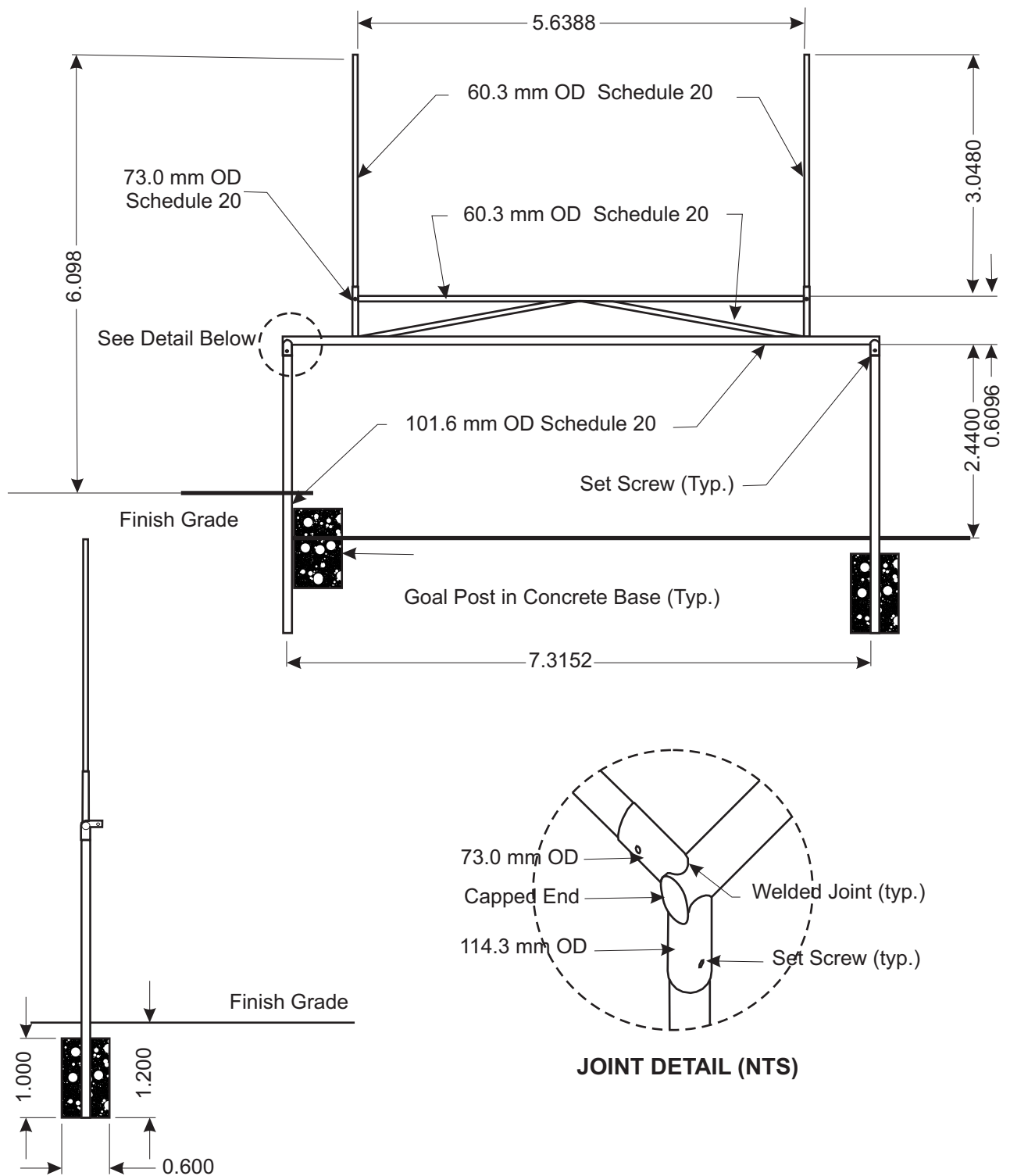

CITY OF CHESTERMERE
 Development & Infrastructure
 Services
 Parks Department



PR.0020.11
 January, 2015

SHEET TITLE:
 Soccer / Rugby or Football
 Combo
 - Goal Posts -

**LANDSCAPE STANDARDS &
 SPECIFICATIONS**

SHEET NO:	COCH-LS 26
DRAWN BY:	CB
DATE:	2013Aug
SCALE:	N.T.S.
<i>Units are in metres unless otherwise noted.</i>	
<i>Source: City of Calgary Standard Specifications for Landscape Construction, 2013.</i>	

LEGEND & REFERENCES:

Combination goals are required, this specification is an example of Football and all will be approved individually.

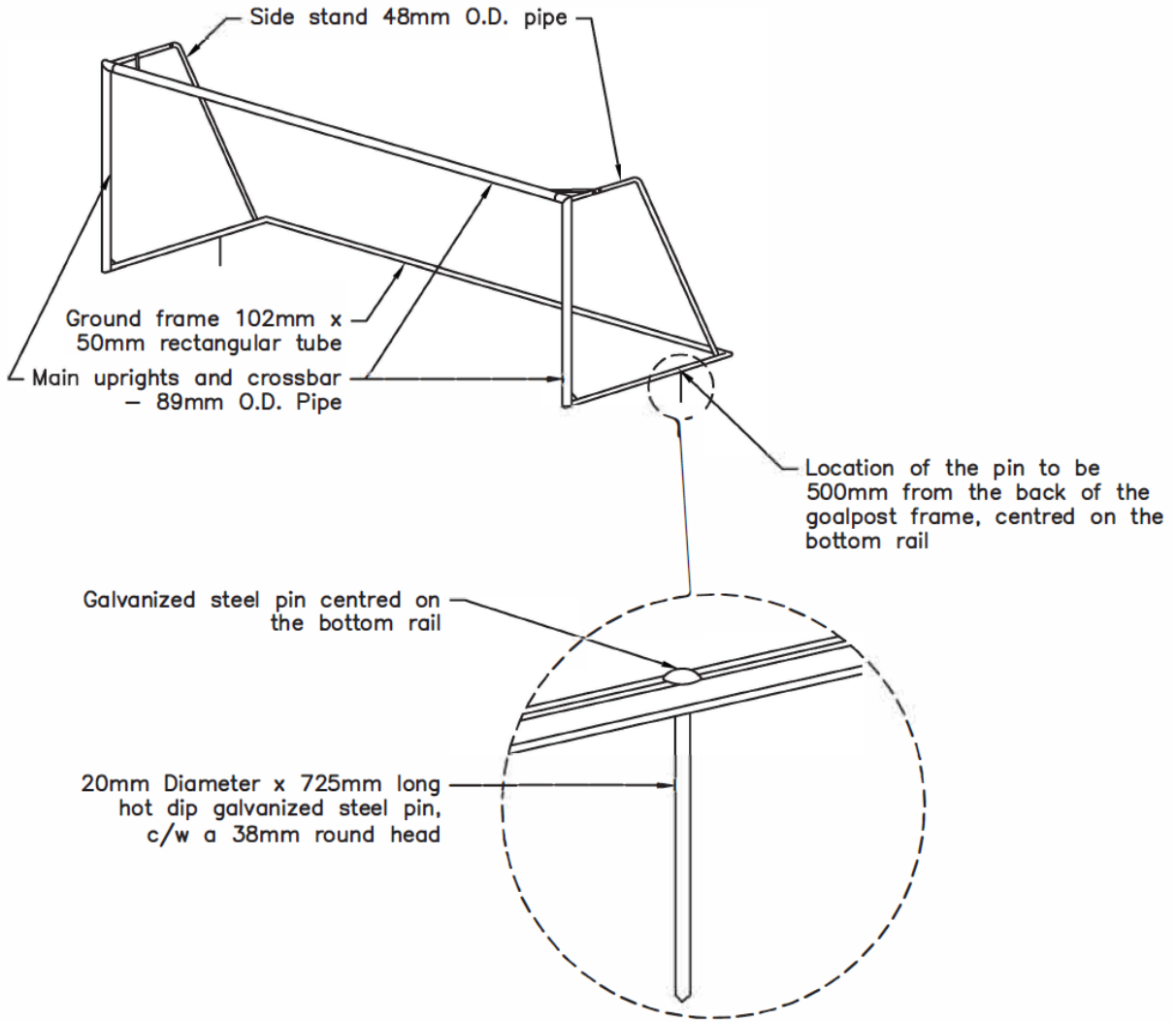

CITY OF CHESTERMERE
 Development & Infrastructure
 Services
 Parks Department



PR.0020.11
 April 2026

SHEET TITLE:
 Portable Soccer Goal

LANDSCAPE STANDARDS & SPECIFICATIONS

SHEET NO:	COCH-LS-26A
DRAWN BY:	TCP
DATE:	2010/11/25
SCALE:	N.T.S.
All dimensions are in millimetres unless otherwise specified.	
Source: City of Calgary Standard Specifications for Parks and Open Spaces 2026.	

LEGEND & REFERENCES:

- All goal pipe shall be powder coated steel.

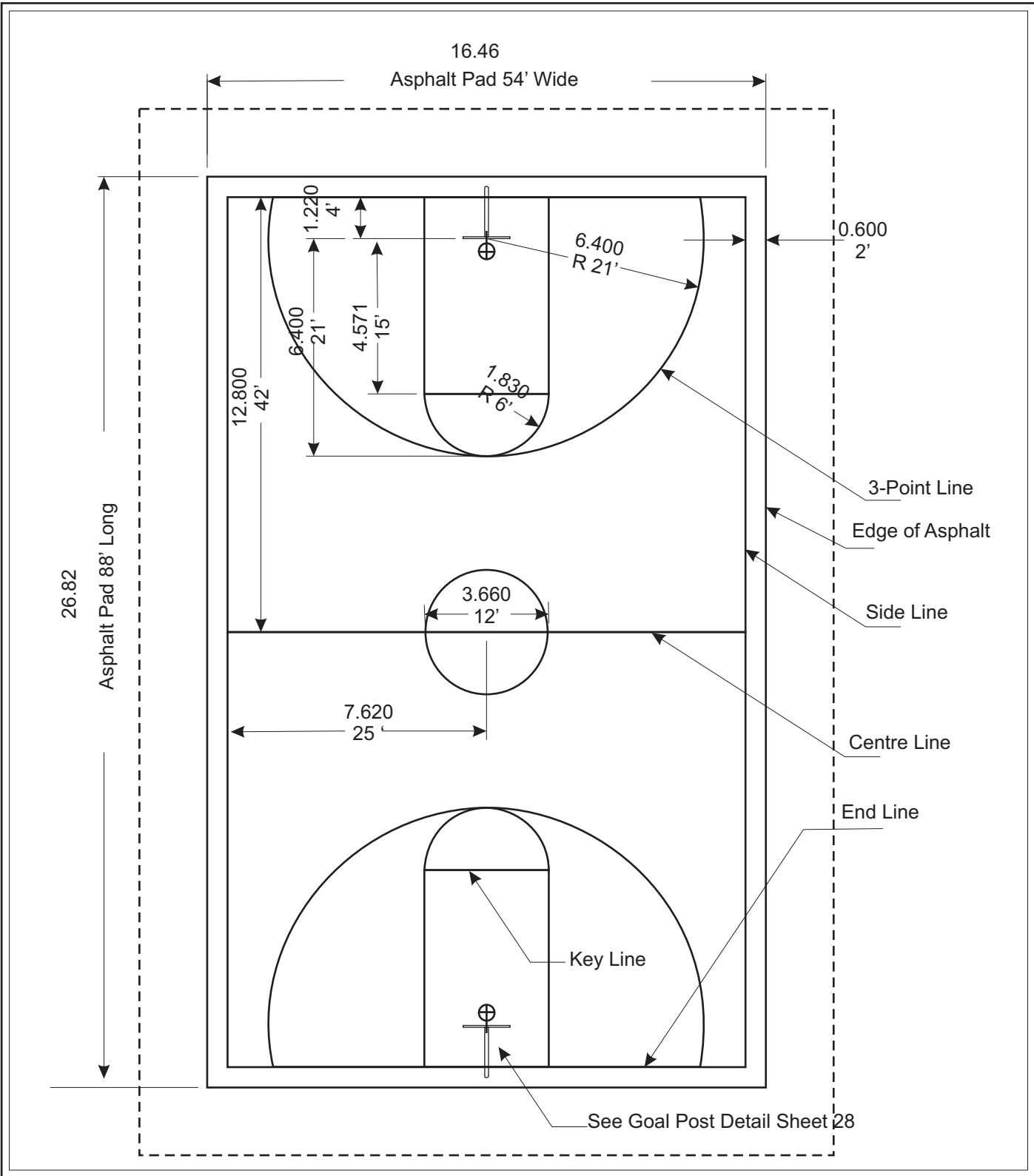

CITY OF CHESTERMERE
Development & Infrastructure
Services
Parks Department



PR.0020.11
January, 2015

SHEET TITLE:
Basketball Court Construction

LANDSCAPE STANDARDS & SPECIFICATIONS

SHEET NO:	COCH-LS 27
DRAWN BY:	CB
DATE:	2013Aug
SCALE:	N.T.S.
<i>Units are in metres unless otherwise noted.</i>	
<i>Source: City of Calgary Standard Specifications for Landscape Construction, 2013.</i>	

LEGEND & REFERENCES:

1. Two metre (2.0 m) minimum buffer around asphalt edge.
2. All lines to be masked and striped with 100% acrylic latex paint only.

Fan-shaped 6 mm cast aluminum backboard with reinforcing ribs and 12 mm thick goal mounting area. Powder coated white, mounted with tamper-proof hardware. Includes orange painted shooter's square.

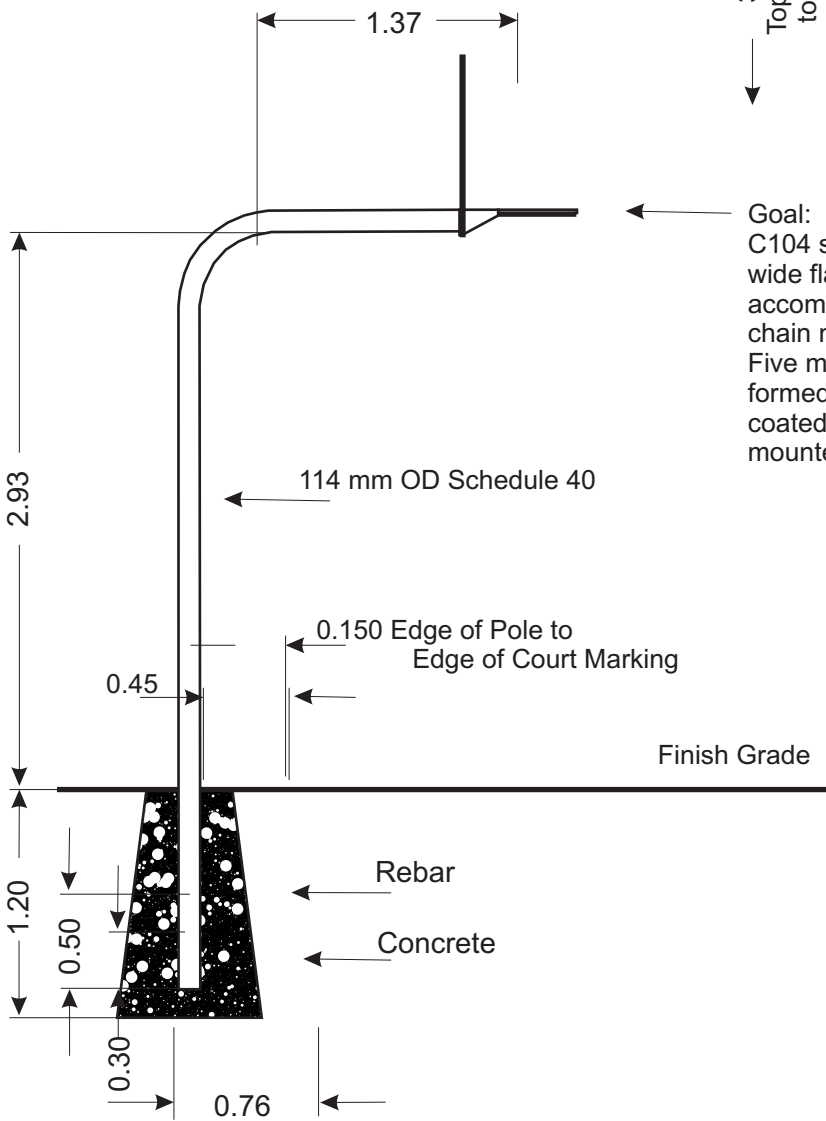
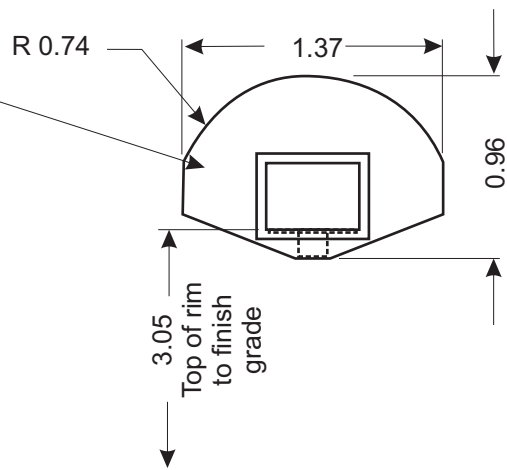

Goal: 2-16 mm high strength cold rolled C104 steel rim and 5 mm thick x 25 mm wide flat bar brace to individually accommodate net ties for nylon and chain nets. Five millimetres (5 mm) one-piece formed full-back/side plate. Powder coated orange. All components front mounted.

CITY OF CHESTERMERE
Development & Infrastructure
Services
Parks Department



PR.0020.11
January, 2015

SHEET TITLE:

Basketball Court Construction
- Goal Post Detail -

LANDSCAPE STANDARDS & SPECIFICATIONS

SHEET NO: COCH-LS 28

DRAWN BY: CB

DATE: 2013Aug

SCALE: N.T.S.

Units are in metres unless otherwise noted.

Source: City of Calgary Standard Specifications for Landscape Construction, 2013.

LEGEND & REFERENCES:

1. Post, Goal and Backboard are all mounted together with the same hardware.

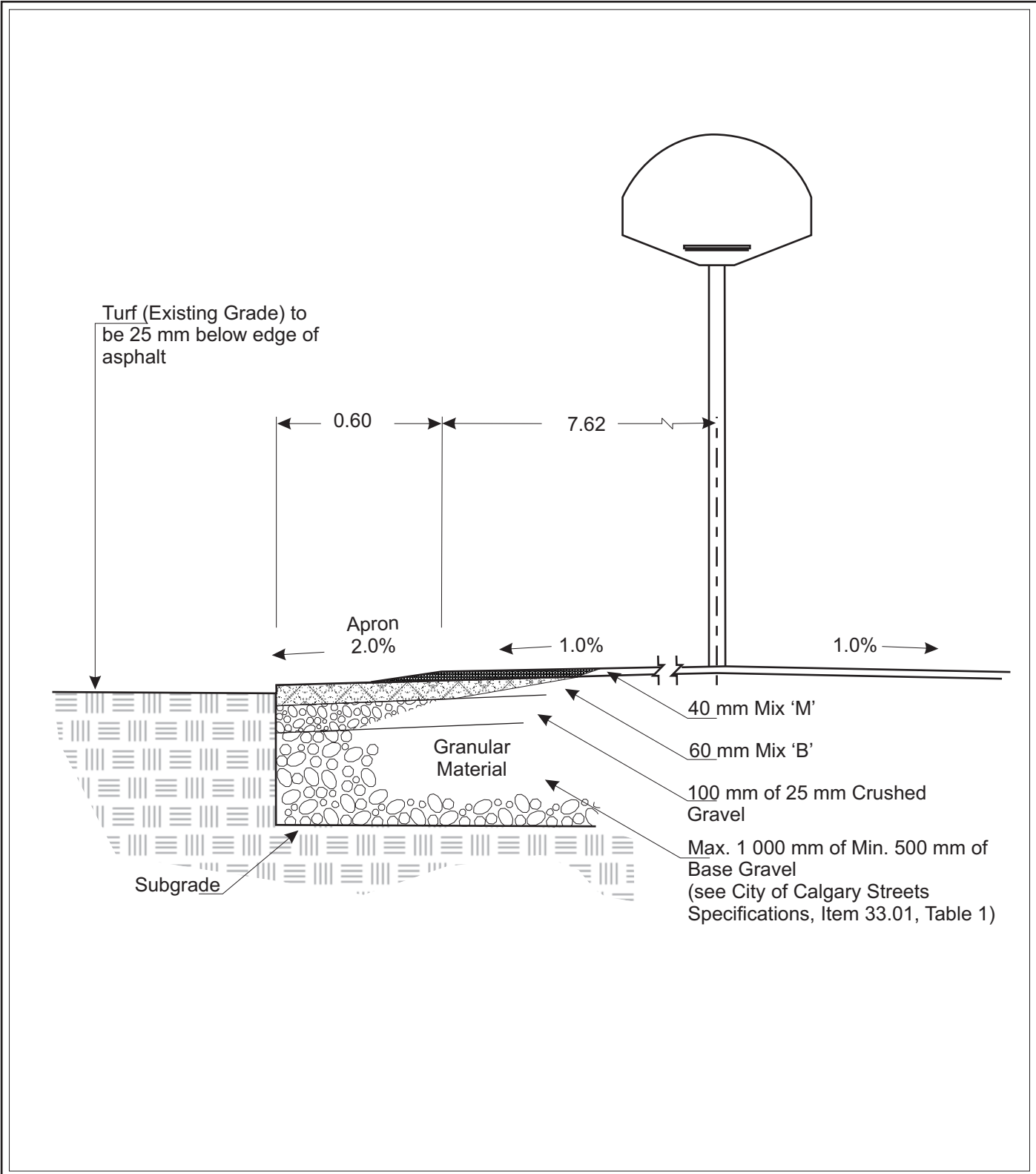

CITY OF CHESTERMERE
 Development & Infrastructure Services
 Parks Department



PR.0020.11
 January, 2015

SHEET TITLE:
 Basketball Court Construction
 - Surface Details -

LANDSCAPE STANDARDS & SPECIFICATIONS

SHEET NO:	COCH-LS 29
DRAWN BY:	CB
DATE:	2013Aug
SCALE:	N.T.S.

Units are in metres unless otherwise noted.

Source: City of Calgary Standard Specifications for Landscape Construction, 2013.

LEGEND & REFERENCES:

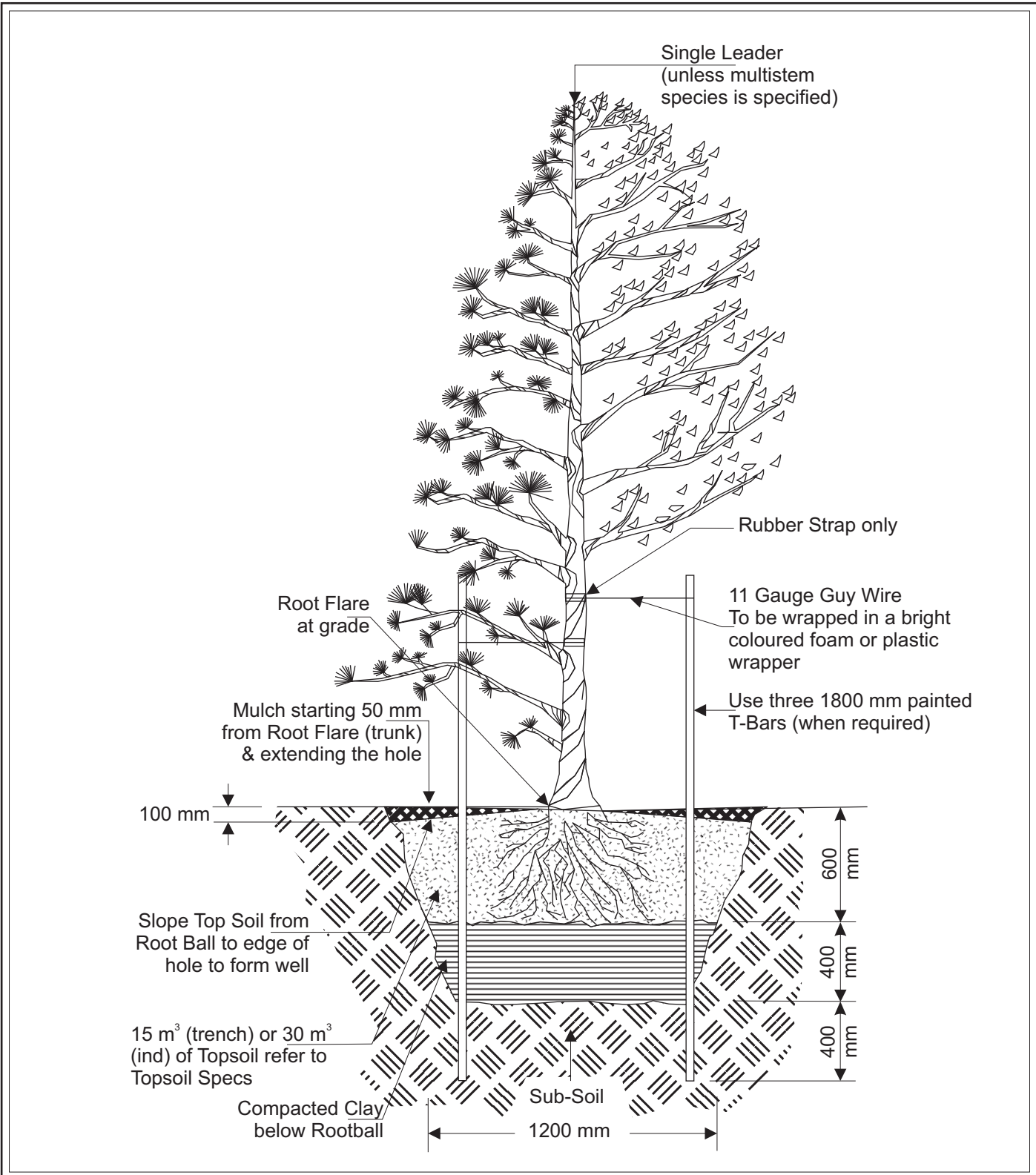

CITY OF CHESTERMERE
 Development & Infrastructure
 Services
 Parks Department



PR.0020.11
 January, 2015

SHEET TITLE:
 Tree Planting Detail
 - 35 mm Caliper Trees &
 Smaller Bare Root -

**LANDSCAPE STANDARDS &
 SPECIFICATIONS**

SHEET NO:	COCH-LS 30
DRAWN BY:	CB
DATE:	2013Dec
SCALE:	N.T.S.

Units are in millimetres unless otherwise noted.

Source: City of Calgary Standard Specifications for Landscape Construction, 2013.

- LEGEND & REFERENCES:**
1. Spread out roots in hole (at least twice the diameter of the root spread).
 2. Flush out broken or frayed root ends with secateurs.
 3. Hold trunk vertical, backfill around roots with shredded loam mix, continuously packing the soil until firm.
 4. Tree should be planted in a 75-1000 mm tree well at same original growing depth as in nursery.
 5. Bars should be hammered down at least 400 mm into sub-soil base footing.
 6. If required, use rubber straps at end of all guy wires to protect tree at point of contact.
 7. Prune dead branches to maintain natural form of tree.

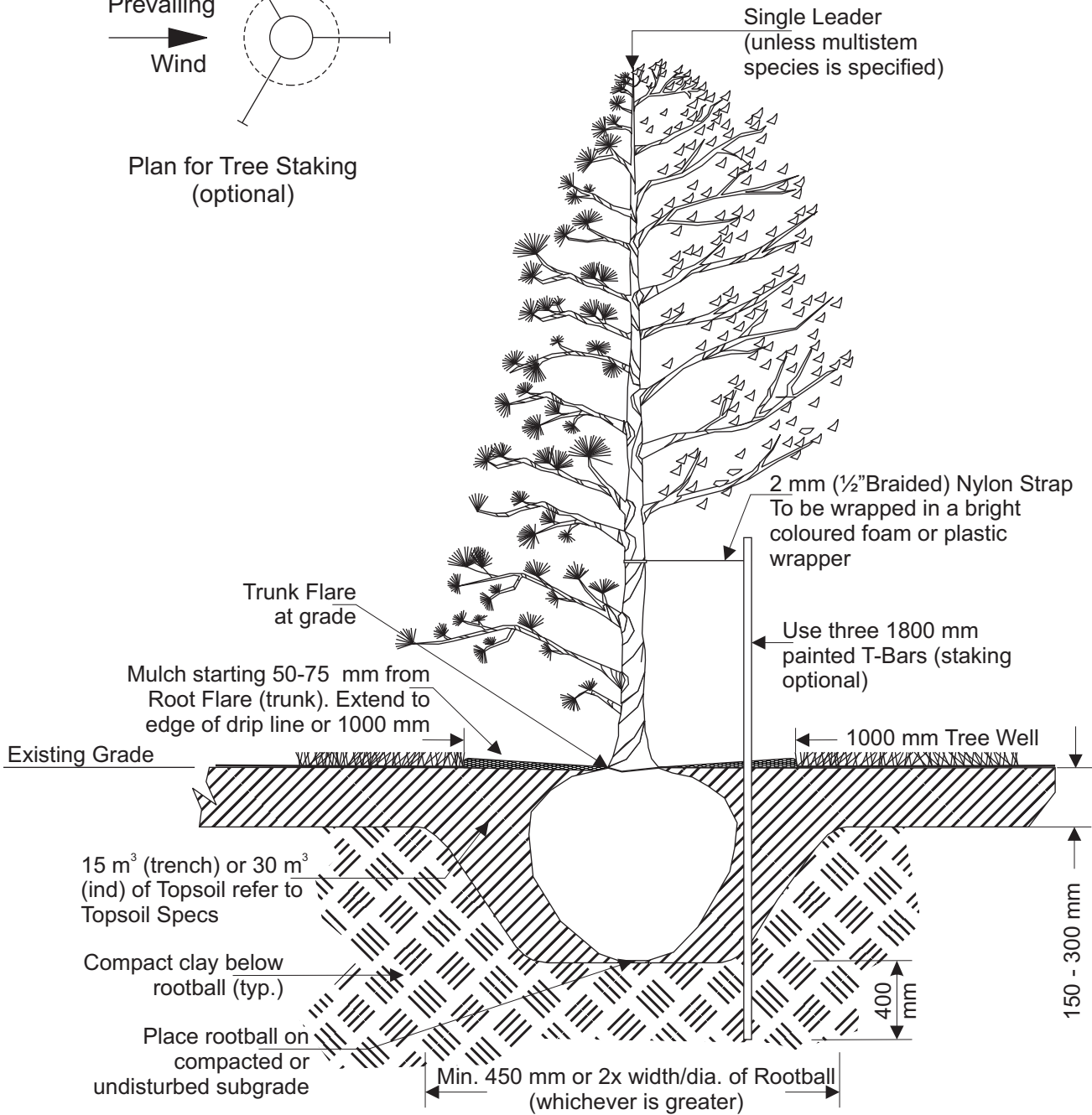
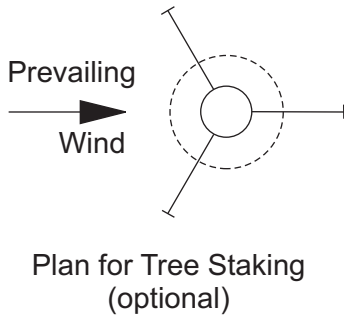

CITY OF CHESTERMERE
Development & Infrastructure
Services
Parks Department



PR.0020.11
January, 2015

SHEET TITLE:
Tree Planting Detail
- 40 to 100 mm Caliper Trees,
Backhoe Dug -

**LANDSCAPE STANDARDS &
SPECIFICATIONS**

SHEET NO: COCH-LS 31
DRAWN BY: CB
DATE: 2013Dec
SCALE: N.T.S.

*Units are in millimetres unless
otherwise noted.*

*Source: City of Calgary Standard
Specifications for Landscape
Construction, 2013.*

LEGEND & REFERENCES:

For Coniferous or Deciduous, irrigated sites, basket or ball & burlap trees. On non-irrigated sites an increase in topsoil depth to increase water holding capacity shall be required.

1. Trees to be planted at grade with trunk flare visible; no more than 25 mm above grade.
2. Stake beyond edge of root ball. Bars should be hammered into solid footing at least 400 mm into sub-soil base (if required).
3. Tree in wire basket, cut & remove strapping and the horiz/vert wires of the wire basket to a min. depth of 1/3. Pull back burlap to this same min. depth.
4. On sites of extreme compaction scarifying is recommended.
6. 50-75 mm tree well depth option for non-irrigated sites.

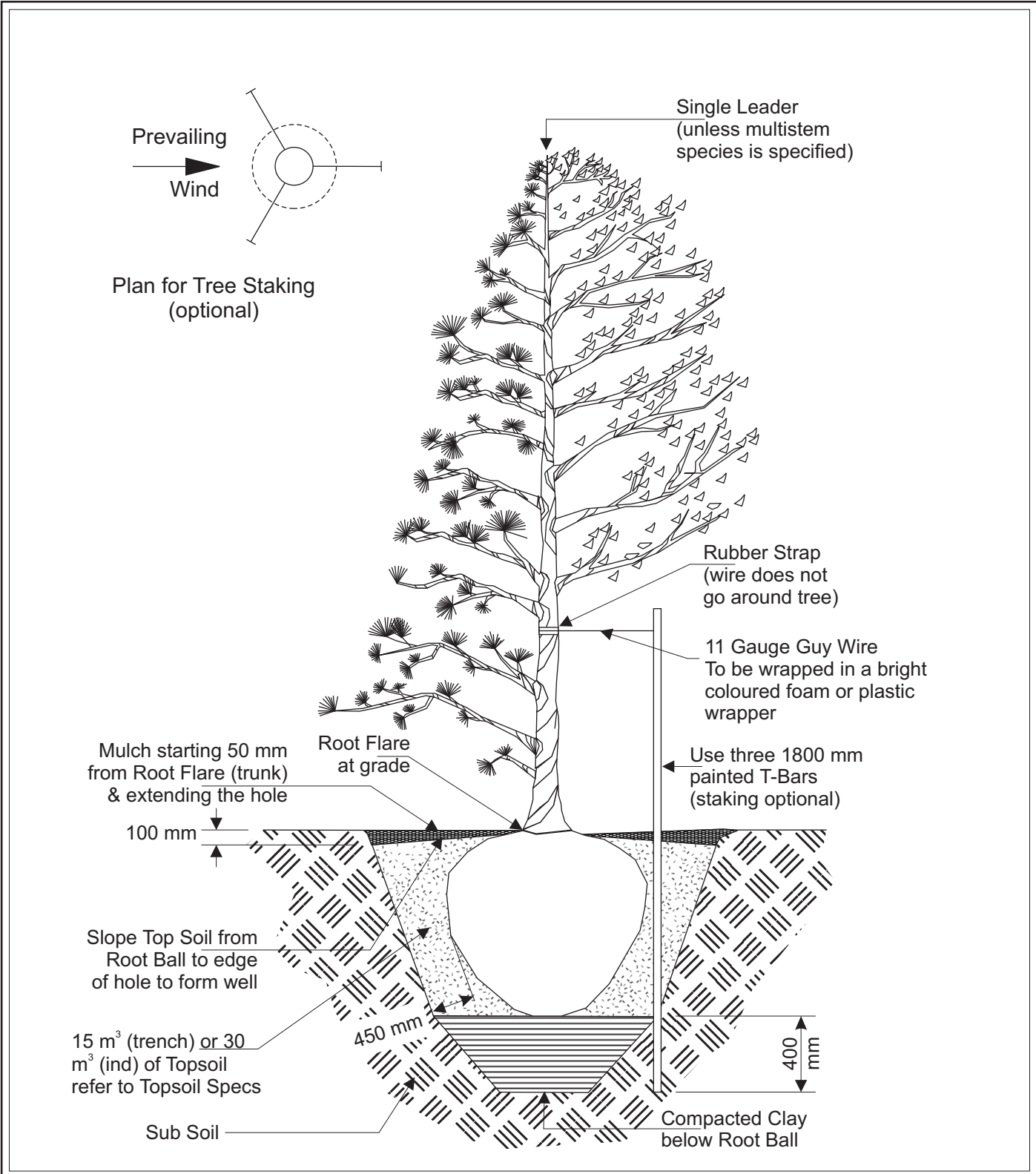

CITY OF CHESTERMERE
 Development & Infrastructure
 Services
 Parks Department



PR.0020.11
 January, 2015

SHEET TITLE:
 Tree Planting Detail
 - 40 to 100 mm Caliper Trees,
 Spade Dug -

**LANDSCAPE STANDARDS &
 SPECIFICATIONS**

SHEET NO:	COCH-LS 32
DRAWN BY:	CB
DATE:	2013Dec
SCALE:	N.T.S.
<i>Units are in millimetres unless otherwise noted.</i>	
<i>Source: City of Calgary Standard Specifications for Landscape Construction, 2013.</i>	

LEGEND & REFERENCES:

For either Coniferous or Deciduous, Basket or Ball & Burlap Trees.

1. Stake beyond edge of root ball.
2. Tree should be planted 75-100 mm below ground level.
3. Bars should be hammered into solid footing at least 400 mm into sub-soil base.
4. If tree is in wire basket, cut & remove strapping and the horizontal/vertical wires of the wire basket to a minimum depth of 200 mm from the top of the root ball. Pull back burlap to this same minimum depth.

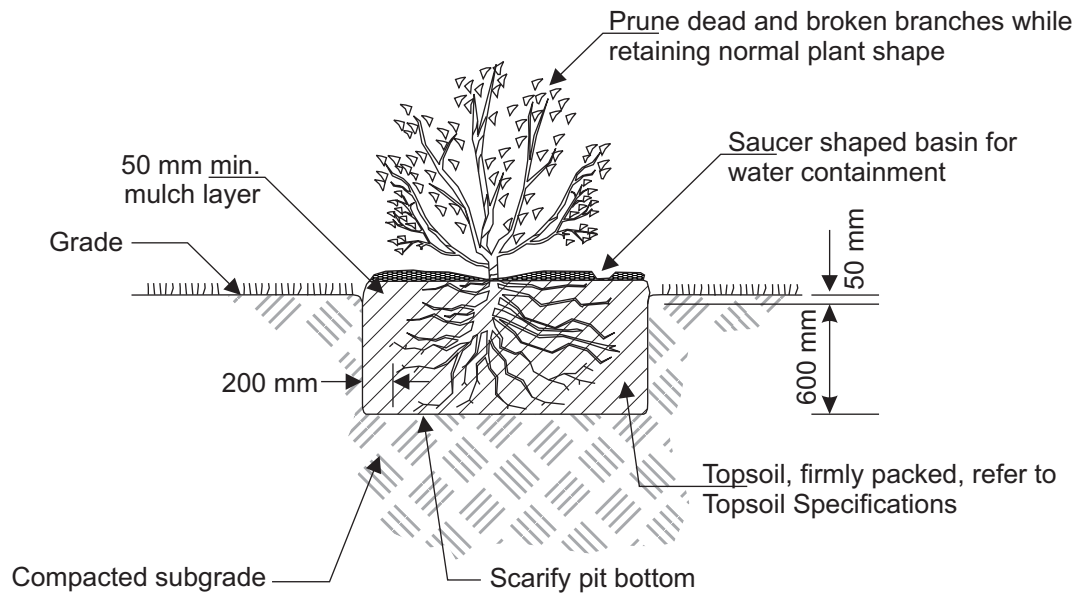

Shrub Pit

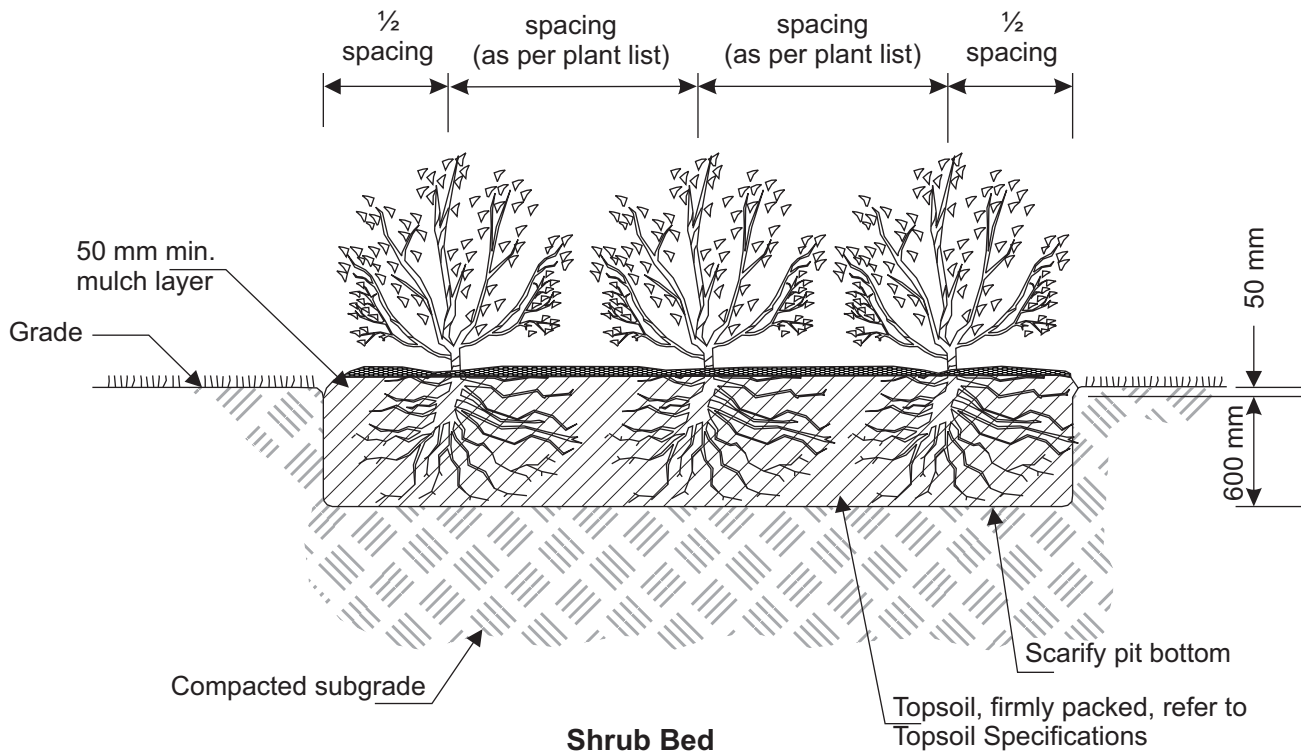

Shrub Bed

CITY OF CHESTERMERE
 Development & Infrastructure
 Services
 Parks Department



PR.0020.11
 January, 2015

SHEET TITLE:
 Shrub Planting Detail

LANDSCAPE STANDARDS & SPECIFICATIONS

SHEET NO:	COCH-LS 33
DRAWN BY:	CB
DATE:	2013Aug12
SCALE:	N.T.S.
<i>Units are in metric unless otherwise noted.</i>	
<i>Source: City of Calgary Standard Specifications for Landscape Construction, 2013.</i>	

LEGEND & REFERENCES:

- Shrub planting detail to be used for all potted deciduous or coniferous shrubs.

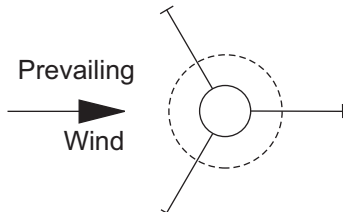

Plan for Tree Staking (optional)

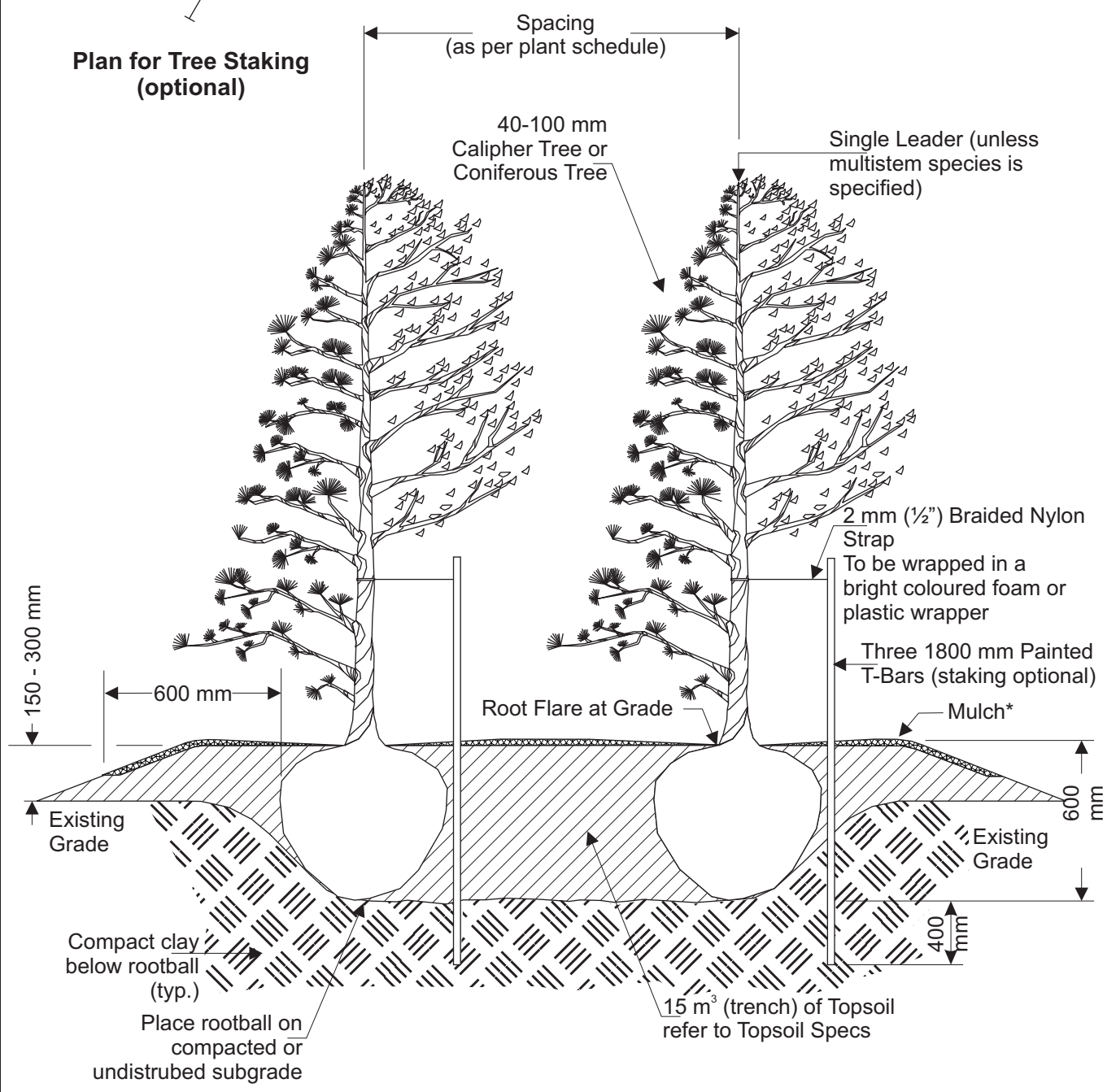

CITY OF CHESTERMERE
 Development & Infrastructure Services
 Parks Department



PR.0020.11
 January, 2015

SHEET TITLE:
 Tree Planting
 - Bed Detail -

LANDSCAPE STANDARDS & SPECIFICATIONS

SHEET NO:	COCH-LS 34
DRAWN BY:	CB
DATE:	2013Dec
SCALE:	N.T.S.

Units are in millimetres unless otherwise noted.

Source: City of Calgary Standard Specifications for Landscape Construction, 2013.

LEGEND & REFERENCES:

- * 50-75 mm depth, starting 50 mm from root flare (trunk). Extend to the edge of drip line of 1000 mm.
- 1. Edge of bed to be staked & approved by City's Landscape Technician.
- 2. If required, stake beyond edge of root ball. Bars should be hammered at least 400 mm into sub-soil base into solid footing.
- 3. If tree is in wire basket, cut & remove strapping and the horizontal/vertical wires of the upper 1/3 as min. Pull back burlap to same min. depth.
- 4. Prune dead branches to maintain natural form of tree.
- 5. Option to raise bed 150-300 mm.

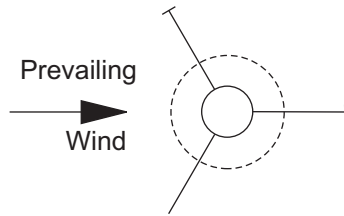

Plan for Tree Staking (optional)

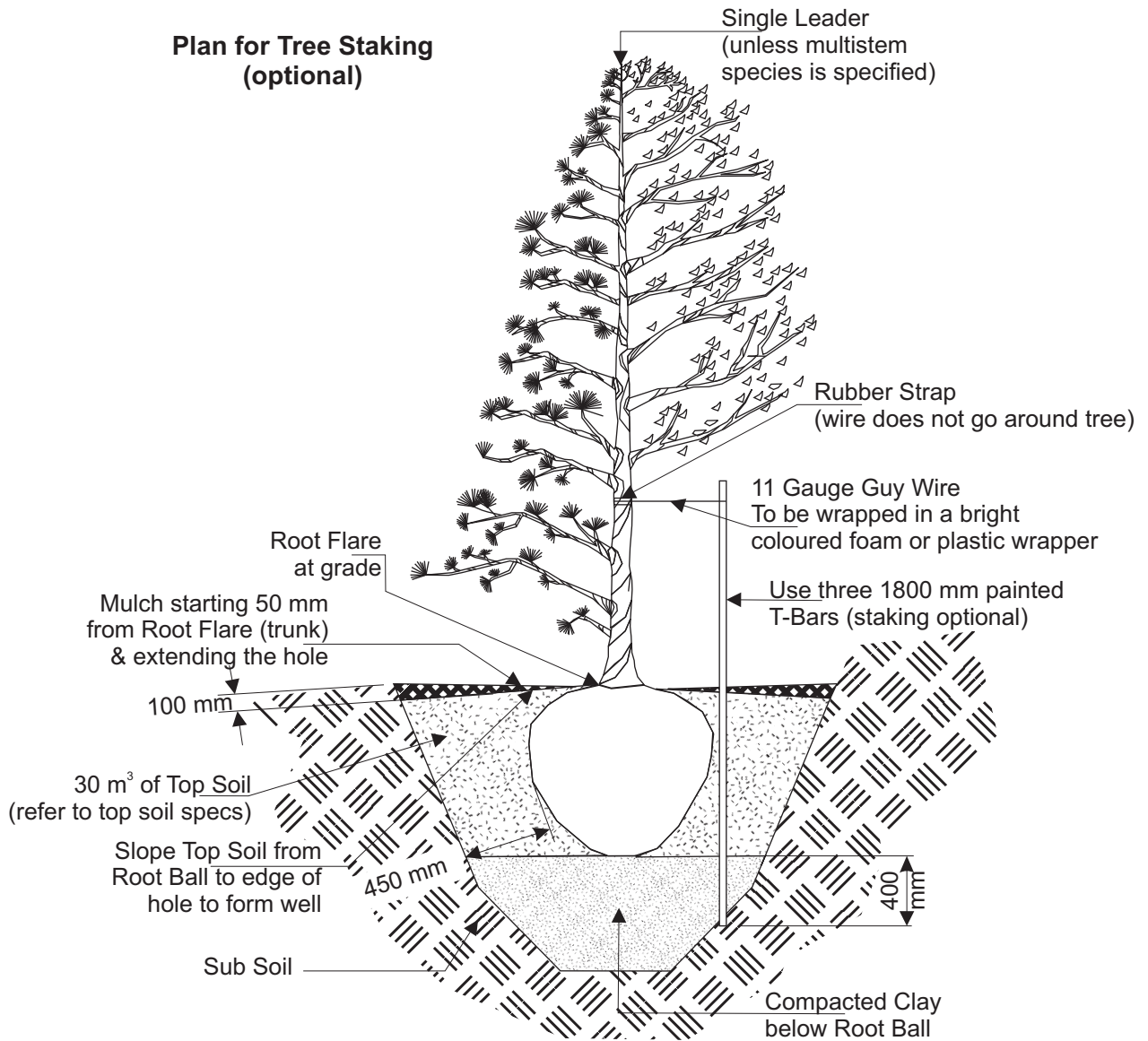

CITY OF CHESTERMERE

Development & Infrastructure Services
Parks Department



PR.0020.11
January, 2015

SHEET TITLE:

Tree Planting Details
- Slopes -

LANDSCAPE STANDARDS & SPECIFICATIONS

SHEET NO: COCH-LS 35

DRAWN BY: CB

DATE: 2013Dec

SCALE: N.T.S.

Units are in millimetres unless otherwise noted.

Source: City of Calgary Standard Specifications for Landscape Construction, 2013.

LEGEND & REFERENCES:

1. Do not allow air pockets to form when back filling.
2. Stake beyond edge of root ball.
3. Tree should be planted 75-100 mm below ground level.
4. Barbs should be hammered down into soil footing (min. 400 mm into sub-soil base).
5. If tree is in wire basket, cut & remove strapping and the horizontal/vertical wires of the wire basket to a min. depth of 200 mm from top of root ball. Pull back burlap to same min. depth.
6. Use rubber straps at end of all guy wires to protect the tree at point of contact.
7. Prune dead branches to maintain natural form of tree.

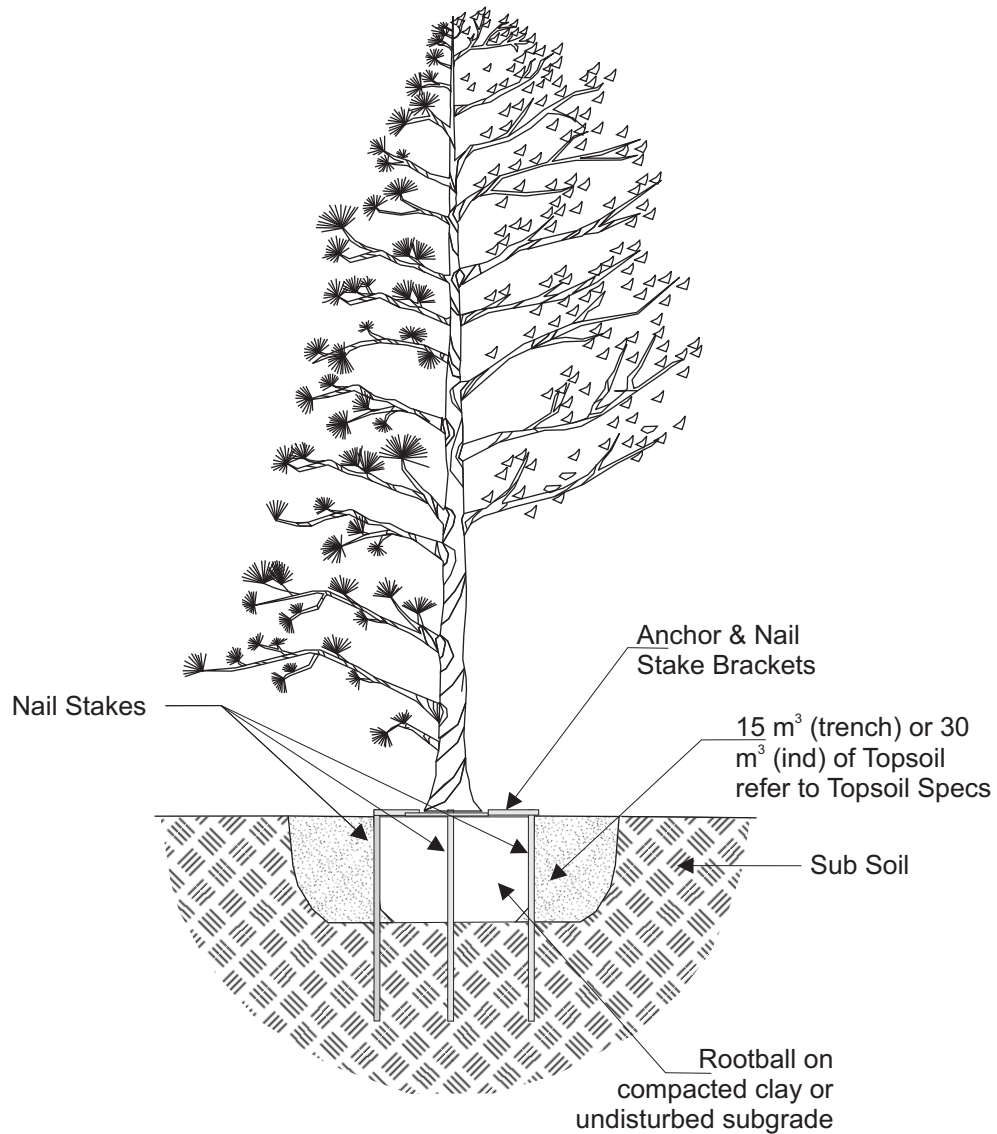
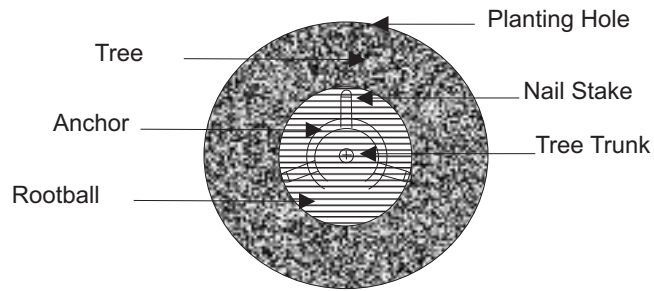

CITY OF CHESTERMERE

Development & Infrastructure
Services
Parks Department



PR.0020.11
January, 2015

SHEET TITLE:

Tree Planting Details
- Tree Anchor -

**LANDSCAPE STANDARDS &
SPECIFICATIONS**

SHEET NO: COCH-LS 36

DRAWN BY: CB

DATE: 2013Dec

SCALE: N.T.S.

*Units are in millimetres unless
otherwise noted.*

*Source: Source: City of Calgary
Standard Specifications for Landscape
Construction, 2013. Various Internet
Sites.*

LEGEND & REFERENCES:

Stake-less anchor system are now available as a option. All stake-less anchor systems at time of preliminary design will be reviewed by the City's landscape technician. Submission for review shall include the manufacturers' product specifications and installation and maintenance procedures and warranty information.

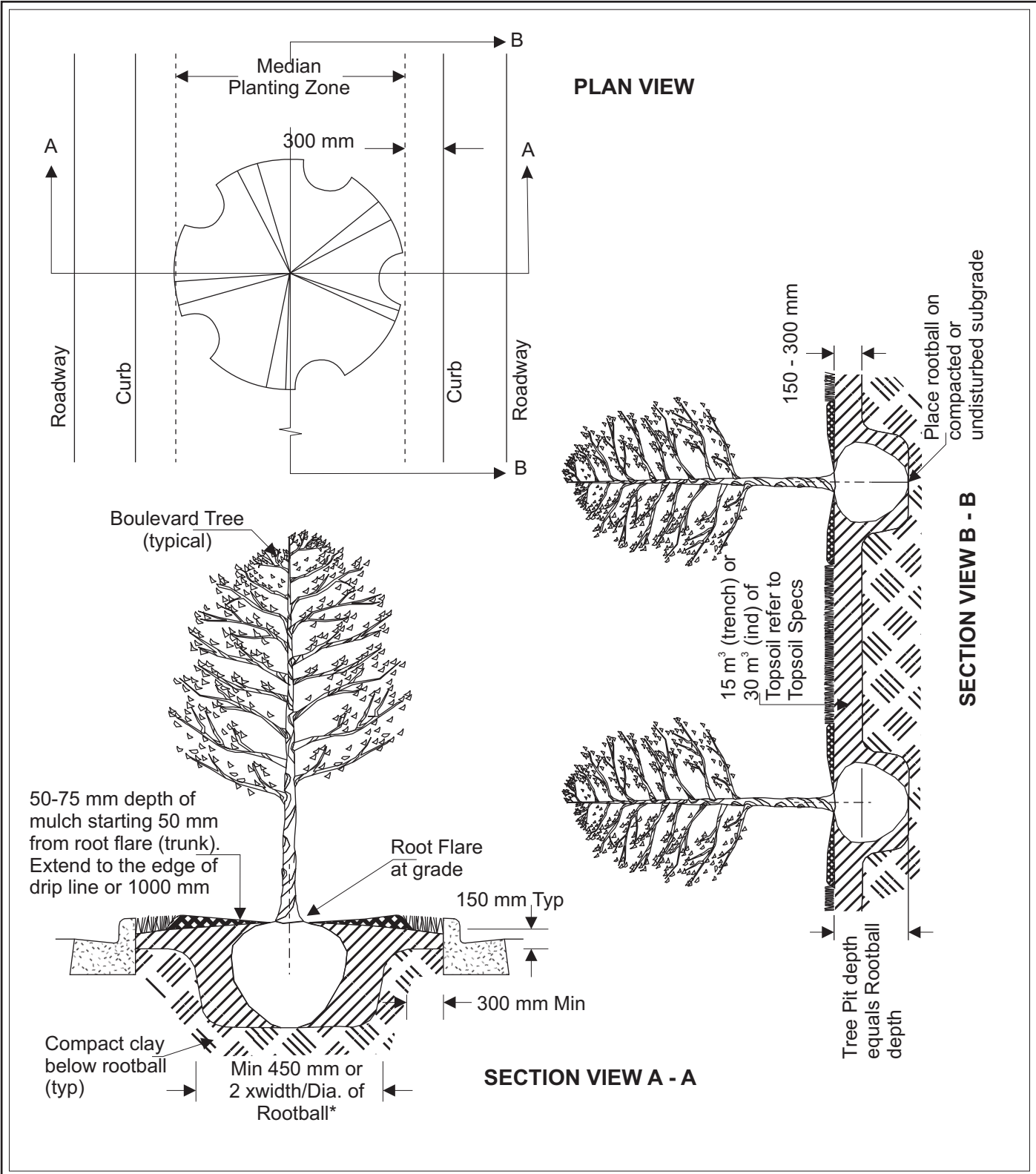

CITY OF CHESTERMERE
 Development & Infrastructure Services
 Parks Department



PR.0020.11
 January, 2015

SHEET TITLE:
 Tree Planting & Trench Details
 - Boulevards & Medians -

LANDSCAPE STANDARDS & SPECIFICATIONS

SHEET NO:	COCH-LS 37
DRAWN BY:	CB
DATE:	2013Dec
SCALE:	N.T.S.
<i>Units are in millimetres unless otherwise noted.</i>	
<i>Source: City of Calgary Standard Specifications for Landscape Construction, 2013.</i>	

- LEGEND & REFERENCES:**
- * whichever is greater.
- Trees to be planted at grade with trunk flare visible; no more than 25 mm above grade.
 - Staking if required; remove staking one year after installation.
 - Tree in wire basket - cut & remove topping and the horizontal/vertical wires of the upper 1/3 as min. Pull back burlap to the same min.
 - Prune dead branches to maintain natural form of tree.
 - Crown median to ensure positive drainage.

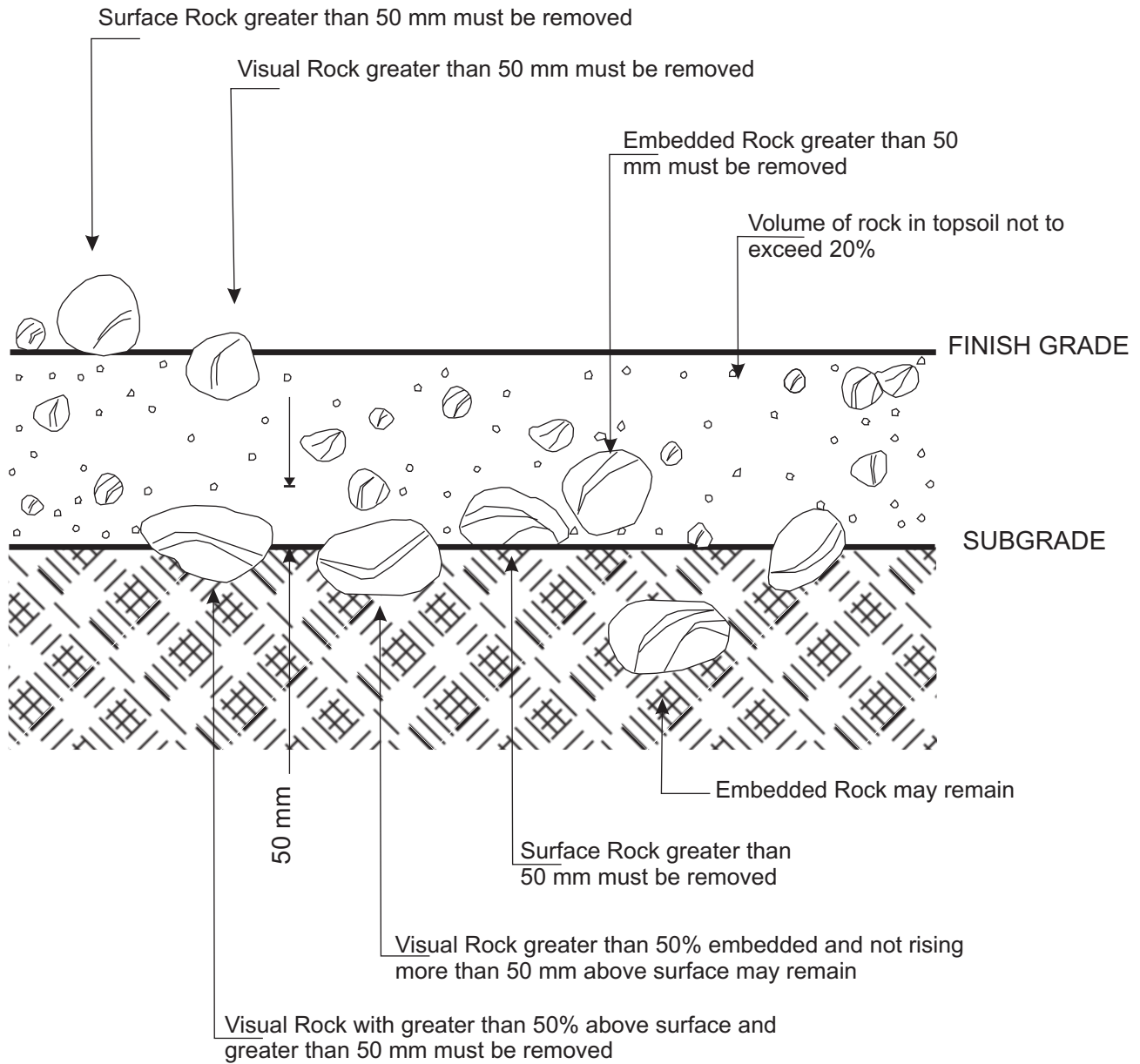

CITY OF CHESTERMERE

Development & Infrastructure
Services
Parks Department



PR.0020.11
January, 2015

SHEET TITLE:

Topsoil / Subgrade Preparation

LANDSCAPE STANDARDS & SPECIFICATIONS

SHEET NO: COCH-LS 38

DRAWN BY: CB

DATE: 2013Dec

SCALE: N.T.S.

Units are in millimetres unless otherwise noted.

Source: City of Calgary Standard Specifications for Landscape Construction, 2013.

LEGEND & REFERENCES:

1. Surface, visual or embedded rock that is greater than 25 mm must be removed for all sports fields.

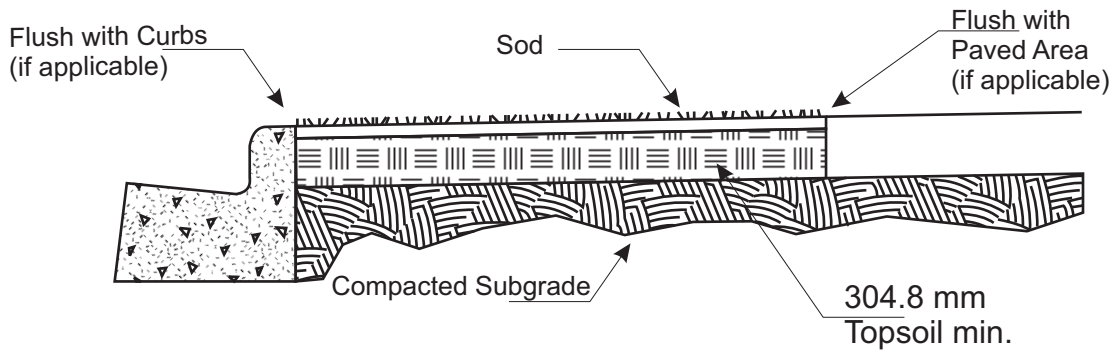

SECTION THROUGH SOD

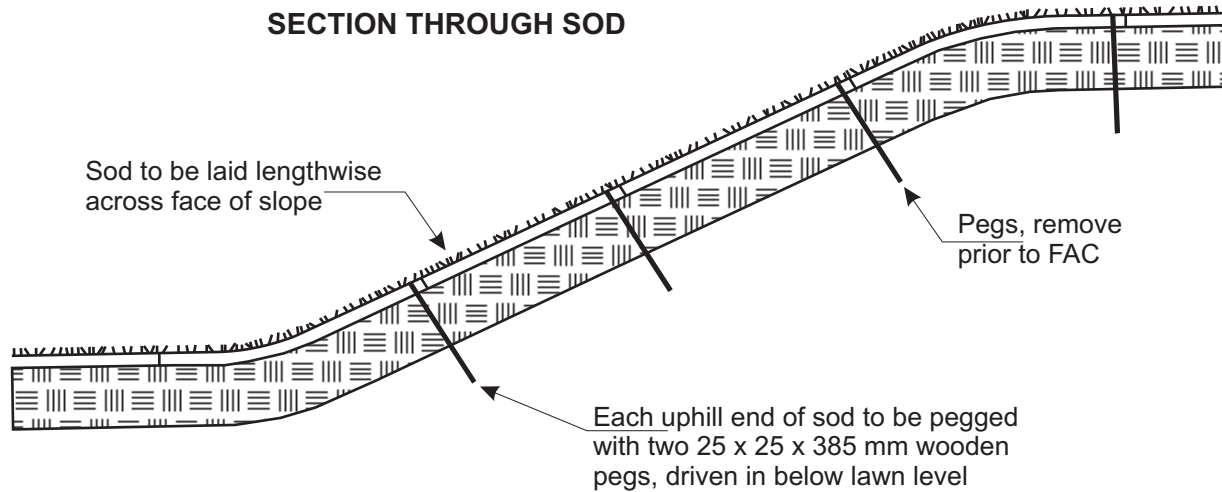

CROSS SECTION OF 3H:1V SLOPE

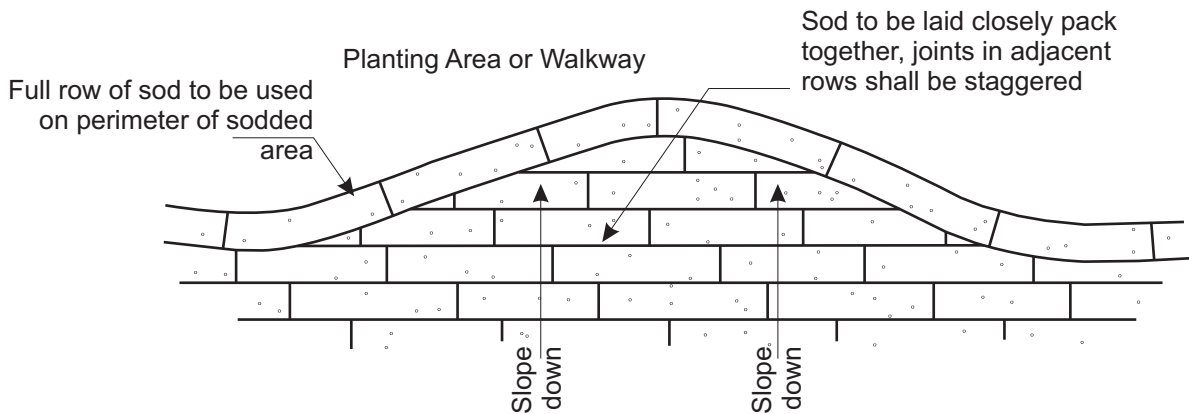

PLAN VIEW OF SOD LAYOUT AND EDGING

CITY OF CHESTERMERE
 Development & Infrastructure
 Services
 Parks Department



PR.0020.11
 January, 2015

SHEET TITLE:

Sod Detail

**LANDSCAPE STANDARDS &
 SPECIFICATIONS**

SHEET NO: COCH-LS 39

DRAWN BY: CB

DATE: 2013Dec

SCALE: N.T.S.

Units are in millimetres unless otherwise noted.

Source: City of Calgary Standard Specifications for Landscape Construction, 2013.

LEGEND & REFERENCES:

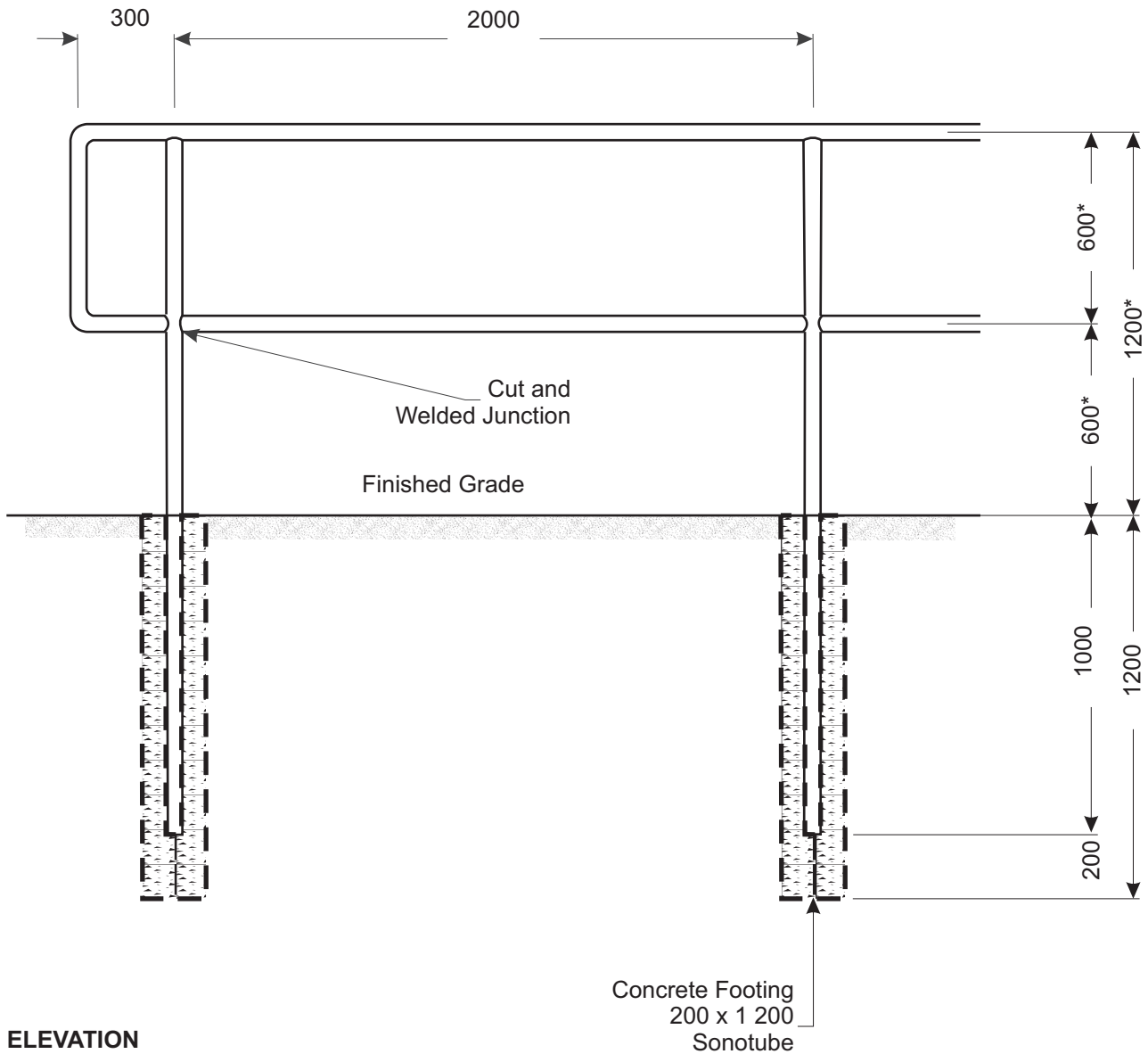

ELEVATION

CITY OF CHESTERMERE

Development & Infrastructure
Services
Parks Department



PR.0020.11
January, 2015

SHEET TITLE:

Pathway Handrail

**LANDSCAPE STANDARDS &
SPECIFICATIONS**

SHEET NO: COCH-LS 40

DRAWN BY: CB

DATE: 2013Aug

SCALE: N.T.S.

*Units are in millimetres unless
otherwise noted.*

*Source: City of Calgary Standard
Specifications for Landscape
Construction, 2013.*

LEGEND & REFERENCES:

* Total railing height increases to 1 400 mm when required on a bridge.

1. Posts - Schedule 40. 48 mm OD.
2. Rails 0.083 to 0.100 wall thickness. 48 mm OD.
3. Post and Rails to be steel pipe, continuous weld, all joints.

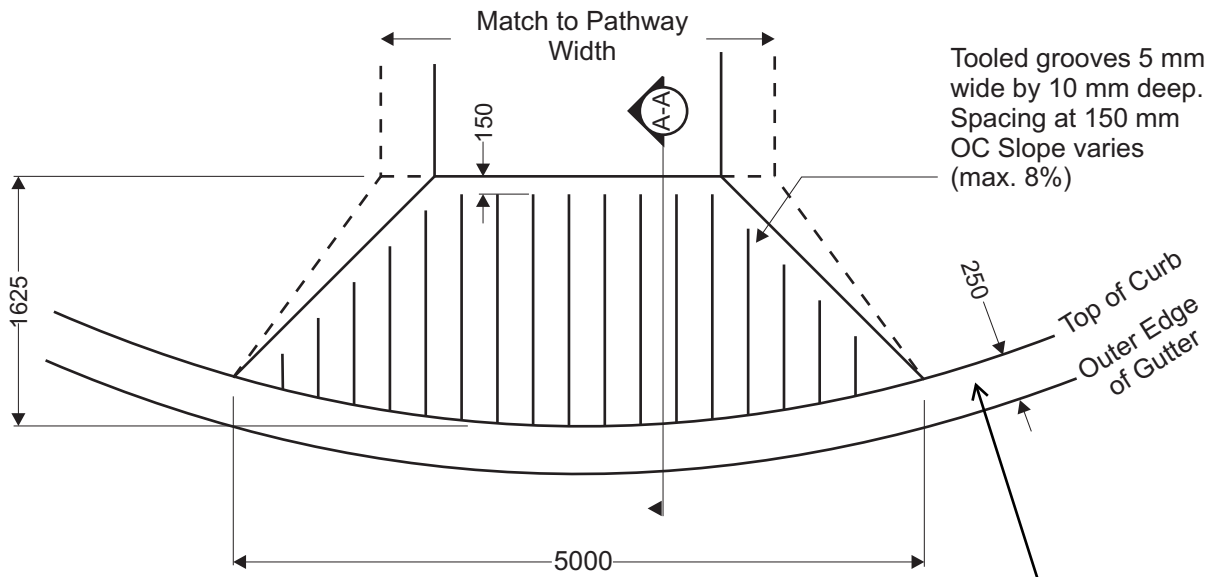

PLAN VIEW

Curb painting required 6m o.c of ramp.

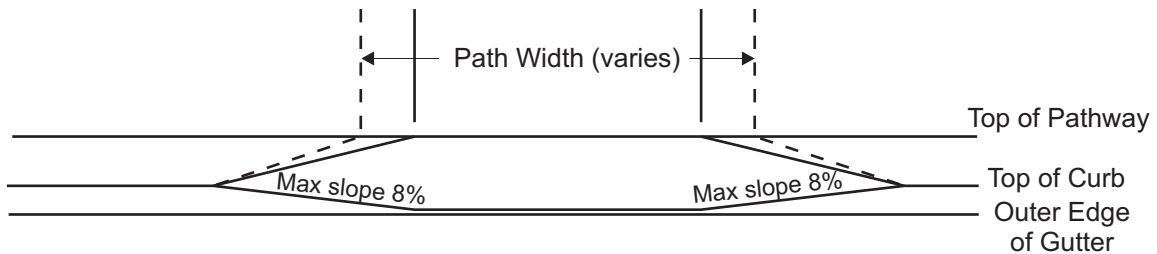

ELEVATION VIEW

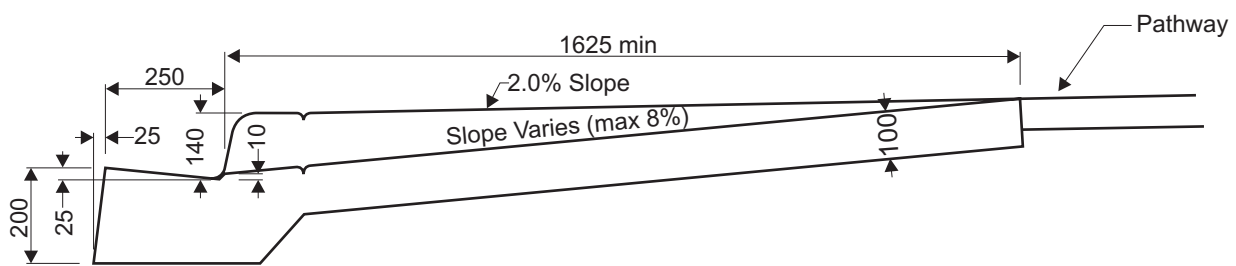

SECTION VIEW A - A

CITY OF CHESTERMERE
Development & Infrastructure
Services
Parks Department



PR.0020.11
January, 2015

SHEET TITLE:

Wheelchair Ramp
- Concrete -

**LANDSCAPE STANDARDS &
SPECIFICATIONS**

SHEET NO: COCH-LS 43

DRAWN BY: CB

DATE: 2013Aug

SCALE: N.T.S.

*Units are in millimetres unless
otherwise noted.*

*Source: City of Calgary Standard
Specifications for Landscape
Construction, 2013.*

LEGEND & REFERENCES:

1. Maximum slope of ramp eight percent (8%) (12.5:1).
2. Ramp surface to be textured concrete.

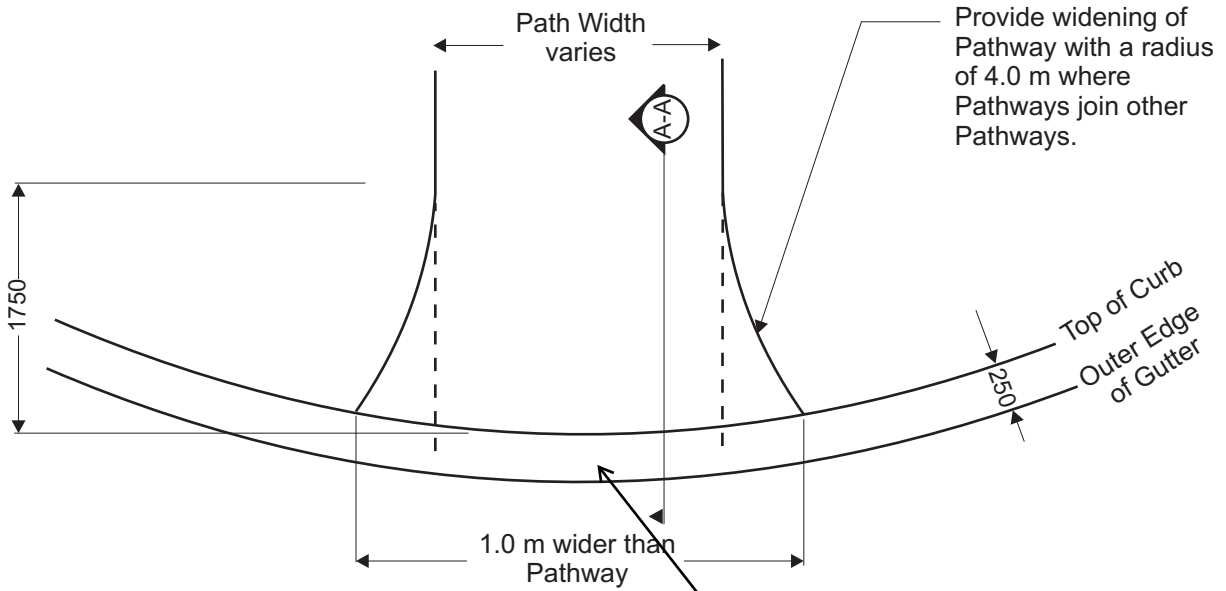

PLAN VIEW

Curb painting required 6m o.c of ramp.

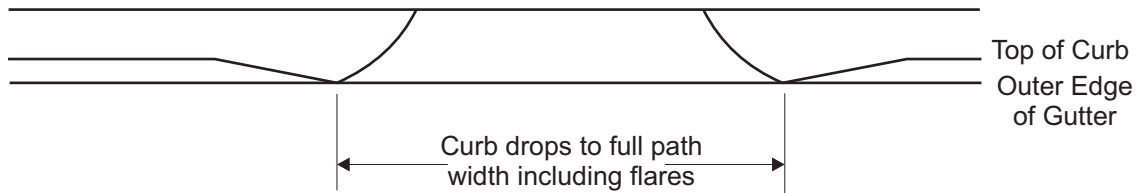

ELEVATION VIEW

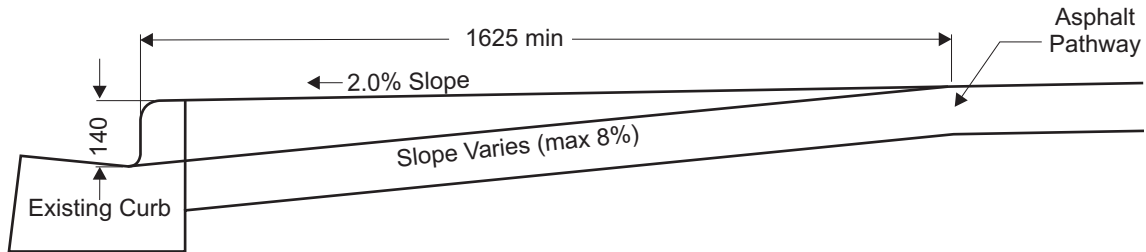

SECTION VIEW A - A

CITY OF CHESTERMERE
Development & Infrastructure
Services
Parks Department



PR.0020.11
January, 2015

SHEET TITLE:

Wheelchair Ramp
- Asphalt -

LANDSCAPE STANDARDS & SPECIFICATIONS

SHEET NO: COCH-LS 44

DRAWN BY: CB

DATE: 2013Aug

SCALE: N.T.S.

Units are in millimetres unless otherwise noted.

Source: City of Calgary Standard Specifications for Landscape Construction, 2013.

LEGEND & REFERENCES:

1. Maximum slope of ramp eight percent (8.0%).

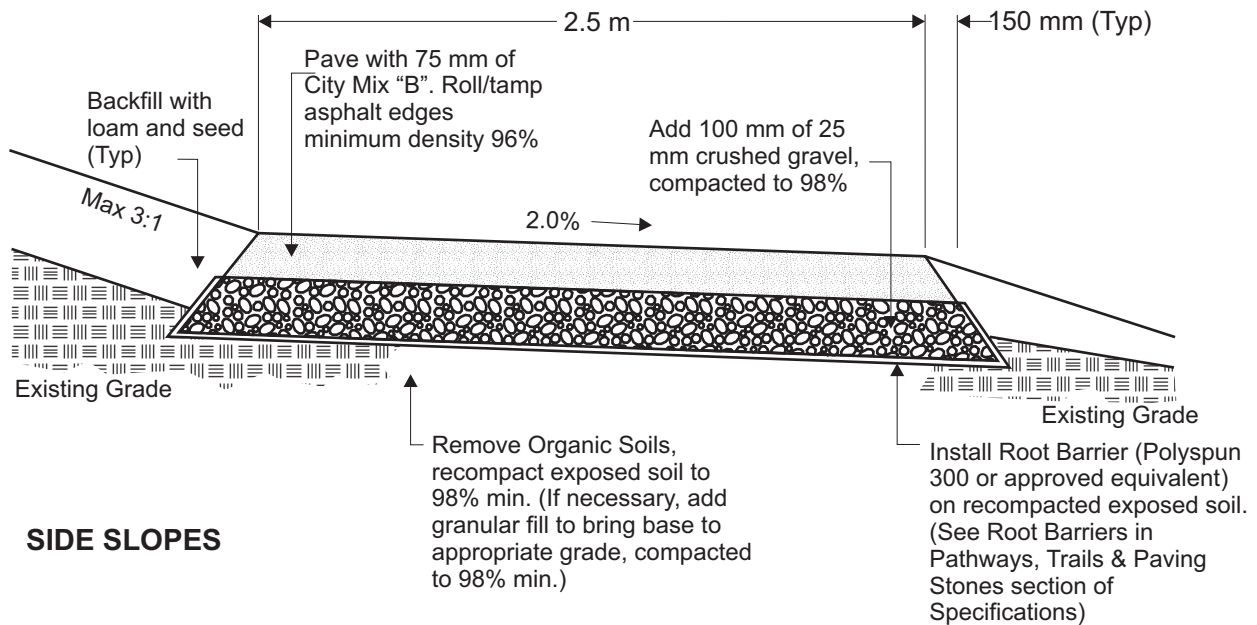
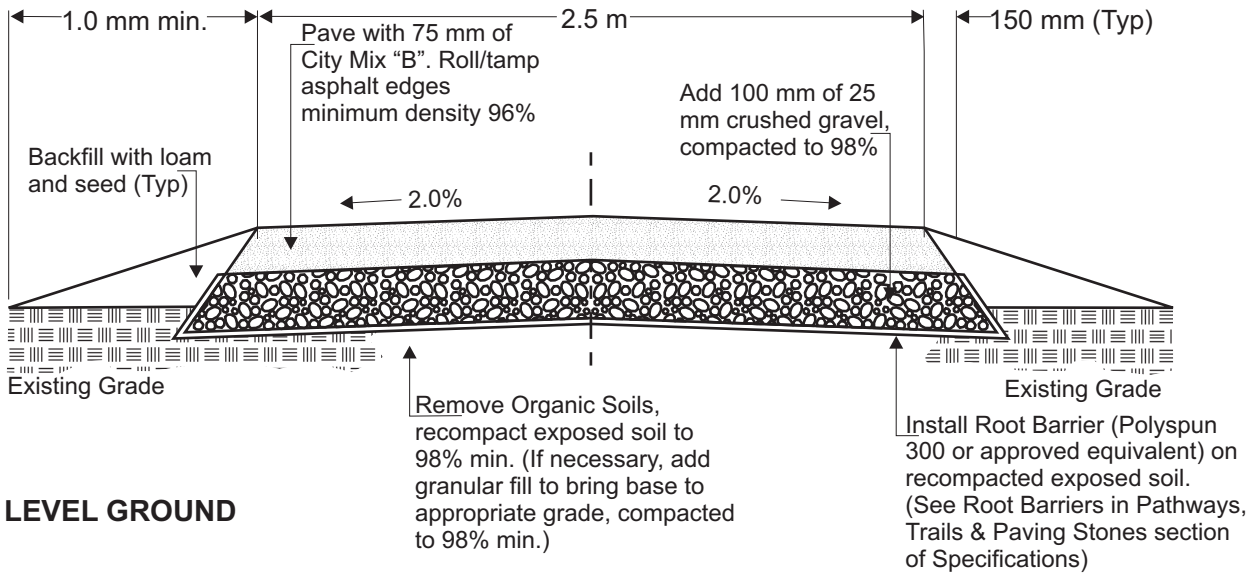

CITY OF CHESTERMERE
 Development & Infrastructure Services
 Parks Department



PR.0020.11
 January, 2015

SHEET TITLE:
 Local Pathway
 - Typical Cross Sections -

LANDSCAPE STANDARDS & SPECIFICATIONS

SHEET NO:	COCH-LS 45
DRAWN BY:	CB
DATE:	2013Aug
SCALE:	N.T.S.
<i>Units are in metres unless otherwise noted.</i>	
<i>Source: City of Calgary Standard Specifications for Landscape Construction, 2013.</i>	

LEGEND & REFERENCES:

- Asphalt Type "B" Mix. Refer to City of Calgary Road Construction Standard Specifications.

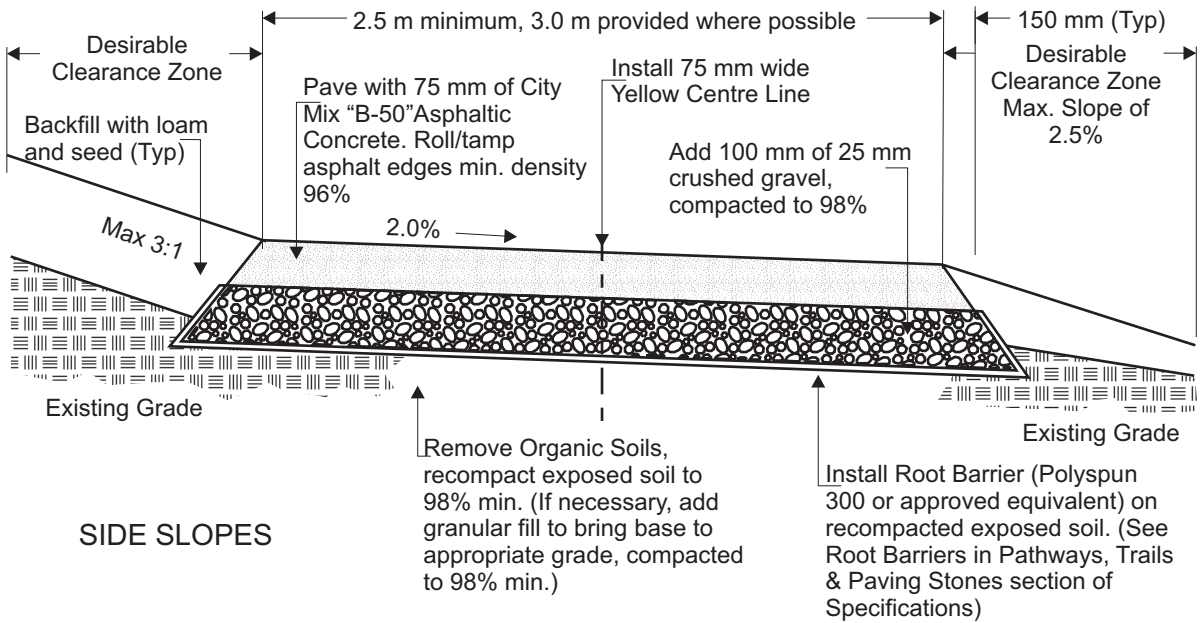
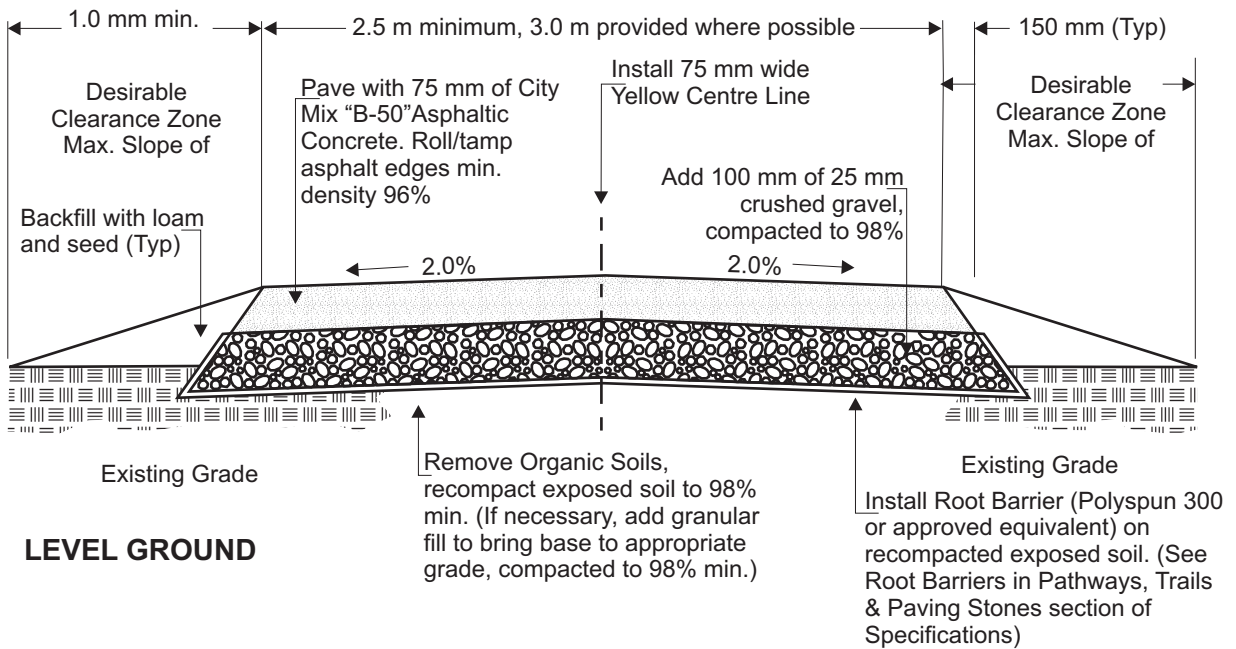

CITY OF CHESTERMERE
 Development & Infrastructure Services
 Parks Department



PR.0020.11
 January, 2015

SHEET TITLE:

Regional Pathway
 - Typical Cross Sections -

LANDSCAPE STANDARDS & SPECIFICATIONS

SHEET NO:	COCH-LS 46
DRAWN BY:	CB
DATE:	2013Aug
SCALE:	N.T.S.
<i>Units are in metres unless otherwise noted.</i>	
<i>Source: City of Calgary Standard Specifications for Landscape Construction, 2013.</i>	

LEGEND & REFERENCES:

- Asphalt Type "B" Mix. Refer to City of Calgary Road Construction Standard Specifications.
- Where Regional Pathway replaces a town sidewalk or is installed in a road right-of-way the desirable clearance zones will not apply.
- Safety railing, if required, may be installed within the desirable clearance zones.

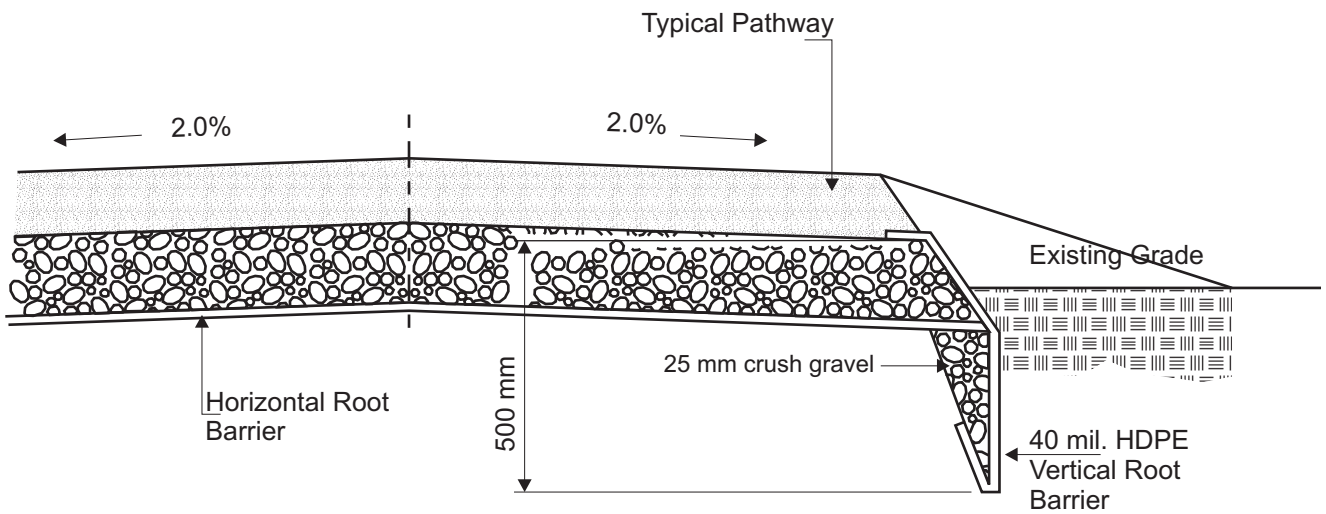

CITY OF CHESTERMERE

Development & Infrastructure
Services
Parks Department



PR.0020.11
January, 2015

SHEET TITLE:

Root Barriers

**LANDSCAPE STANDARDS &
SPECIFICATIONS**

SHEET NO: COCH-LS 47

DRAWN BY: CB

DATE: 2013Sept

SCALE: N.T.S.

*Units are in metres unless otherwise
noted.*

*Source: City of Calgary Standard
Specifications for Landscape
Construction, 2013.*

LEGEND & REFERENCES:

1. Within street right-of-way, compaction of 100 mm of 25 mm crushed gravel shall be 100% in accordance with Section 305.02.01 of the City of Calgary Roads Construction Standard Specifications.

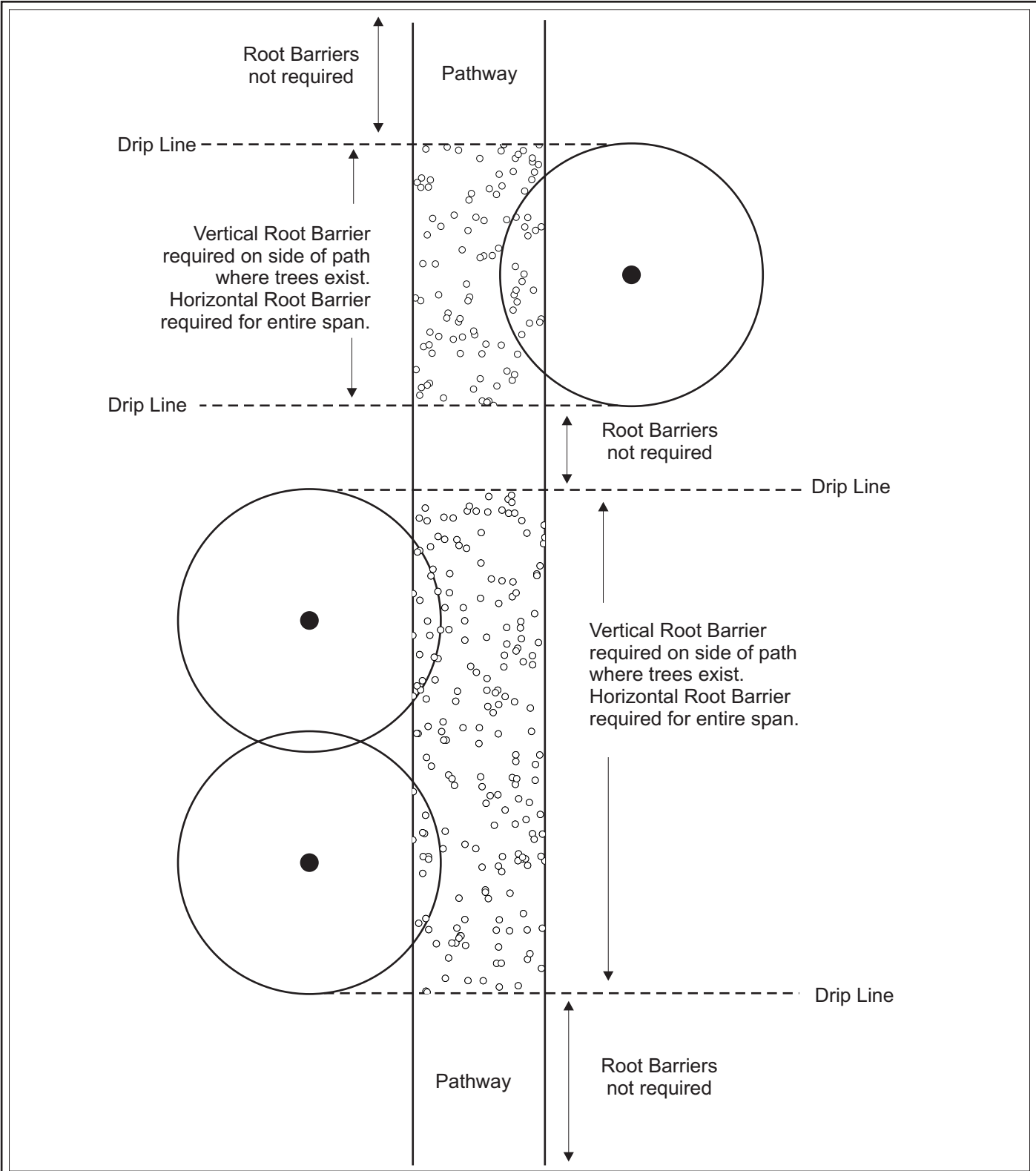

CITY OF CHESTERMERE
 Development & Infrastructure
 Services
 Parks Department



PR.0020.11
 January, 2015

SHEET TITLE:
 Root Barriers
 - Location -

LANDSCAPE STANDARDS & SPECIFICATIONS

SHEET NO:	COCH-LS 48
DRAWN BY:	CB
DATE:	2013Sept
SCALE:	N.T.S.

Source: City of Calgary Standard Specifications for Landscape Construction, 2013.

LEGEND & REFERENCES:

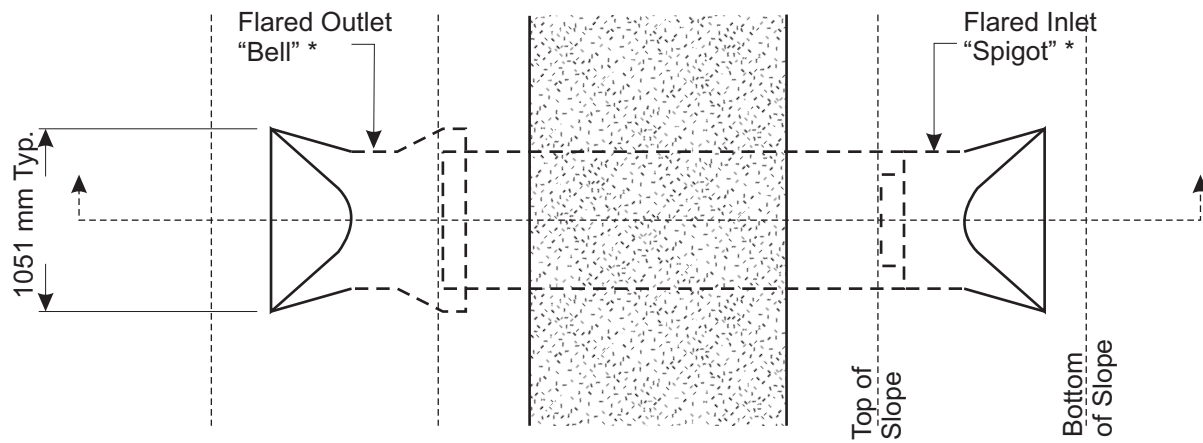

PLAN VIEW

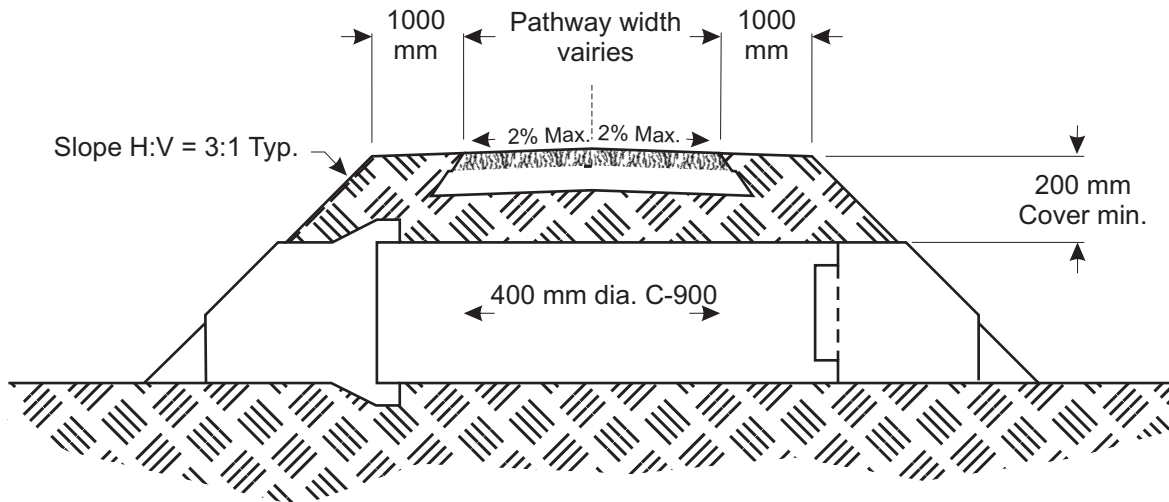

CROSS SECTION

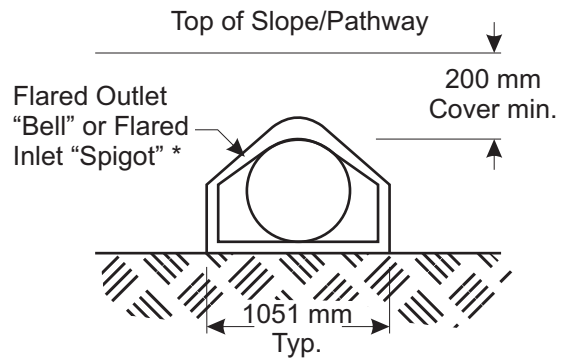

END VIEW

CITY OF CHESTERMERE
 Development & Infrastructure
 Services
 Parks Department



PR.0020.11
 January, 2015

SHEET TITLE:
 Pathway
 - Culvert & Edge Detail -

**LANDSCAPE STANDARDS &
 SPECIFICATIONS**

SHEET NO: COCH-LS 50
DRAWN BY: CB
DATE: 2013Sept
SCALE: N.T.S.

*Units are in millimetres unless
 otherwise noted.*

*Source: City of Calgary Standard
 Specifications for Landscape
 Construction, 2013.*

LEGEND & REFERENCES:

* Or approved equivalent.

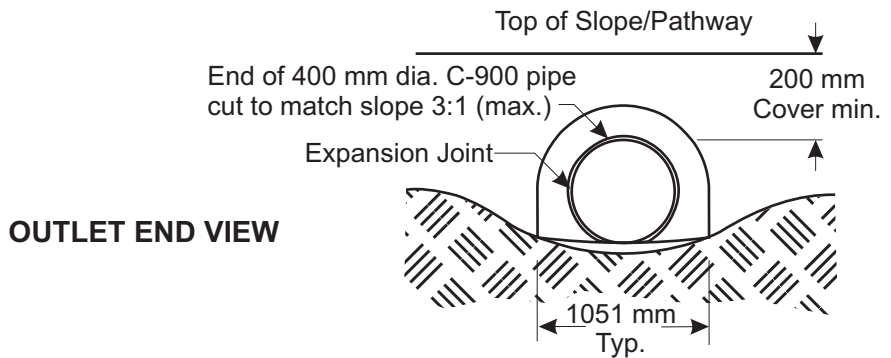
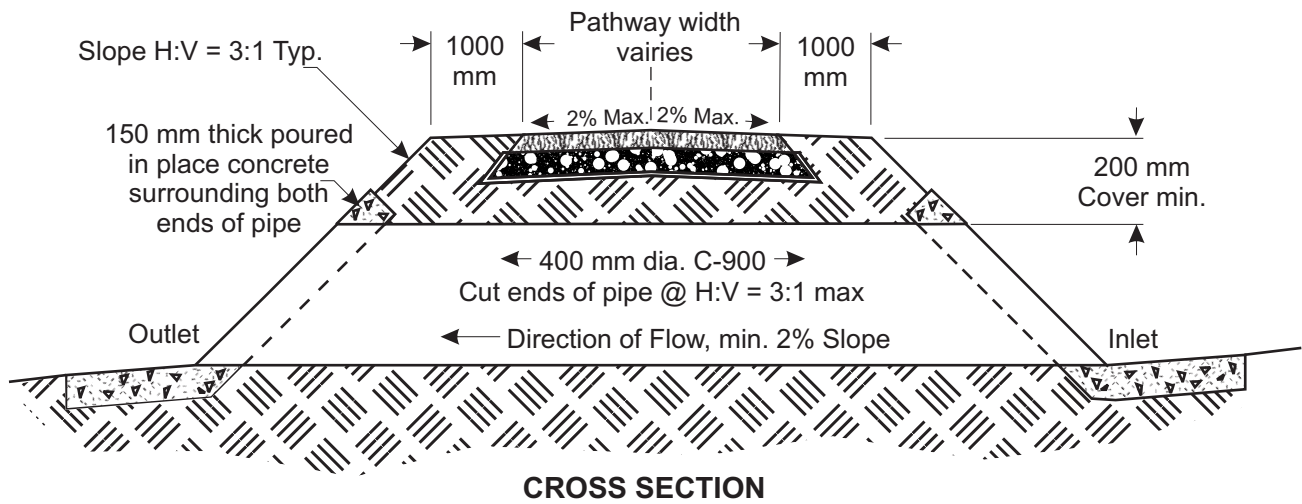
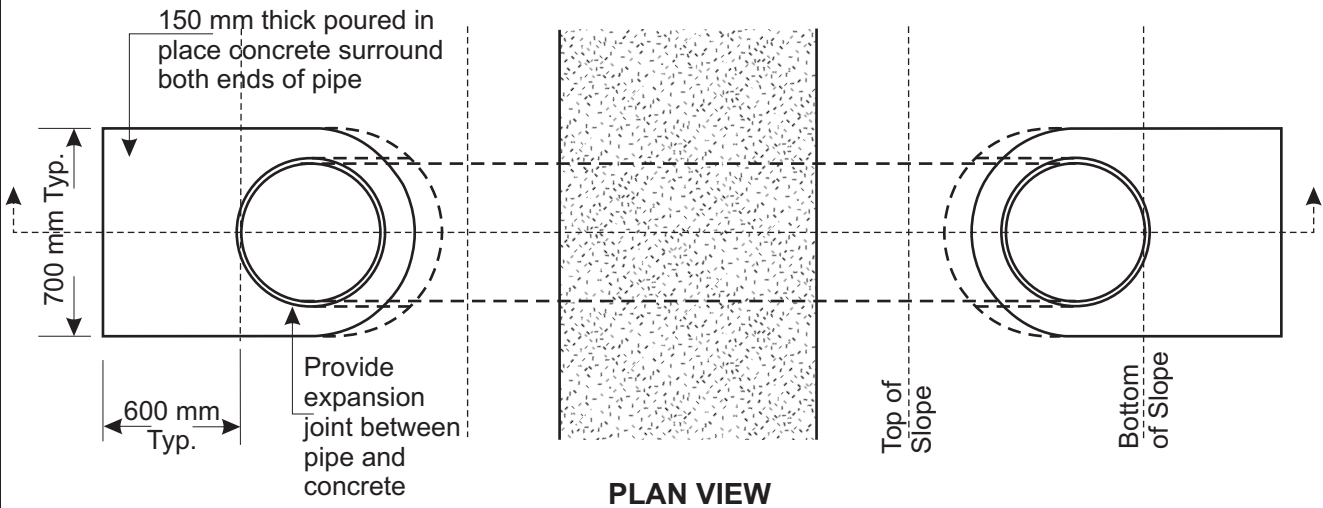

CITY OF CHESTERMERE
Development & Infrastructure
Services
Parks Department



PR.0020.11
January, 2015

SHEET TITLE:

Pathway
- P-I-P Concrete Ends -

**LANDSCAPE STANDARDS &
SPECIFICATIONS**

SHEET NO: COCH-LS 51

DRAWN BY: CB

DATE: 2013Sept

SCALE: N.T.S.

*Units are in millimetres unless
otherwise noted.*

*Source: City of Calgary Standard
Specifications for Landscape
Construction, 2013.*

LEGEND & REFERENCES:

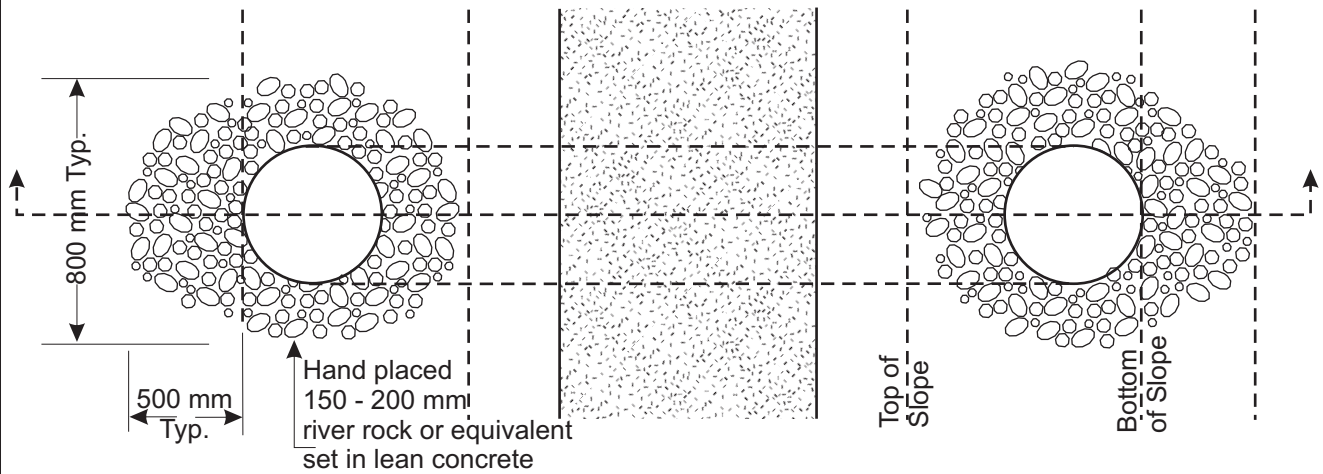

PLAN VIEW

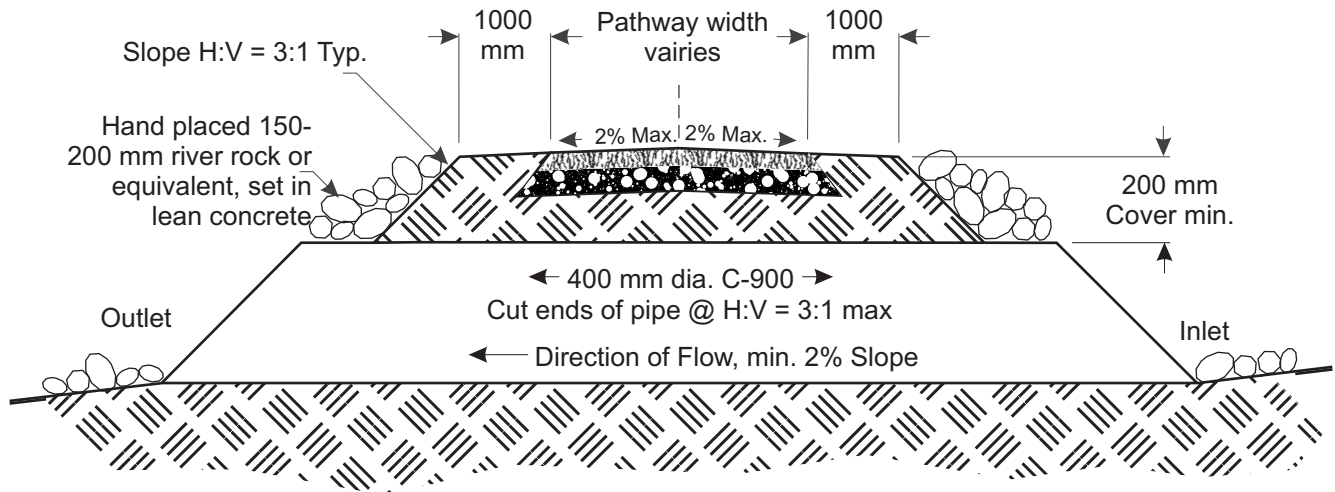

CROSS SECTION

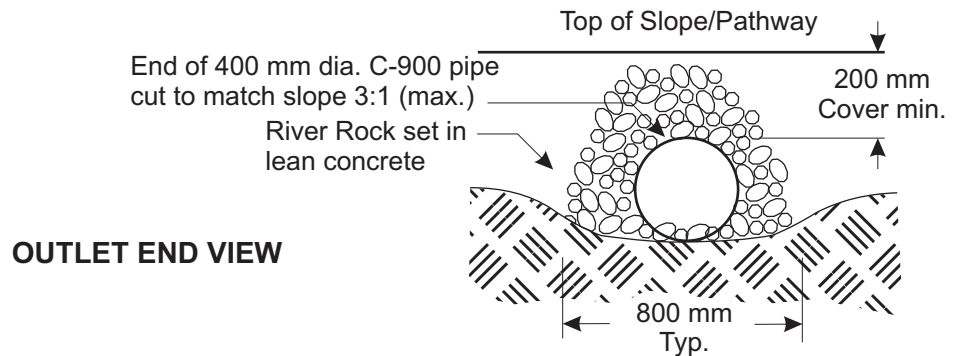

OUTLET END VIEW

CITY OF CHESTERMERE
 Development & Infrastructure
 Services
 Parks Department



PR.0020.11
 January, 2015

SHEET TITLE:
 Culvert
 - River Rock Ends -

LANDSCAPE STANDARDS & SPECIFICATIONS

SHEET NO:	COCH-LS 52
DRAWN BY:	CB
DATE:	2013Sept
SCALE:	N.T.S.
Units are in millimetres unless otherwise noted.	
Source: City of Calgary Standard Specifications for Landscape Construction, 2013.	

LEGEND & REFERENCES:

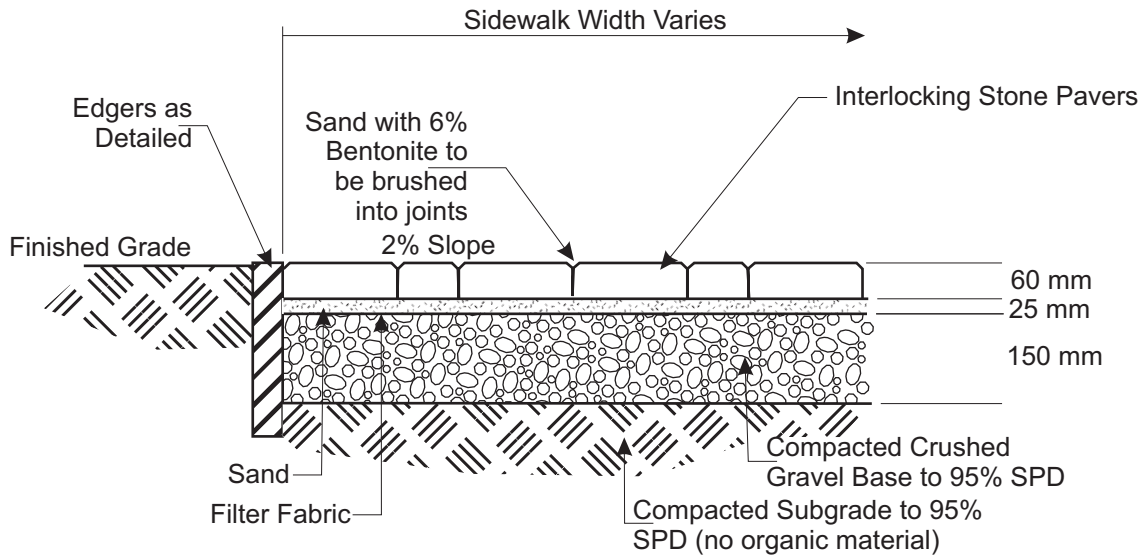

AREAS NOT SUBJECT TO VEHICLE TRAFFIC

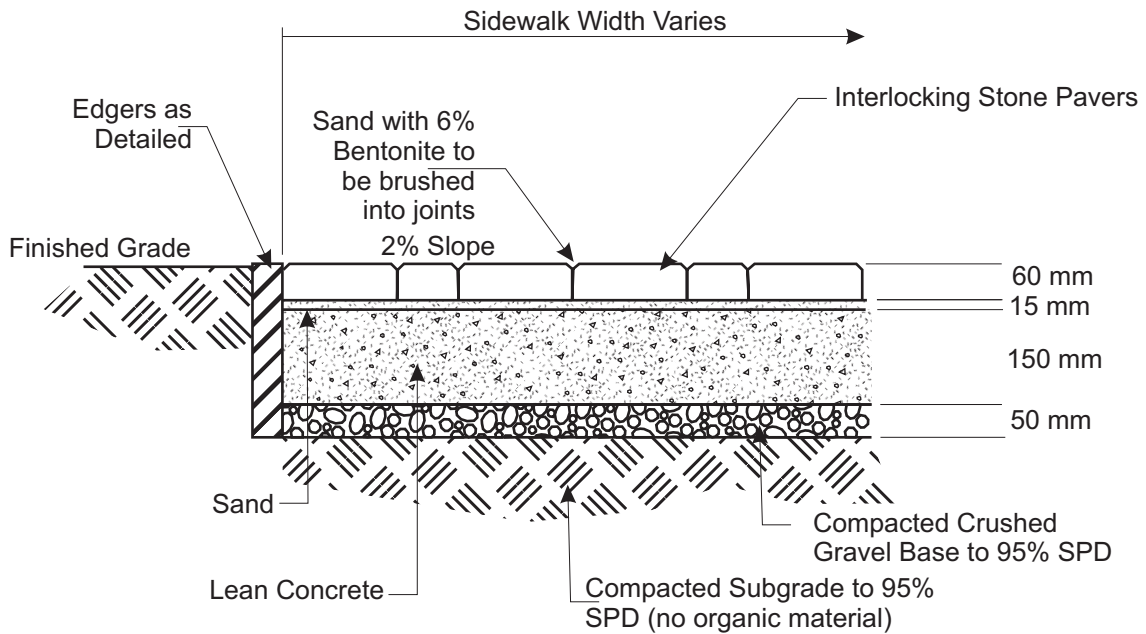

AREAS SUBJECT TO VEHICLE TRAFFIC AND AREAS WITHIN THE STREET RIGHT-OF-WAY

CITY OF CHESTERMERE
 Development & Infrastructure
 Services
 Parks Department



PR.0020.11
 January, 2015

SHEET TITLE:
 Concrete Paving Stone

LANDSCAPE STANDARDS & SPECIFICATIONS

SHEET NO: COCH-LS 53
DRAWN BY: CB
DATE: 2013Sept
SCALE: N.T.S.

Units are in millimetres unless otherwise noted.

Source: City of Calgary Standard Specifications for Landscape Construction, 2013.

LEGEND & REFERENCES:

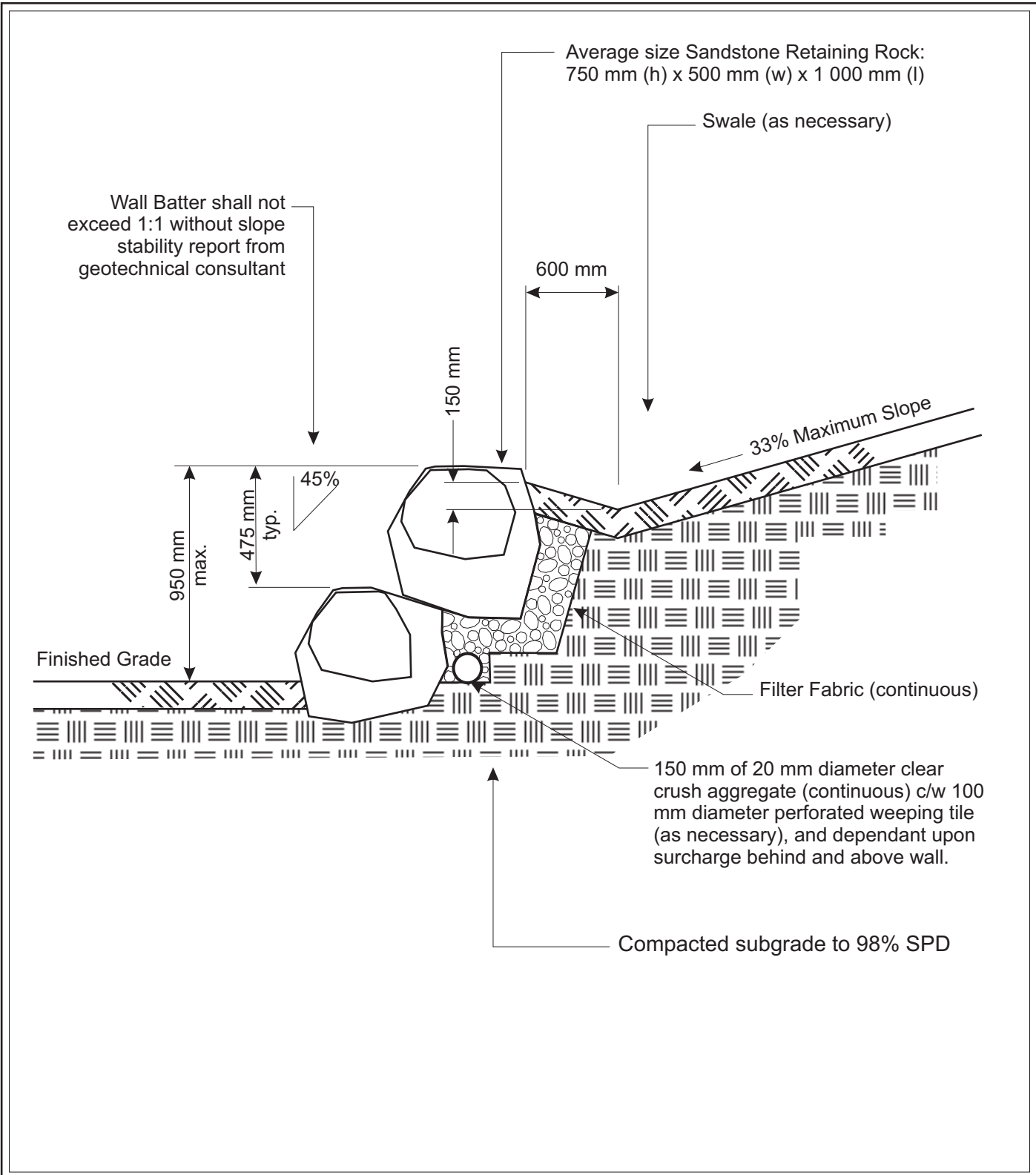

CITY OF CHESTERMERE
Development & Infrastructure Services
Parks Department



PR.0020.11
January, 2015

SHEET TITLE:

Retaining Wall
- Dry Pack Rock -

LANDSCAPE STANDARDS & SPECIFICATIONS

SHEET NO:	COCH-LS 55
DRAWN BY:	CB
DATE:	2013Sept
SCALE:	N.T.S.
<i>Units are in metres unless otherwise noted.</i>	
<i>Source: City of Calgary Standard Specifications for Landscape Construction, 2013.</i>	

LEGEND & REFERENCES:

1. All void spaces to be filled with clear crushed aggregate and consolidated to prevent migration of fill materials.
2. All rocks to be structurally sound; free of any spalling, cracks, crevices or splinters.
3. Mud stone is not acceptable.
4. All rocks to be buried 1/3 depth into ground. Place rocks to facilitate slope stability.
5. Wall shall conform to all current applicable legislation.

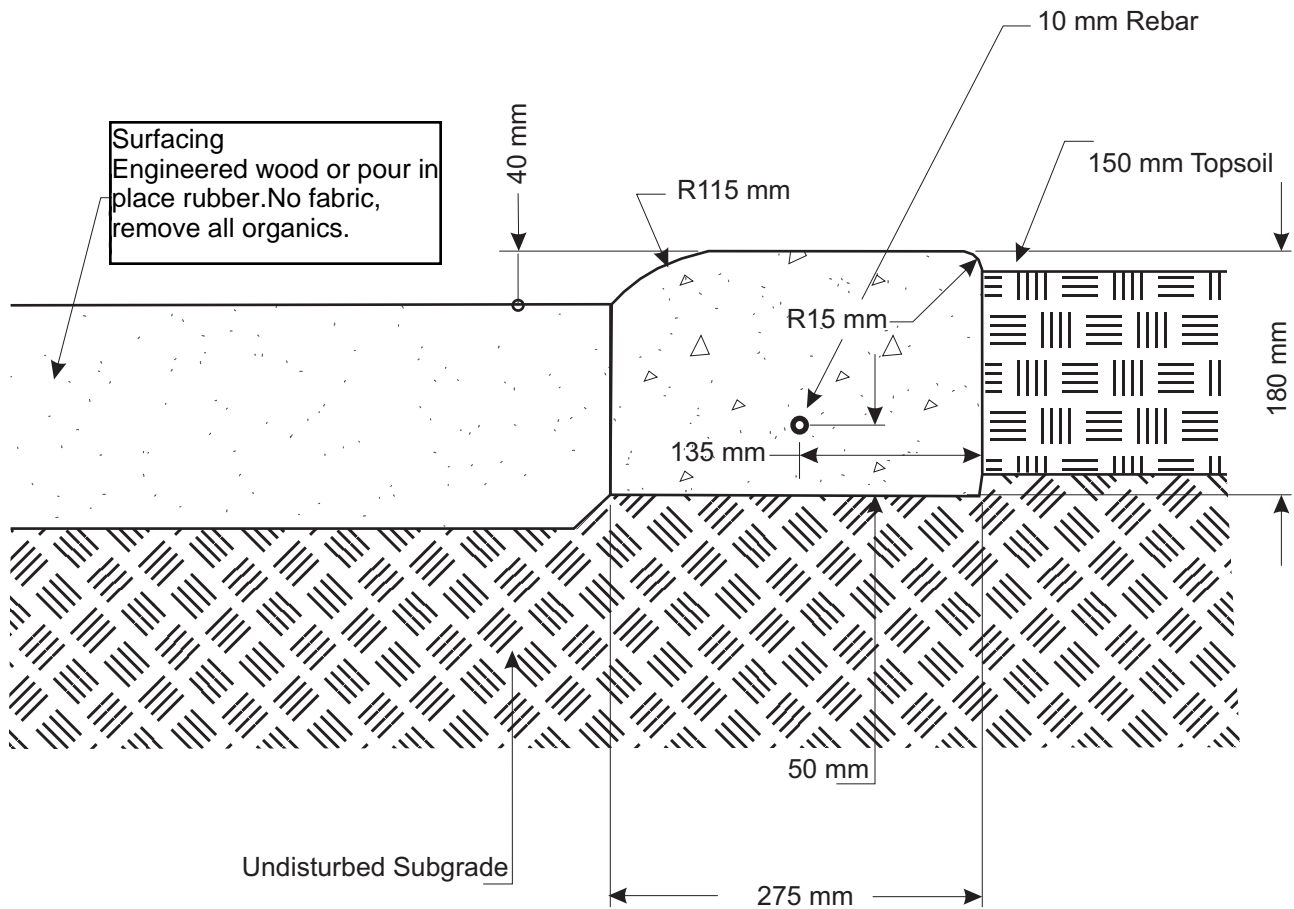

CITY OF CHESTERMERE
Development & Infrastructure
Services
Parks Department



PR.0020.11
January, 2015

SHEET TITLE:
Playground
- Concrete Edge Restraint -

LANDSCAPE STANDARDS & SPECIFICATIONS

SHEET NO:	COCH-LS 58
DRAWN BY:	CB
DATE:	2013Sept
SCALE:	N.T.S.

Units are in millimetres unless otherwise noted.

Source: City of Calgary Standard Specifications for Landscape Construction, 2013.

LEGEND & REFERENCES:

1. Contraction Joints shall be cut at every 1.5 m by means of a marking tool or other approved method. Joints shall not be less than 30 mm in depth and 6 mm in width. The edges of the joint shall be rounded off with an edger having a radius of 6 mm.

CONCRETE CURB

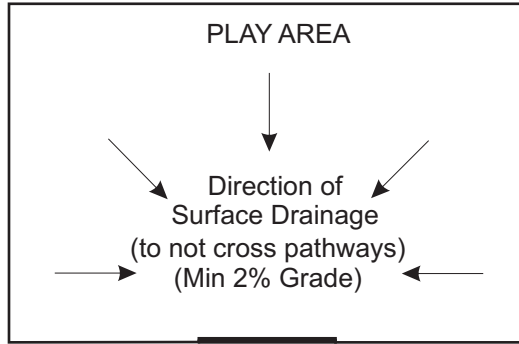

Surfacing
Engineered wood or pour in place rubber. No fabric, remove all organics.

See Detail(s) Below

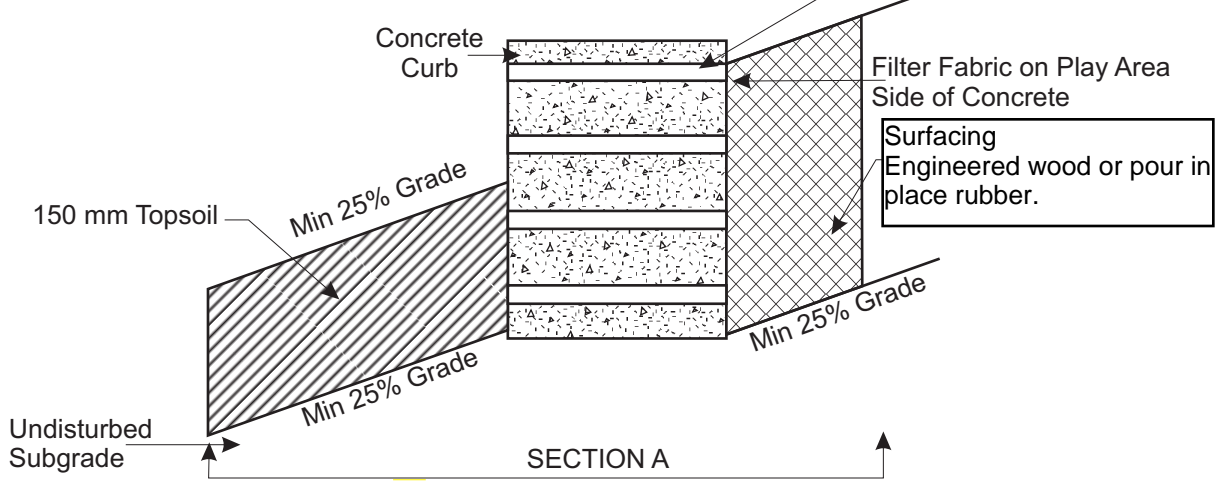
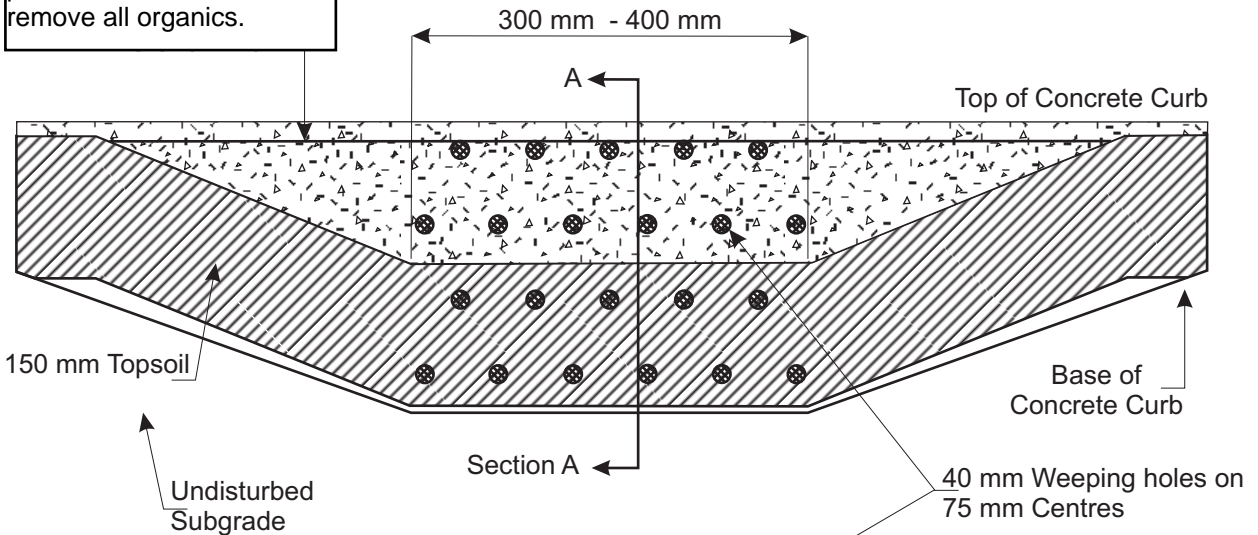

CITY OF CHESTERMERE
Development & Infrastructure Services
Parks Department



PR.0020.11
January, 2015

SHEET TITLE:
Playground Drainage
- Concrete Edge Detail -

LANDSCAPE STANDARDS & SPECIFICATIONS

SHEET NO:	COCH-LS 59
DRAWN BY:	CB
DATE:	2013Sept
SCALE:	N.T.S.

Units are in millimetres unless otherwise noted.

Source: City of Calgary Standard Specifications for Landscape Construction, 2013.

LEGEND & REFERENCES:

Elevation

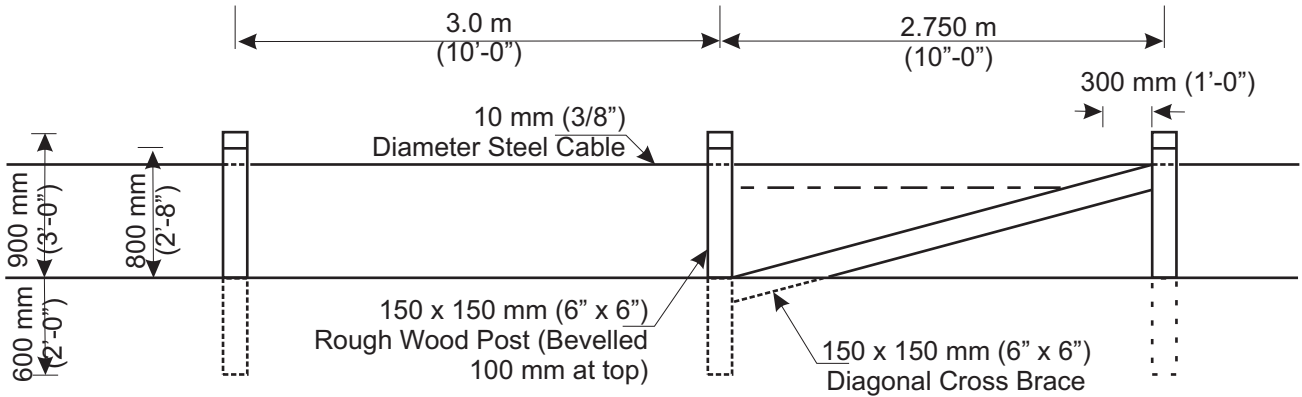

Post Top Detail

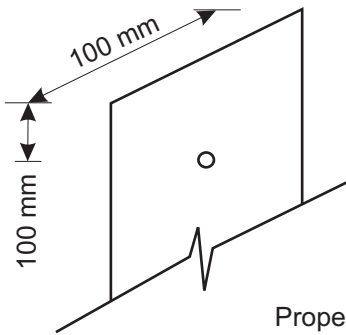

Plan View (End Post)

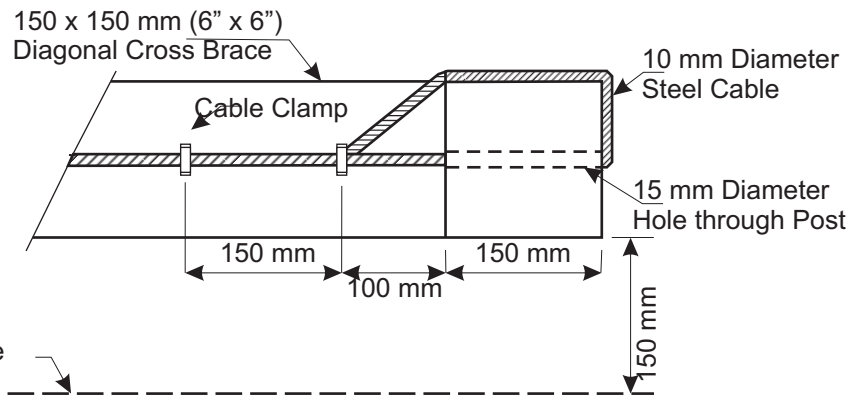

CITY OF CHESTERMERE

Development & Infrastructure
Services
Parks Department



PR.0020.11
January, 2015

SHEET TITLE:

Post & Cable Barrier

**LANDSCAPE STANDARDS &
SPECIFICATIONS**

SHEET NO: COCH-LS 63

DRAWN BY: CB

DATE: 2013Aug

SCALE: N.T.S.

*Units are in millimetres unless
otherwise noted.*

*Source: City of Calgary Standard
Specifications for Landscape
Construction, 2013.*

LEGEND & REFERENCES:

1. All lumber shall be rough cut. No. 2 construction grade and kiln dried.
2. The direction of the face cut will be specified on site when the posts are installed.
3. All steel cables and clamps shall be hot-dipped galvanized to CSA G 164 or as specified. Provide sufficient tension on steel cable to eliminate sag.
4. The first cable clamps will be located at the end of the cable to eliminate frayed ends.
5. Alternate Material: Where specified in contract. Wood Posts may be substituted with grey recycled plastic posts. All dimensions to remain the same.

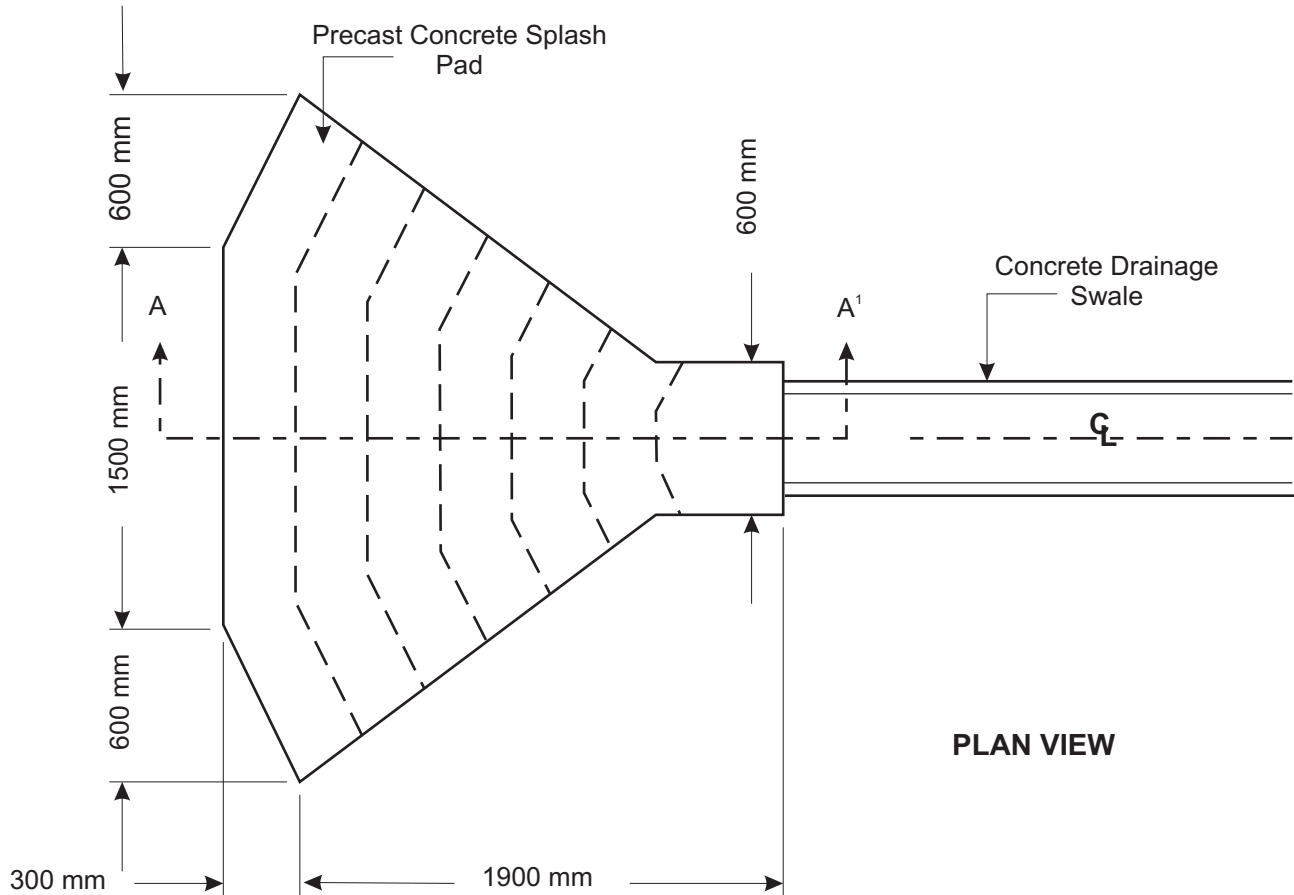

PLAN VIEW

Centre Lines of Energy Dispersion Bumps
@ 300 mm O.C.

Three (3) threaded inserts @ 150
mm to accept threaded 10M Bar

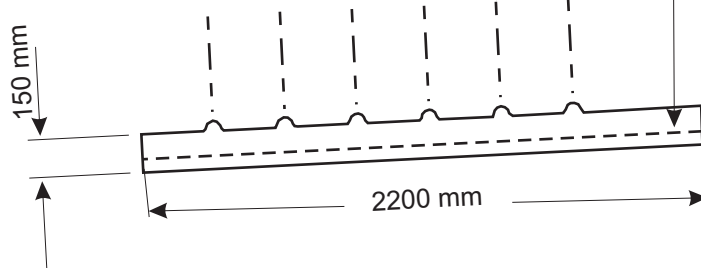

SECTION A - A¹

CITY OF CHESTERMERE
Development & Infrastructure
Services
Parks Department



PR.0020.11
January, 2015

SHEET TITLE:

Concrete Splash Pads
- On Public Easements -

**LANDSCAPE STANDARDS &
SPECIFICATIONS**

SHEET NO: COCH-LS 64

DRAWN BY: CB

DATE: 2013Sept

SCALE: N.T.S.

*Units are in millimetres unless
otherwise noted.*

*Source: City of Calgary Standard
Specifications for Landscape
Construction, 2013.*

LEGEND & REFERENCES:

1. 25 Mpa Concrete
2. Reinforcing all 10m Bar
3. Total Weight = 1207 kg
4. Concrete Splash Pads shall be min 2% installed at a 10% pitch, or erosion control fabric will be required at their end.
5. Industry may use variable concrete splash pad sizes subject to the velocity not exceeding 0.9 m/sec.
6. Subject to approval by Landscape Technician, other ECP/energy dispersion products may be used.
7. Rip Rap may be considered in Natural Areas.

Plan

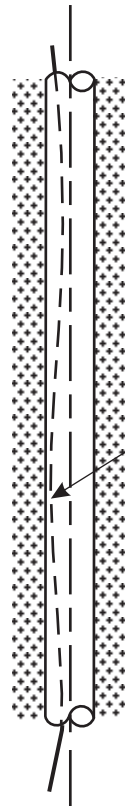

Snake Wire to Allow Contraction

TOG

As Specified

Section

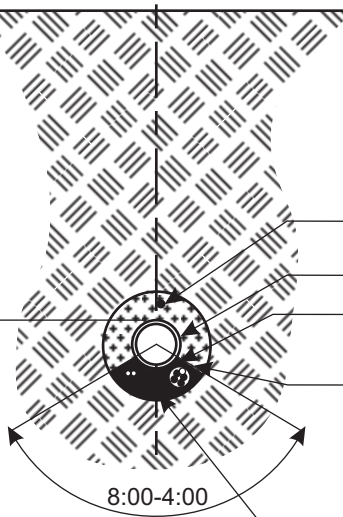

Green Colour 14 GA Trace Wire

Mainline/Lateral Pipe
Provide 25 mm Clearance
between Wire and Pipe

Specified 24VAC Valve Wire Bundle

8:00-4:00

Specified Communication Wire

CITY OF CHESTERMERE

Development & Infrastructure
Services
Parks Department



PR.0020.11
January, 2015

SHEET TITLE:

Irrigation Field Wire Alignment

LANDSCAPE STANDARDS &
SPECIFICATIONS

SHEET NO: COCH-LS 67

DRAWN BY: CB

DATE: 2013Dec

SCALE: N.T.S.

All dimensions are in metres unless
otherwise specified.

Source: City of Calgary Standard
Specifications for Landscape
Construction, 2013.

LEGEND & REFERENCES:

Specified 24VAC Valve Wire
Bundle c/w:
* 2 Spare Wire/5 zones w/300 mm
spare loop @ valve box

Specified Communication Wire:
* For irrigation Sensors +
Controllers
* Shielded polyethylene sleeve

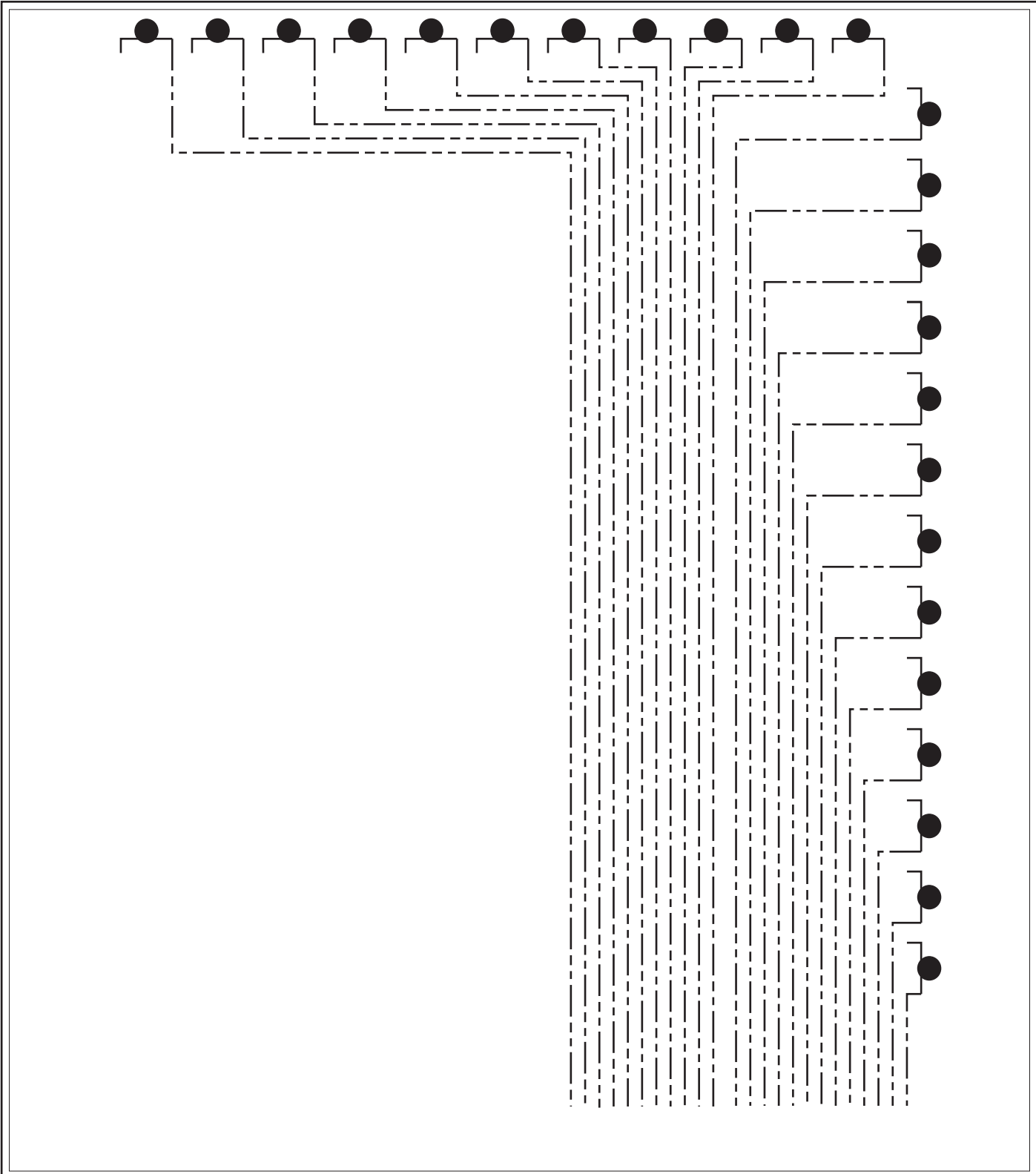

CITY OF CHESTERMERE
 Development & Infrastructure
 Services
 Parks Department





PR.0020.11
 January, 2015

SHEET TITLE:
 Electric Control Valve Signal
 Wire Schematic

**LANDSCAPE STANDARDS &
 SPECIFICATIONS**

SHEET NO:	COCH-LS 68
DRAWN BY:	CB
DATE:	2013Dec
SCALE:	N.T.S.
<i>Source: City of Calgary Standard Specifications for Landscape Construction, 2013.</i>	

LEGEND & REFERENCES:

-  Mainline
-  Signal Wire
-  Electric Control Valve

Install one (1) signal wire per valve.

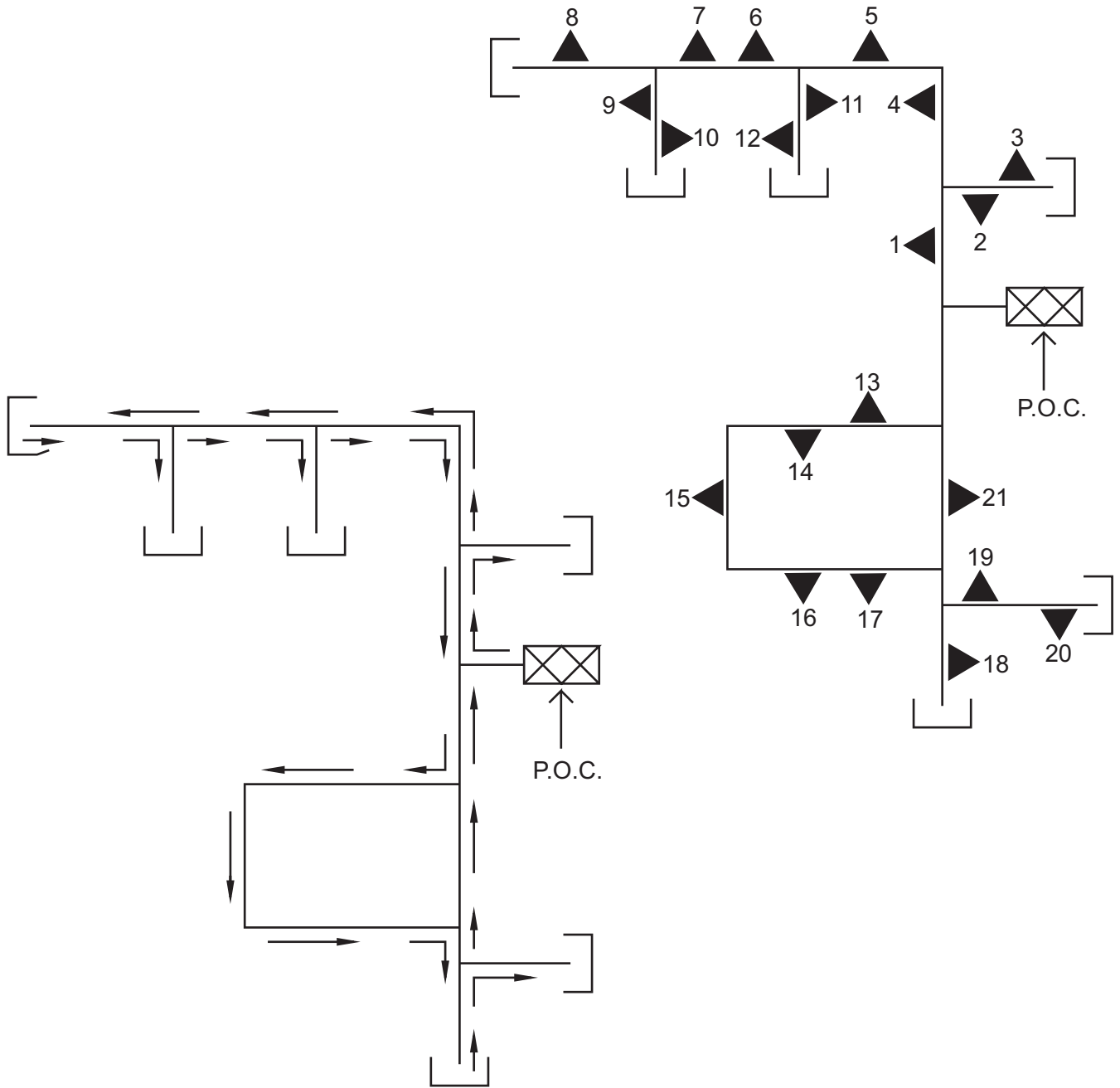

CITY OF CHESTERMERE
 Development & Infrastructure
 Services
 Parks Department



PR.0020.11
 January, 2015

SHEET TITLE:
 Right Hand Valve Wiring Rule

LANDSCAPE STANDARDS & SPECIFICATIONS

SHEET NO:	COCH-LS 69
DRAWN BY:	CB
DATE:	2013Dec
SCALE:	N.T.S.
<p><i>Source: City of Calgary Standard Specifications for Landscape Construction, 2013.</i></p>	

LEGEND & REFERENCES:

P.O.C. - Point of Connection

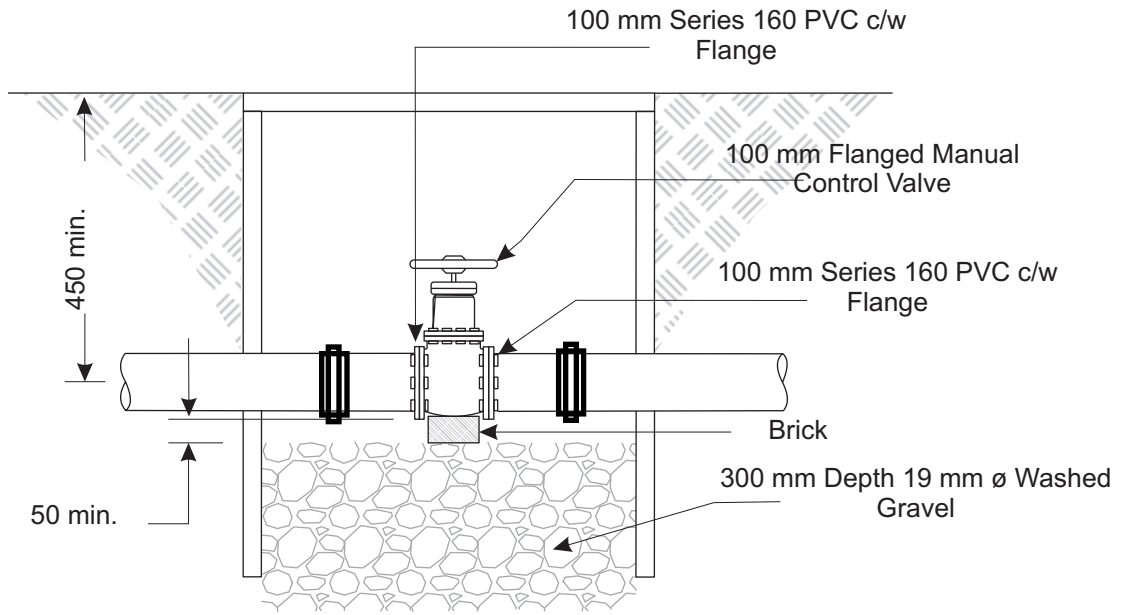

Elevation

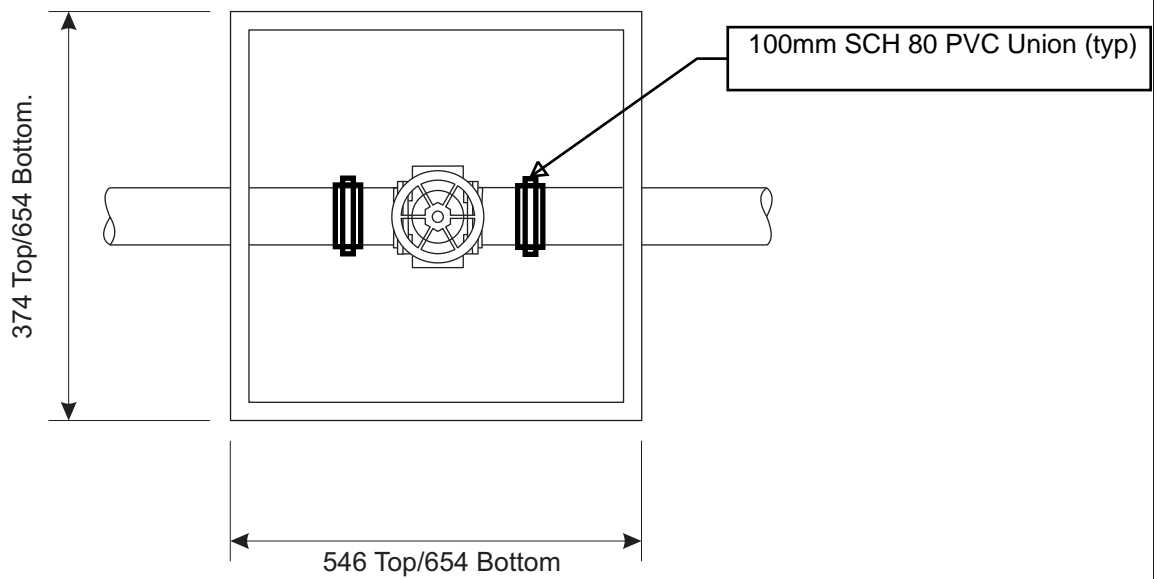

Plan

CITY OF CHESTERMERE
 Development & Infrastructure
 Services
 Parks Department



PR.0020.11
 January, 2015

SHEET TITLE:
 Isolation Valve Main Control
 Valve (PVC)
 - 100 mm -

**LANDSCAPE STANDARDS &
 SPECIFICATIONS**

SHEET NO:	COCH-LS 72
DRAWN BY:	CB
DATE:	2013Dec
SCALE:	N.T.S.

All dimensions are in millimetres unless otherwise specified.

Source: City of Calgary Standard Specifications for Landscape Construction, 2013.

LEGEND & REFERENCES:

All bolt heads on flanges shall be facing away from valve.

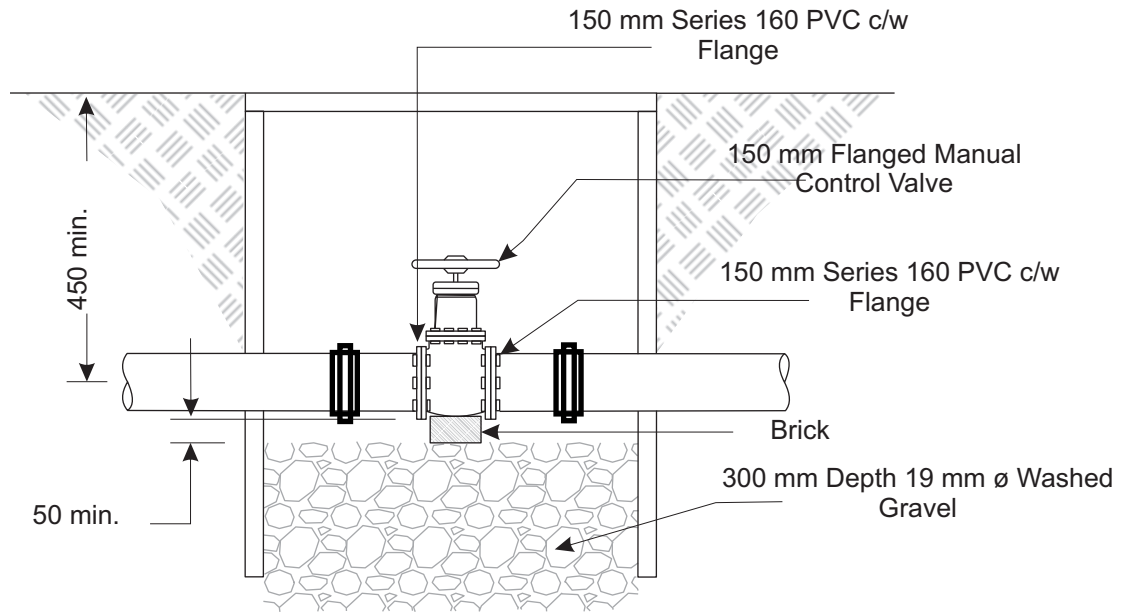

Elevation

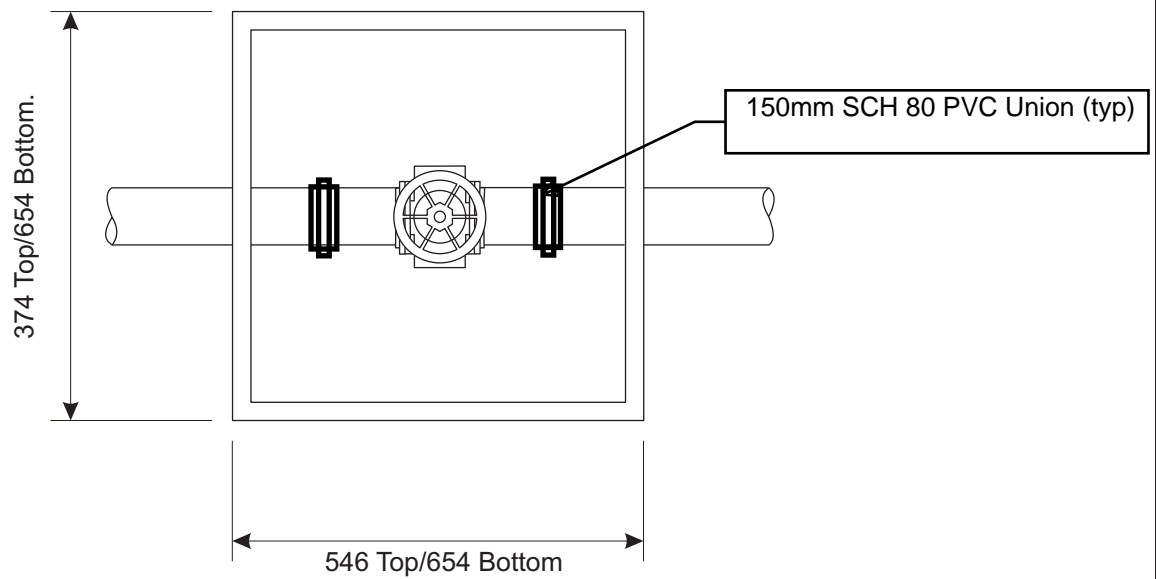

Plan

CITY OF CHESTERMERE
 Development & Infrastructure
 Services
 Parks Department



PR.0020.11
 January, 2015

SHEET TITLE:
 Isolation Valve Main Control
 Valve (PVC)
 - 150 mm -

LANDSCAPE STANDARDS & SPECIFICATIONS

SHEET NO:	COCH-LS 73
DRAWN BY:	CB
DATE:	2013Dec
SCALE:	N.T.S.

All dimensions are in millimetres unless otherwise specified.

Source: City of Calgary Standard Specifications for Landscape Construction, 2013.

LEGEND & REFERENCES:

All bolt heads on flanges shall be facing away from valve.

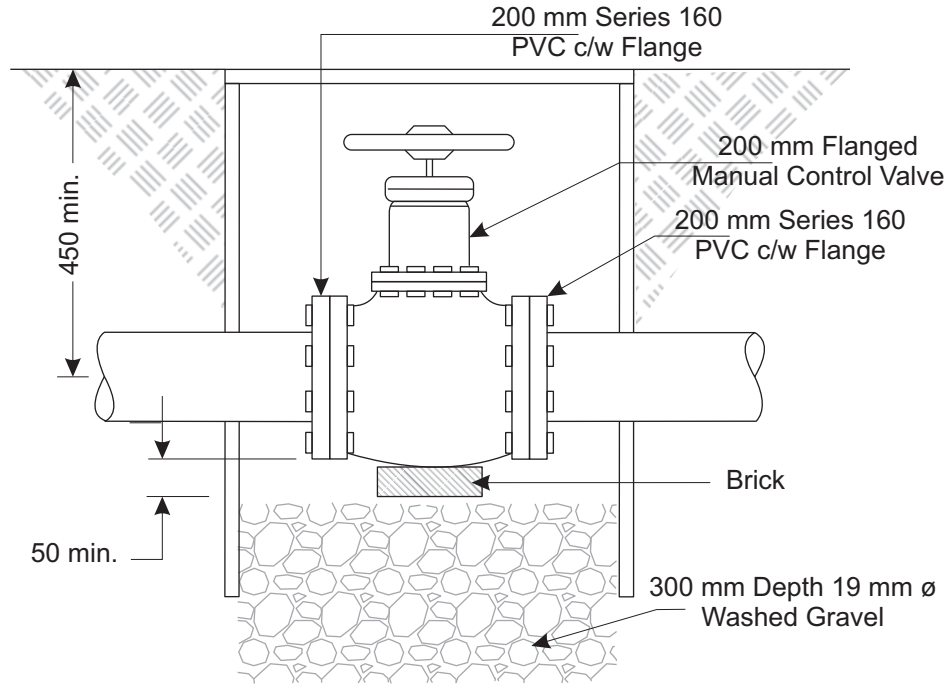

Elevation

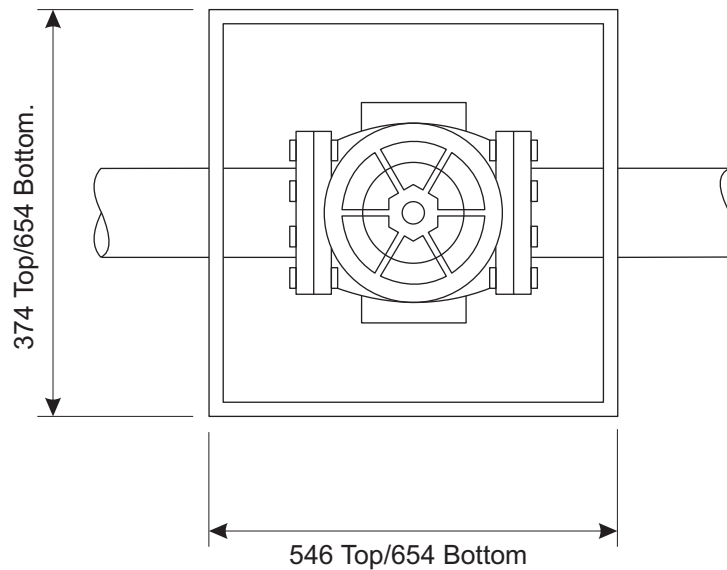

Plan

CITY OF CHESTERMERE
Development & Infrastructure
Services
Parks Department



PR.0020.11
January, 2015

SHEET TITLE:
Isolation Valve Main Control
Valve (PVC)
- 200 mm -

**LANDSCAPE STANDARDS &
SPECIFICATIONS**

SHEET NO:	COCH-LS 74
DRAWN BY:	CB
DATE:	2013Dec
SCALE:	N.T.S.

All dimensions are in millimetres
unless otherwise specified.

Source: City of Calgary Standard
Specifications for Landscape
Construction, 2013.

LEGEND & REFERENCES:

All bolt heads on flanges shall be
facing away from valve.

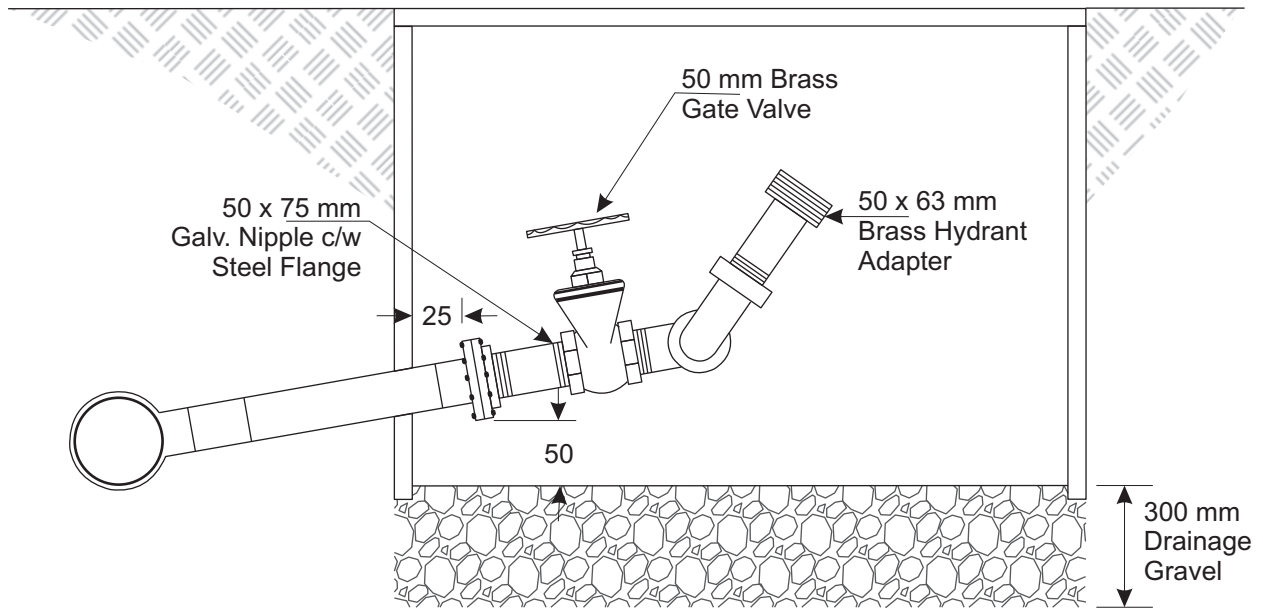

Elevation

CITY OF CHESTERMERE

Development & Infrastructure
Services
Parks Department



PR.0020.11
January, 2015

SHEET TITLE:

Compressor Connection
& Meter Test Assembly
- 50 mm -

**LANDSCAPE STANDARDS &
SPECIFICATIONS**

SHEET NO: COCH-LS 75

DRAWN BY: CB

DATE: 2014 Jan

SCALE: N.T.S.

All dimensions are in millimetres
unless otherwise specified.

Source: City of Calgary Standard
Specifications for Landscape
Construction, 2013.

LEGEND & REFERENCES:

1. Increase angle at elbow to allow for easier hose connection to adapter.

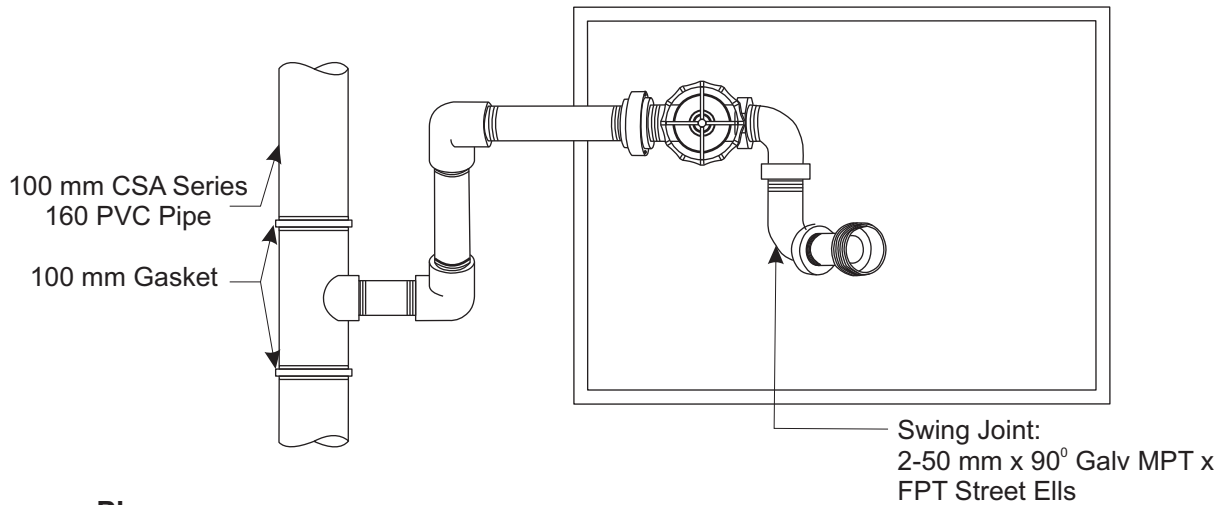

Plan

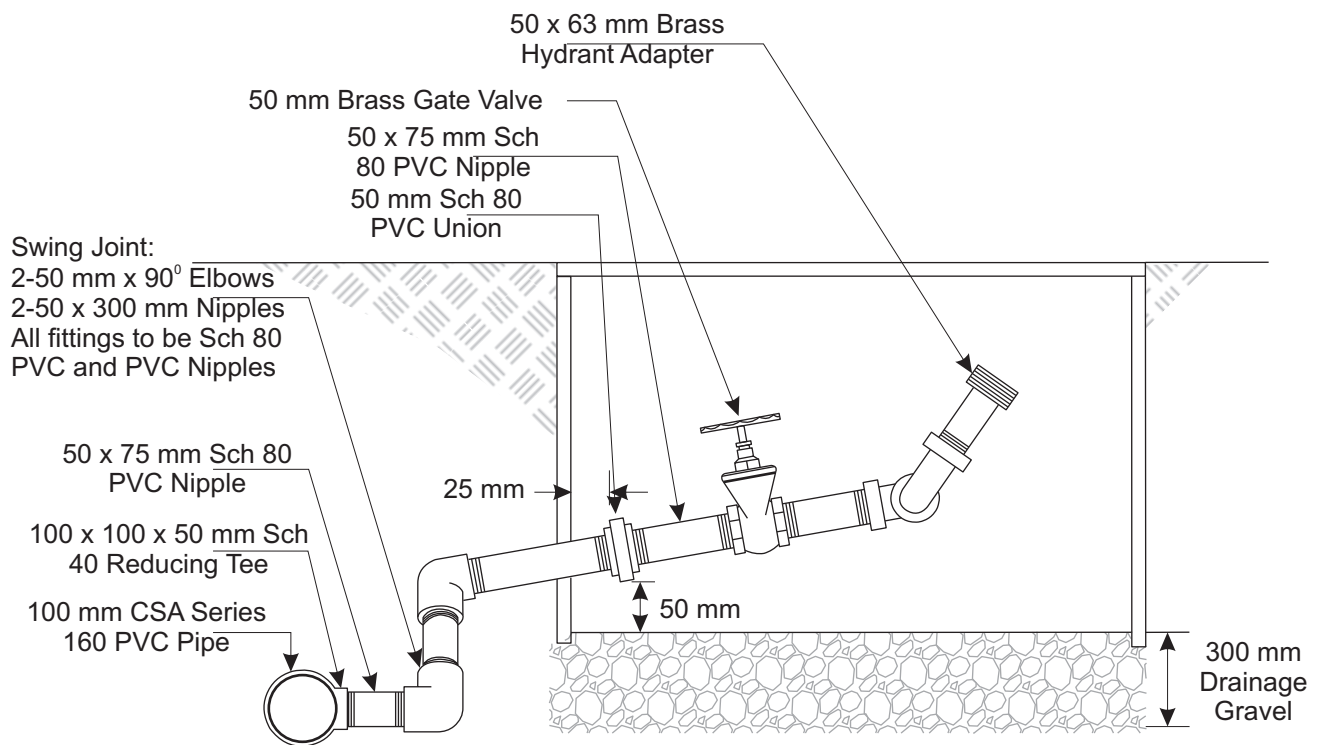

Section

CITY OF CHESTERMERE
Development & Infrastructure
Services
Parks Department



PR.0020.11
January, 2015

SHEET TITLE:
Field Gate Valve Assembly
- 50 mm -

LANDSCAPE STANDARDS & SPECIFICATIONS

SHEET NO:	COCH-LS 76
DRAWN BY:	CB
DATE:	2013Dec
SCALE:	N.T.S.

All dimensions are in millimetres unless otherwise specified.

Source: City of Calgary Standard Specifications for Landscape Construction, 2013.

LEGEND & REFERENCES:

Increase angle at elbow to allow for easier hose connection to adapter. Valve assembly may be used as future zone valve. Leave electrical wires for future electrical valve. Use pre-manufactured extensions when obtaining proper height of boxes.

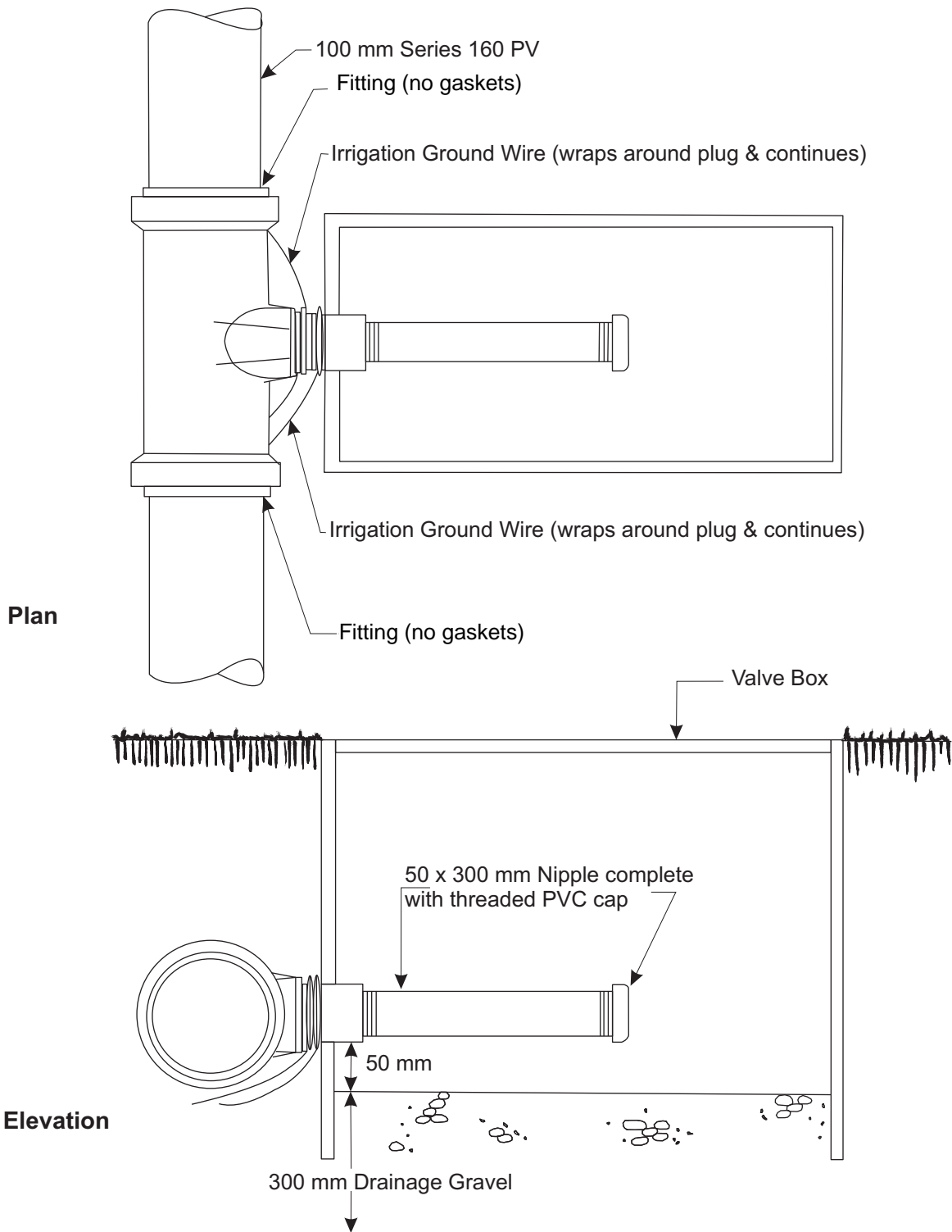

CITY OF CHESTERMERE
 Development & Infrastructure Services
 Parks Department



PR.0020.11
 January, 2015

SHEET TITLE:
 Tee Hook-Up

LANDSCAPE STANDARDS & SPECIFICATIONS

SHEET NO:	COCH-LS 77
DRAWN BY:	CB
DATE:	2013Dec
SCALE:	N.T.S.

All dimensions are in metres unless otherwise specified.

Source: City of Calgary Standard Specifications for Landscape Construction, 2013.

LEGEND & REFERENCES:

Box Specifications: (all outside measurements)

Bottom	482 mm x 654 mm
Top	374 mm x 546 mm
Height	304 mm

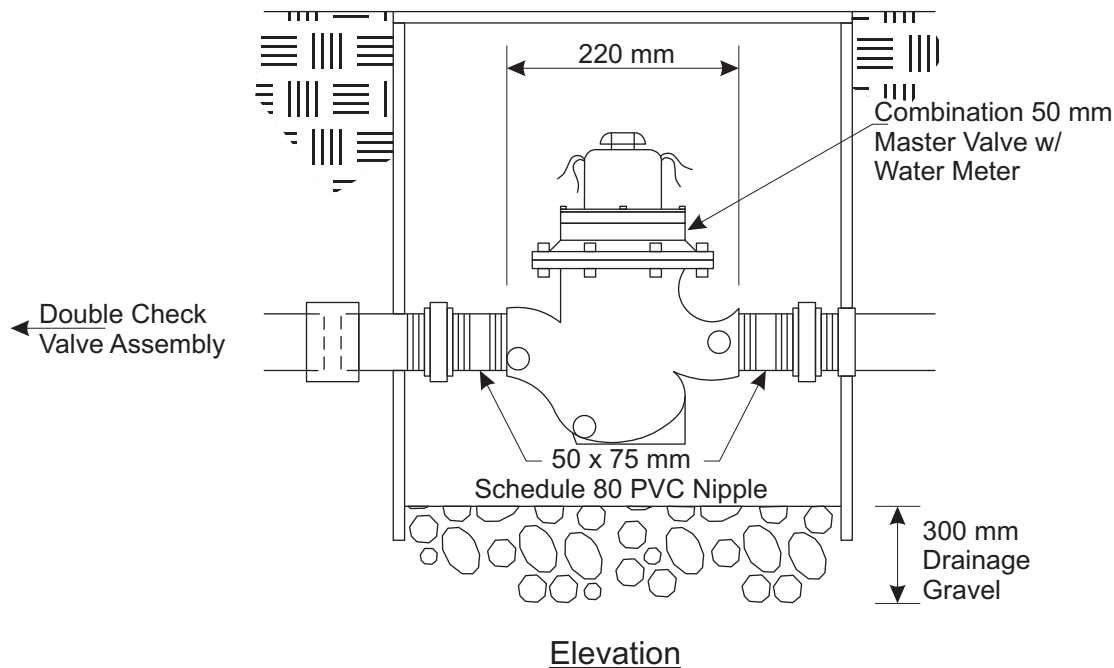
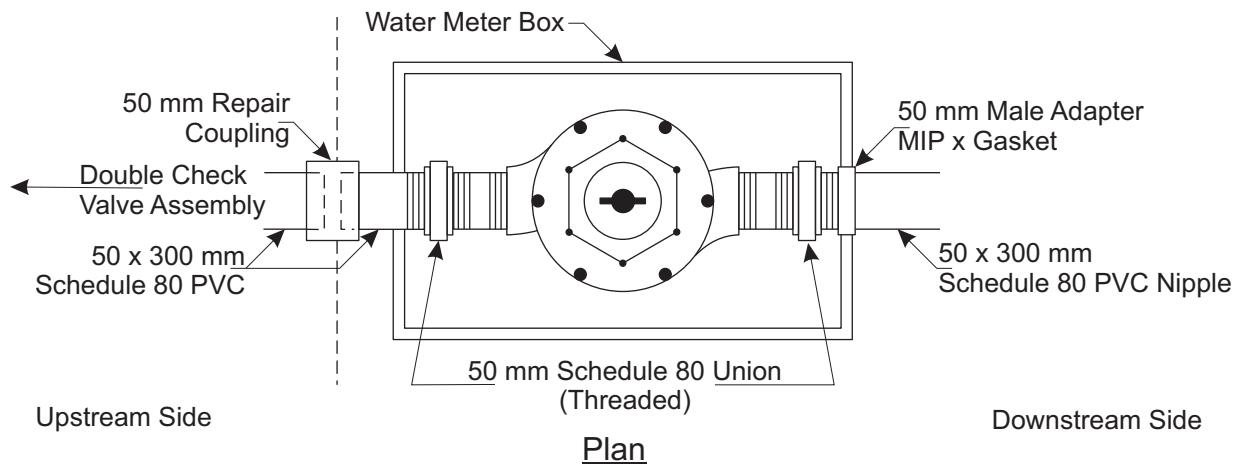

CITY OF CHESTERMERE
 Development & Infrastructure Services
 Parks Department



PR.0020.11
 January, 2015

SHEET TITLE:
 Valve Hook-Up (PVC)
 - 50 mm to 50 mm -
 (Combination 50 m Master Valve with Water Meter)

LANDSCAPE STANDARDS & SPECIFICATIONS

SHEET NO:	COCH-LS 78
DRAWN BY:	CB
DATE:	2013Jan
SCALE:	N.T.S.

All dimensions are in metres unless otherwise specified.

Source: *City of Calgary Standard Specifications for Landscape Construction, 2013.*

LEGEND & REFERENCES:

- Use premanufactured extensions when obtaining proper height of boxes.
- Eight-14 gauge direct burial wires to run from water meter to controller box.

Box Specifications: (all outside measurements)

Bottom	482 mm x 654 mm
Top	374 mm x 546 mm
Height	304 mm

- Install Quick Couple Valve 0.5 m downstream from the water meter box.
- Locate 1.5 m (center to center) downstream of double check valve box.
- All fittings on the pressure side are to be Schedule 80.

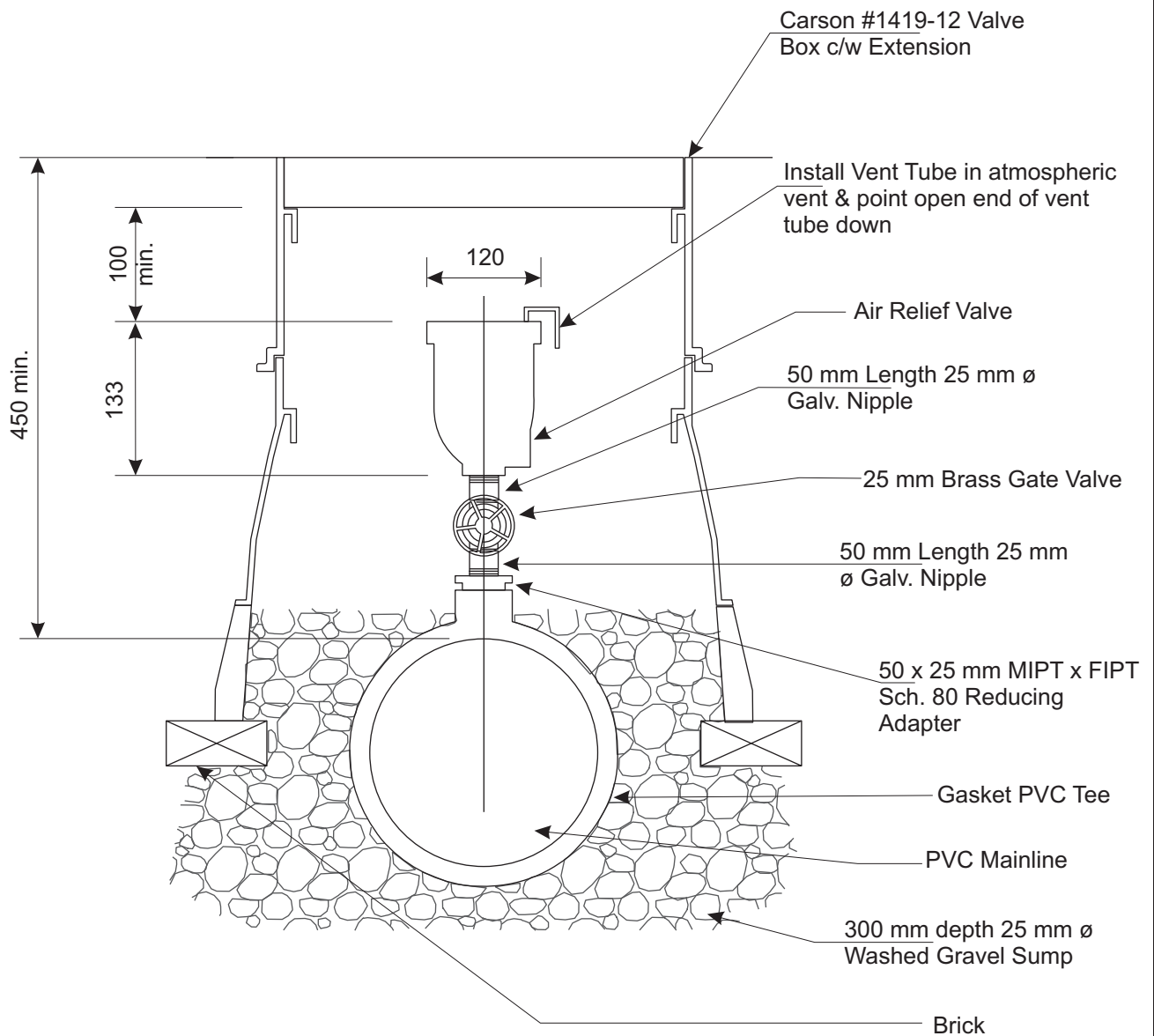

CITY OF CHESTERMERE

Development & Infrastructure
Services
Parks Department



PR.0020.11
January, 2015

SHEET TITLE:

Air Relief Valve
- PVC -

**LANDSCAPE STANDARDS &
SPECIFICATIONS**

SHEET NO: COCH-LS 79

DRAWN BY: CB

DATE: 2013Jan

SCALE: N.T.S.

All dimensions are in millimetres
unless otherwise specified.

Source: City of Calgary Standard
Specifications for Landscape
Construction, 2013.

LEGEND & REFERENCES:

1. Ensure mainline depth from top of pipe to finished grade is at minimum 450 mm.

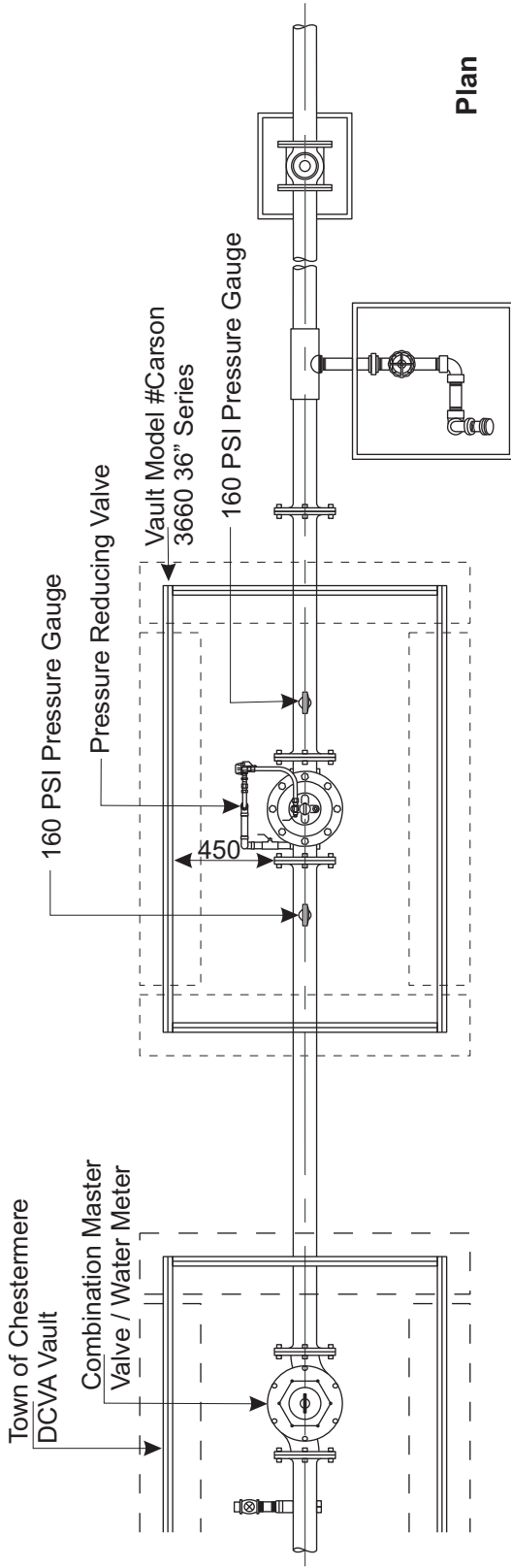

Plan

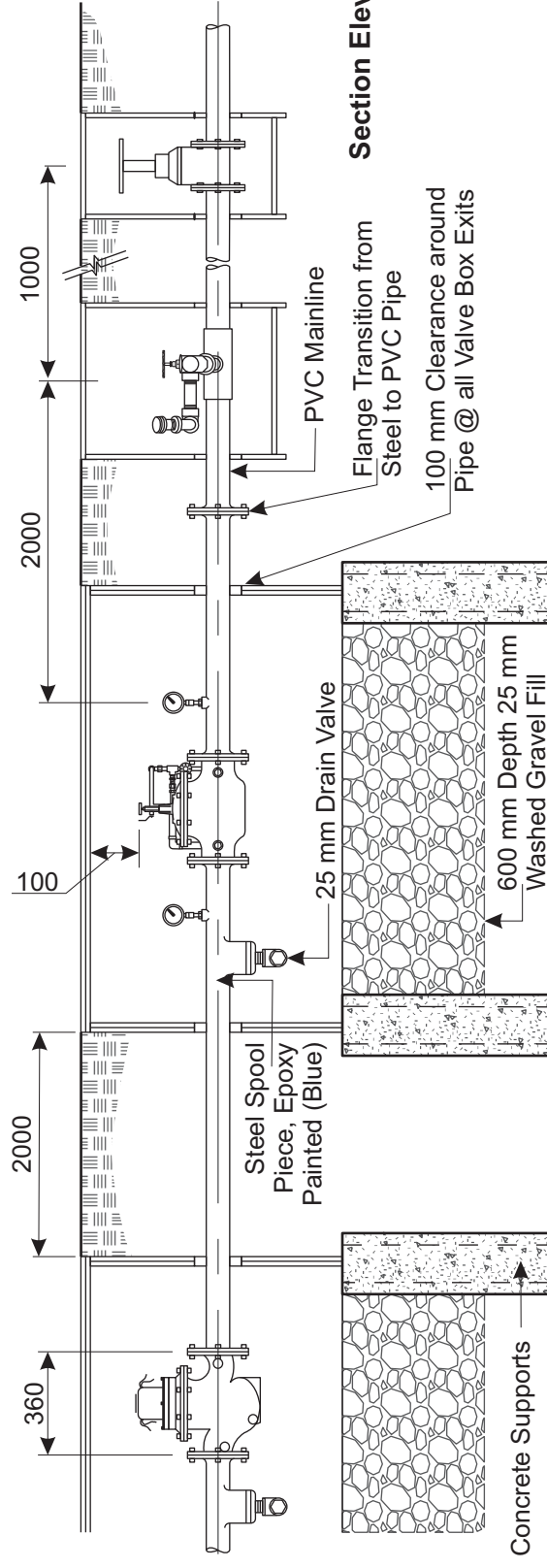

Section Elevation

SHEET NO:	COCH-LS 80	<i>Units are in metres unless otherwise noted.</i>	
DRAWN BY:	CB	DATE:	2014/Jan
SCALE:	N.T.S.	<i>Source: City of Calgary Standard Specifications for Landscape Construction, 2013.</i>	

- LEGEND & REFERENCES:**
- Where there is an irrigation mainline with 25 lm of a pedestrian entrance on irrigation turf valve shall be placed at that entrance.
 - Net Post and/or transom located 0.9144 m from edge of court.

SHEET TITLE:
Pressure Reducing Valve Assembly

PROJECT TITLE:
LANDSCAPE STANDARDS & SPECIFICATIONS

CITY OF CHESTERMERE
Development & Infrastructure Services
Parks Department

PR.0020.11
January, 2015



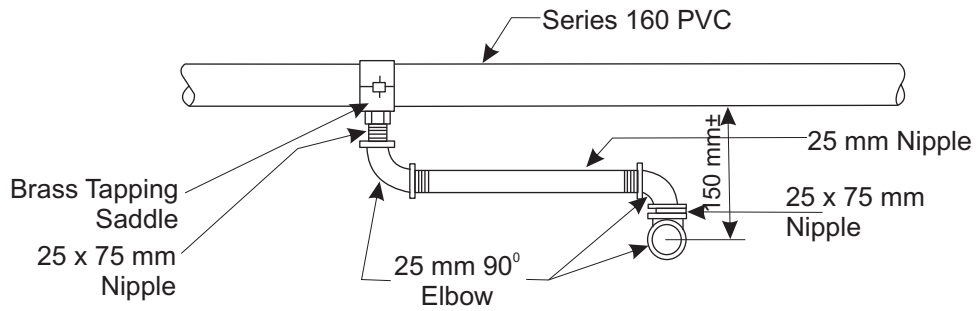

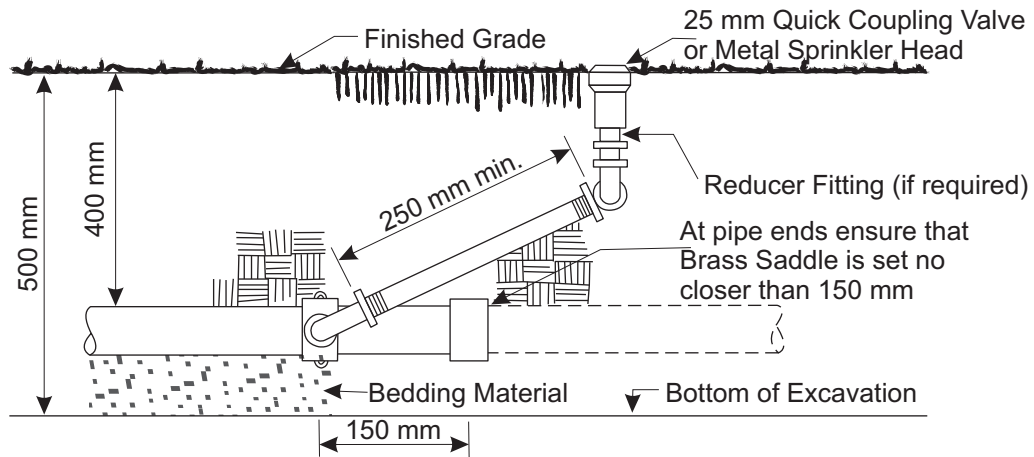

Plan View

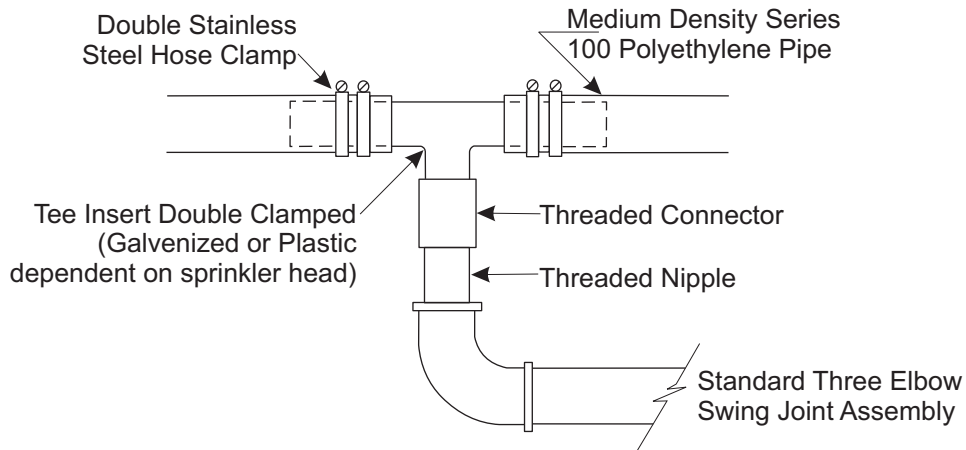

Elevation



CITY OF CHESTERMERE
 Development & Infrastructure Services
 Parks Department



PR.0020.11
 January, 2015

SHEET TITLE:
 Three Elbow Swing Joint
 - Metal Sprinkler Head -

LANDSCAPE STANDARDS & SPECIFICATIONS

SHEET NO:	COCH-LS 81
DRAWN BY:	CB
DATE:	2014 Jan
SCALE:	N.T.S.

All dimensions are in metres unless otherwise specified.

Source: City of Calgary Standard Specifications for Landscape Construction, 2013.

LEGEND & REFERENCES:

1. Install Swing Joint so that all water drains back into pipe.
2. Use galvanized fittings when installing Quick Coupling Valves or Metal Sprinkler Heads. Use Teflon Tape at all connections as per proper trade practice.
3. Use Schedule 40 PVC Fittings and Schedule 80 PVC Nipples when installing plastic sprinkler heads.

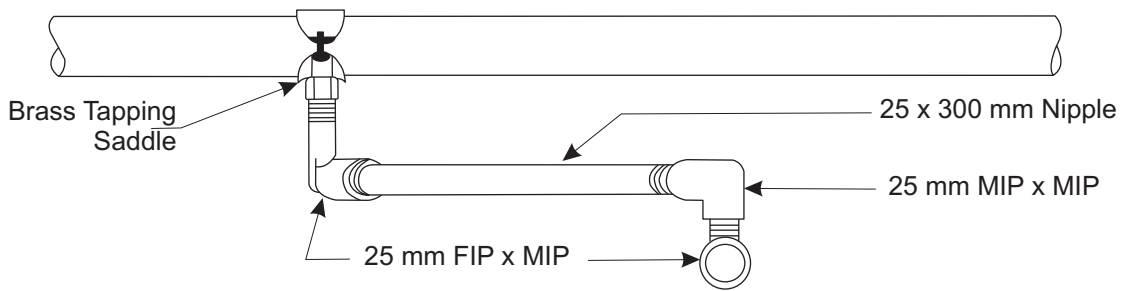

Plan View

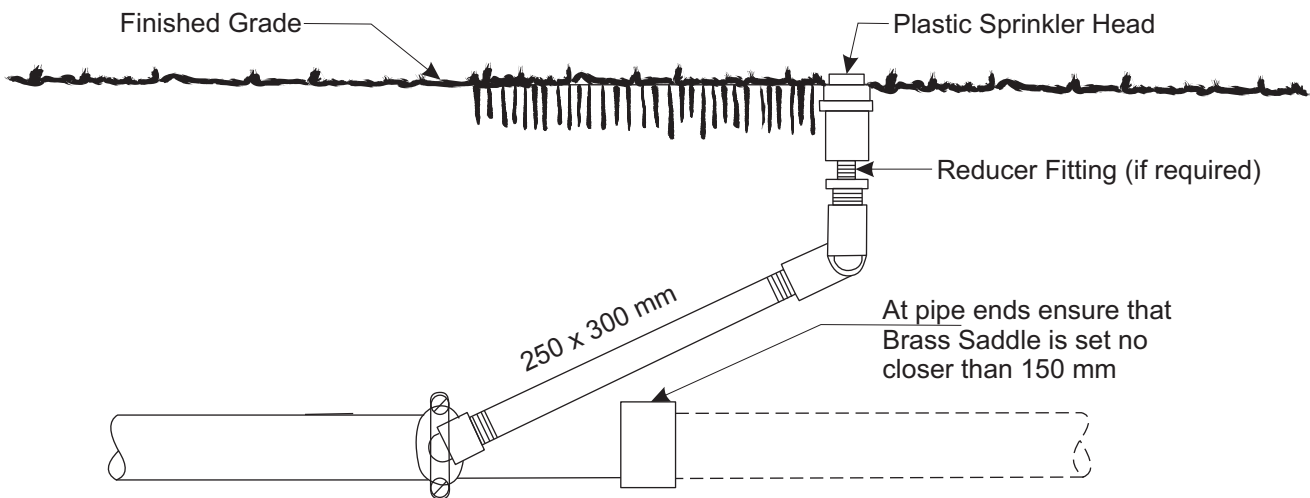

Elevation

<p>CITY OF CHESTERMERE Development & Infrastructure Services Parks Department</p>  <p>PR.0020.11 January, 2015</p>	<p>SHEET TITLE:</p> <p>Three Elbow Swing Joint - Plastic Sprinkler Head -</p>	<p>SHEET NO: COCH-LS 82</p>	<p>LEGEND & REFERENCES:</p> <ol style="list-style-type: none"> 1. Install Swing Joint so that all water drains back into pipe. 2. Use galvanized fittings when installing Quick Coupling Valves or Metal Sprinkler Heads. Use Teflon Tape at all connections as per proper trade practice. 3. Use Schedule 40 PVC Fittings and Schedule 80 PVC Nipples when installing plastic sprinkler heads.
	<p>LANDSCAPE STANDARDS & SPECIFICATIONS</p>	<p>DRAWN BY: CB</p> <p>DATE: 2014 Jan</p> <p>SCALE: N.T.S.</p> <p>All dimensions are in metres unless otherwise specified.</p> <p>Source: City of Calgary Standard Specifications for Landscape Construction, 2013.</p>	

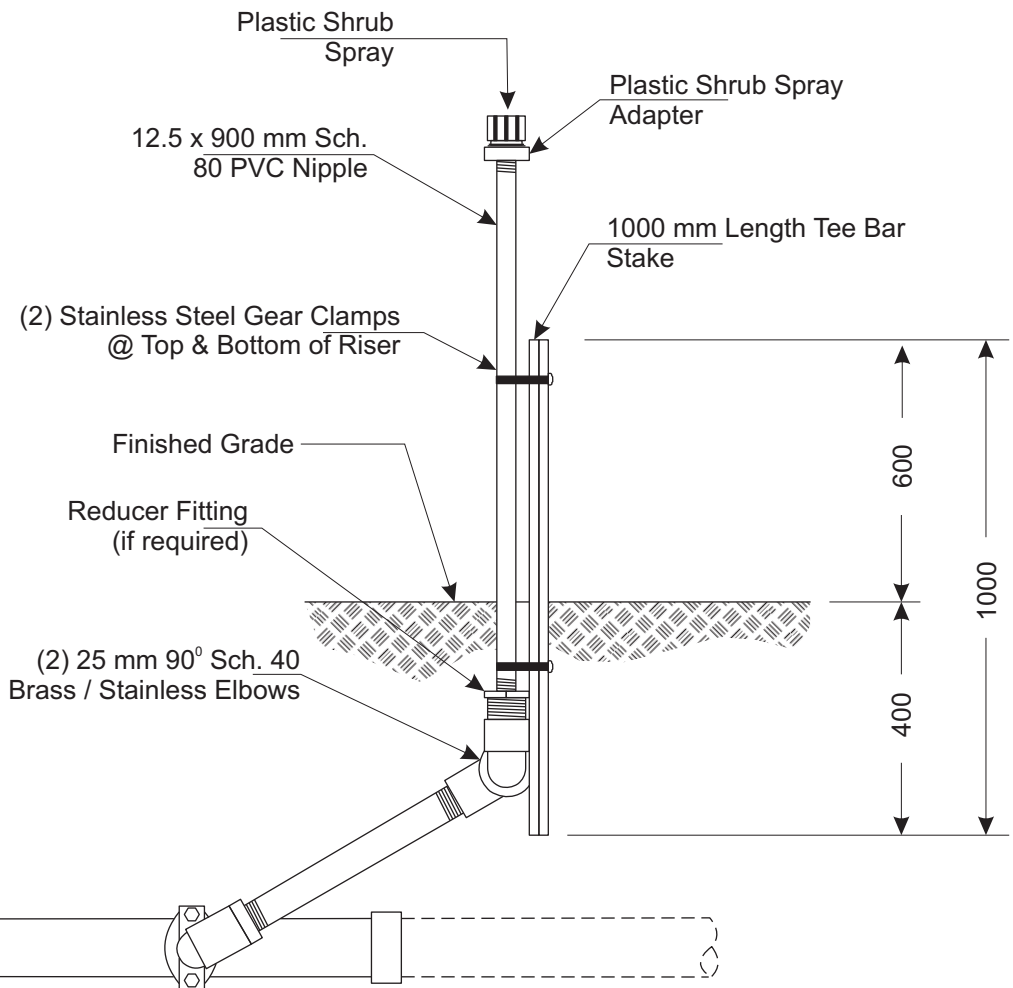
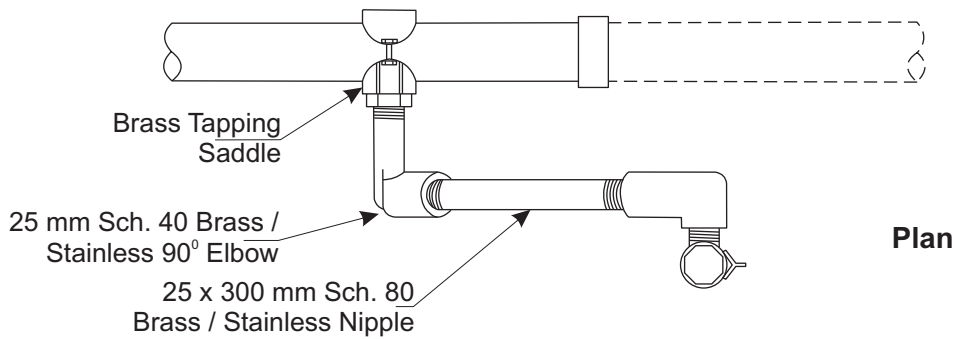

CITY OF CHESTERMERE
 Development & Infrastructure Services
 Parks Department



PR.0020.11
 January, 2015

SHEET TITLE:

Three Elbow Swing Joint
 - Plastic Riser & Shrub Head -

LANDSCAPE STANDARDS & SPECIFICATIONS

SHEET NO:	COCH-LS 84
DRAWN BY:	CB
DATE:	2014 Jan
SCALE:	N.T.S.

All dimensions are in millimetres unless otherwise specified.

Source: City of Calgary Standard Specifications for Landscape Construction, 2013.

LEGEND & REFERENCES:

1. Use galvanized fittings when installing turf valves or metal sprinkler heads.
2. Use Sch. 40 PVC fillings and Sch. 80 PVC nipples when installing plastic sprinkler heads.
3. Brass saddle shall not be closer than 150 mm from pipe end.

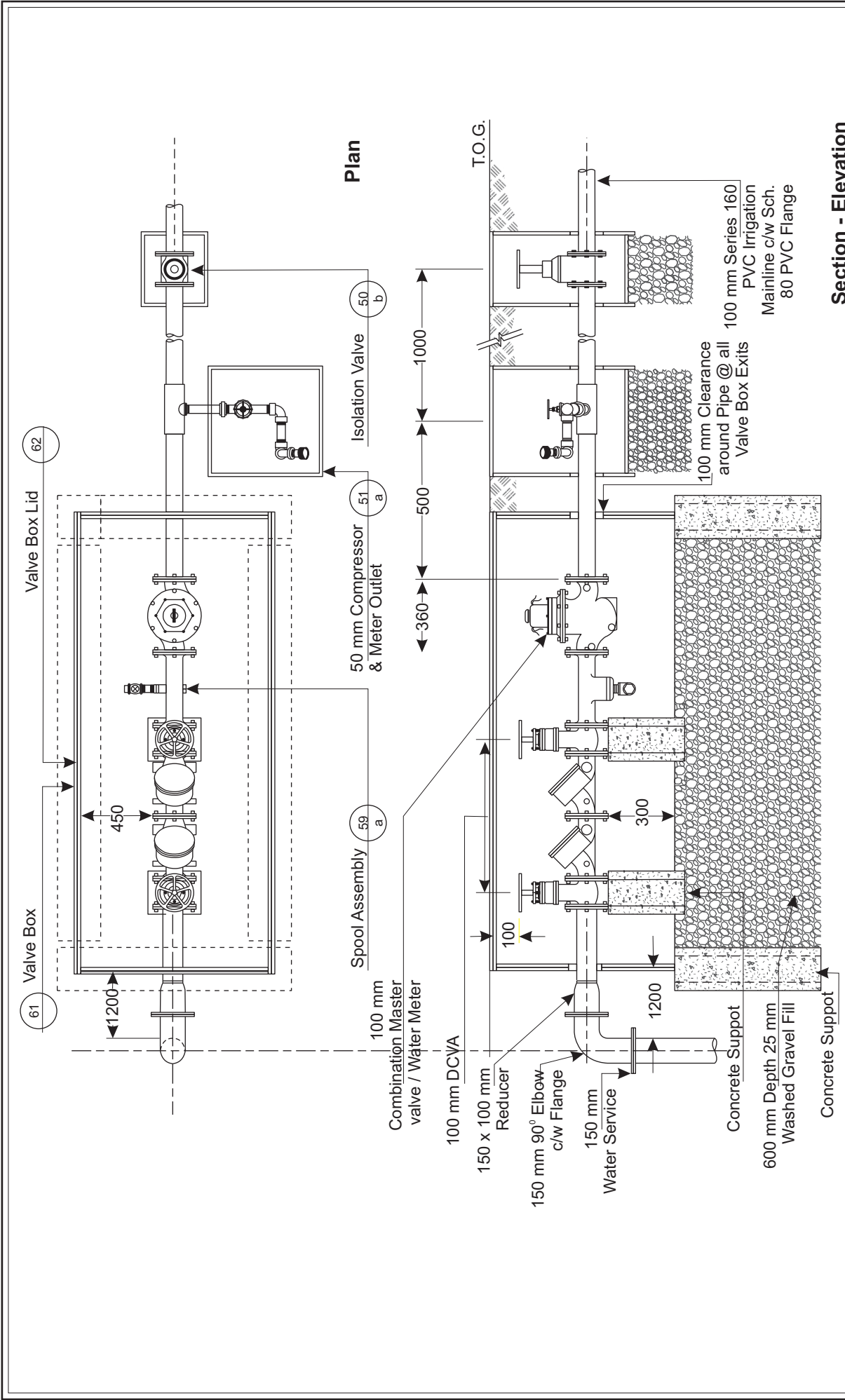

Section - Elevation

LEGEND & REFERENCES:

1. Double Check Valve Assembly shall conform to City of Calgary Waterworks Standard Specifications latest edition and be capable of being drained of water.
2. Eight (8) 1/4 gauge direct burial wires to run from water meter to controller box.
3. Strap and thrust block 90° elbow.
4. Paint all fabricated steel with 2 coats epoxy paint (blue colour).

SHEET NO:	COCH-LS 86	Units are in	millimetres
DRAWN BY:	CB	unless	otherwise
DATE:	2014/Jan	noted.	
SCALE:	N.T.S.		

Source: City of Calgary Standard Specifications for Landscape Construction, 2013.

SHEET TITLE:	Double Check Valve Assembly - 100 mm -
PROJECT TITLE:	LANDSCAPE STANDARDS & SPECIFICATIONS

CITY OF CHESTERMERE
Development & Infrastructure
Services
Parks Department

PR.0020.11
January, 2015



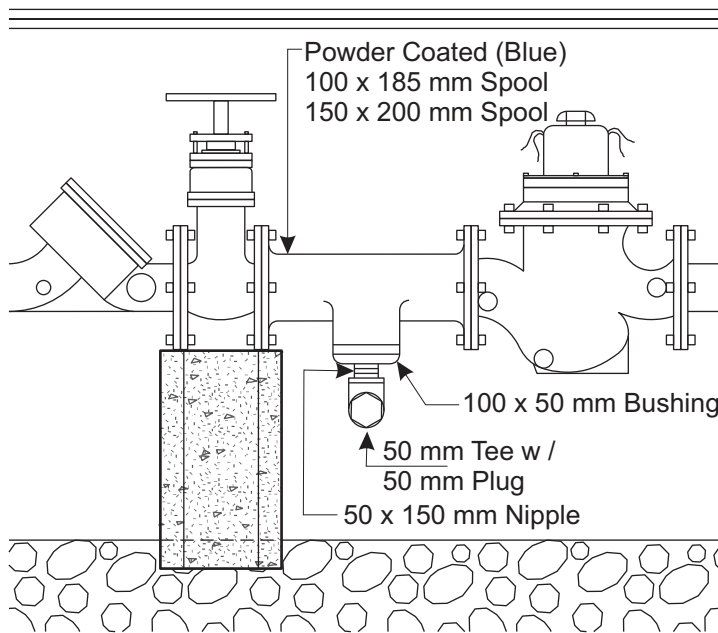

Elevation

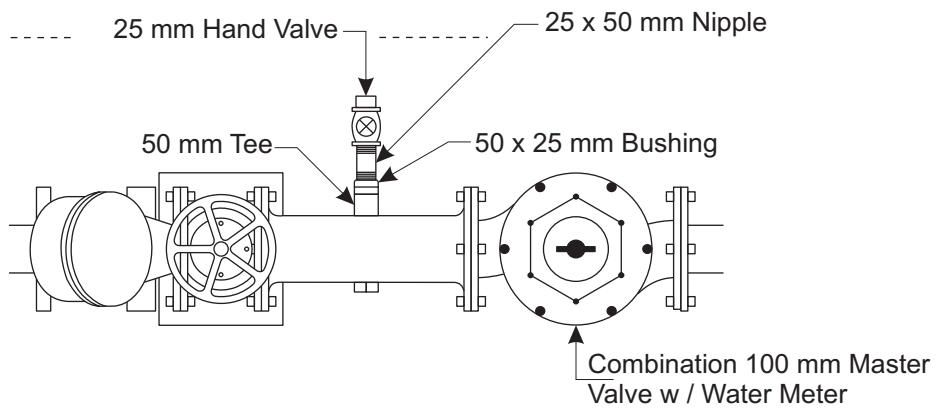

Plan

CITY OF CHESTERMERE
 Development & Infrastructure
 Services
 Parks Department



PR.0020.11
 January, 2015

SHEET TITLE:

Detail of Spool Assembly
 - 100 mm & 150 mm -

LANDSCAPE STANDARDS & SPECIFICATIONS

SHEET NO:	COCH-LS 87
DRAWN BY:	CB
DATE:	2014 Jan
SCALE:	N.T.S.

All dimensions are in millimetres unless otherwise specified.

Source: City of Calgary Standard Specifications for Landscape Construction, 2013.

LEGEND & REFERENCES:

1. All 25 mm Hand Valve fittings are to be Sch. 80 PVC Brass or Stainless Steel.
2. Length of 100 mm Spool from flange to flange is 185 mm.
3. Length of 150 mm Spool from flange to flange is 200 mm.

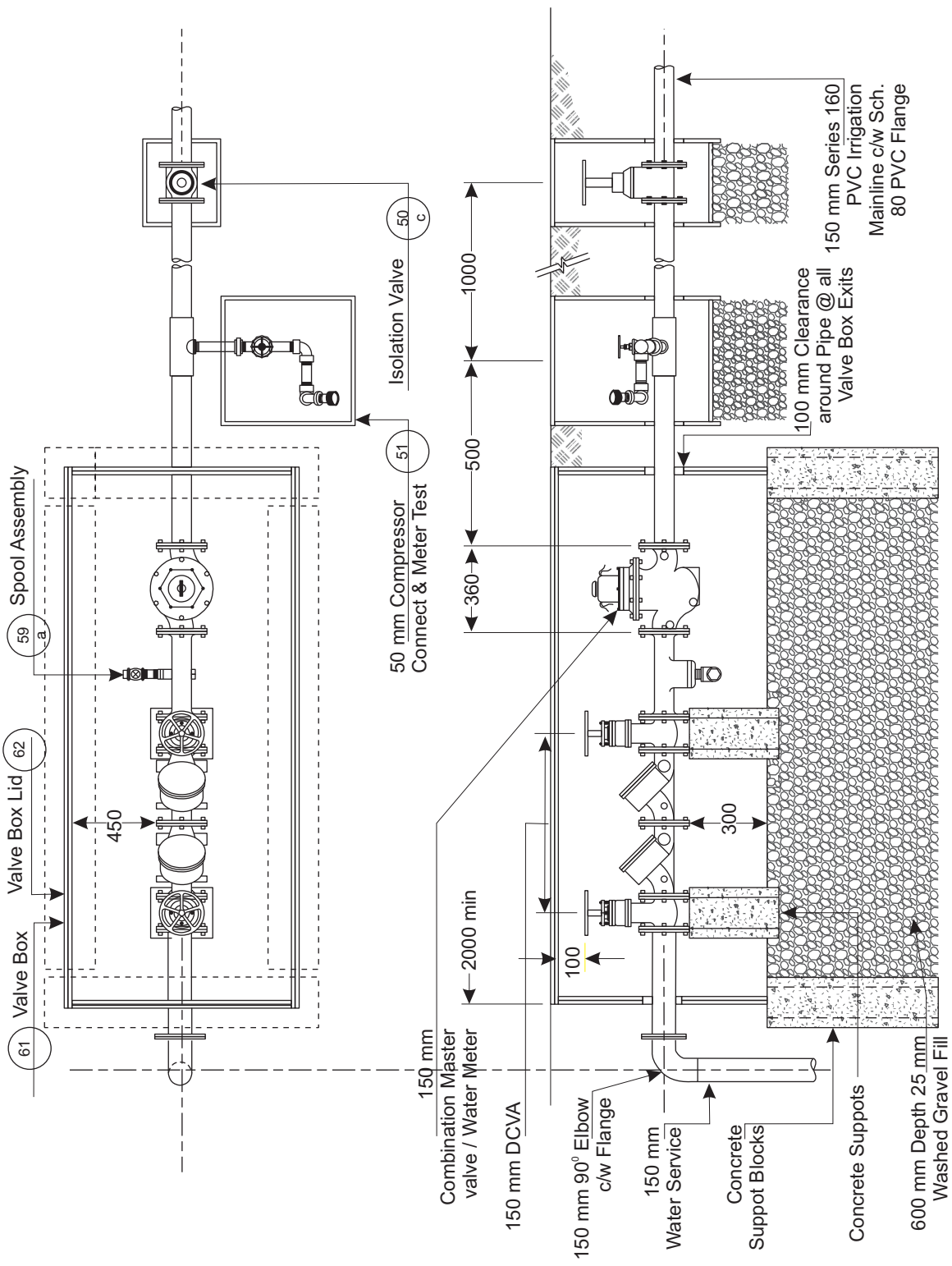

Plan

Section - Elevation

- LEGEND & REFERENCES:**
1. Double Check Valve Assembly shall conform to City of Calgary Waterworks Standard Specifications latest edition and be capable of being drained of water.
 2. Eight (8) 14 gauge direct burial wires to run from water meter to controller box.
 3. For box and lid specifications see detail sheets #99 and 101.
 4. Strap and thrust block 90° elbow.
 5. Paint all fabricated steel with 2 coats epoxy paint (blue colour).

SHEET NO:	COCH-LS 88	Units are in	millimetres
DRAWN BY:	CB	unless	
DATE:	2014/Jan	otherwise	
SCALE:	N.T.S.	noted.	

Source: City of Calgary Standard Specifications for Landscape Construction, 2013.

SHEET TITLE:
Double Check Valve Assembly
- 150 mm -

PROJECT TITLE:
LANDSCAPE STANDARDS & SPECIFICATIONS

CITY OF CHESTERMERE
Development & Infrastructure
Services
Parks Department

PR.0020.11
January, 2015



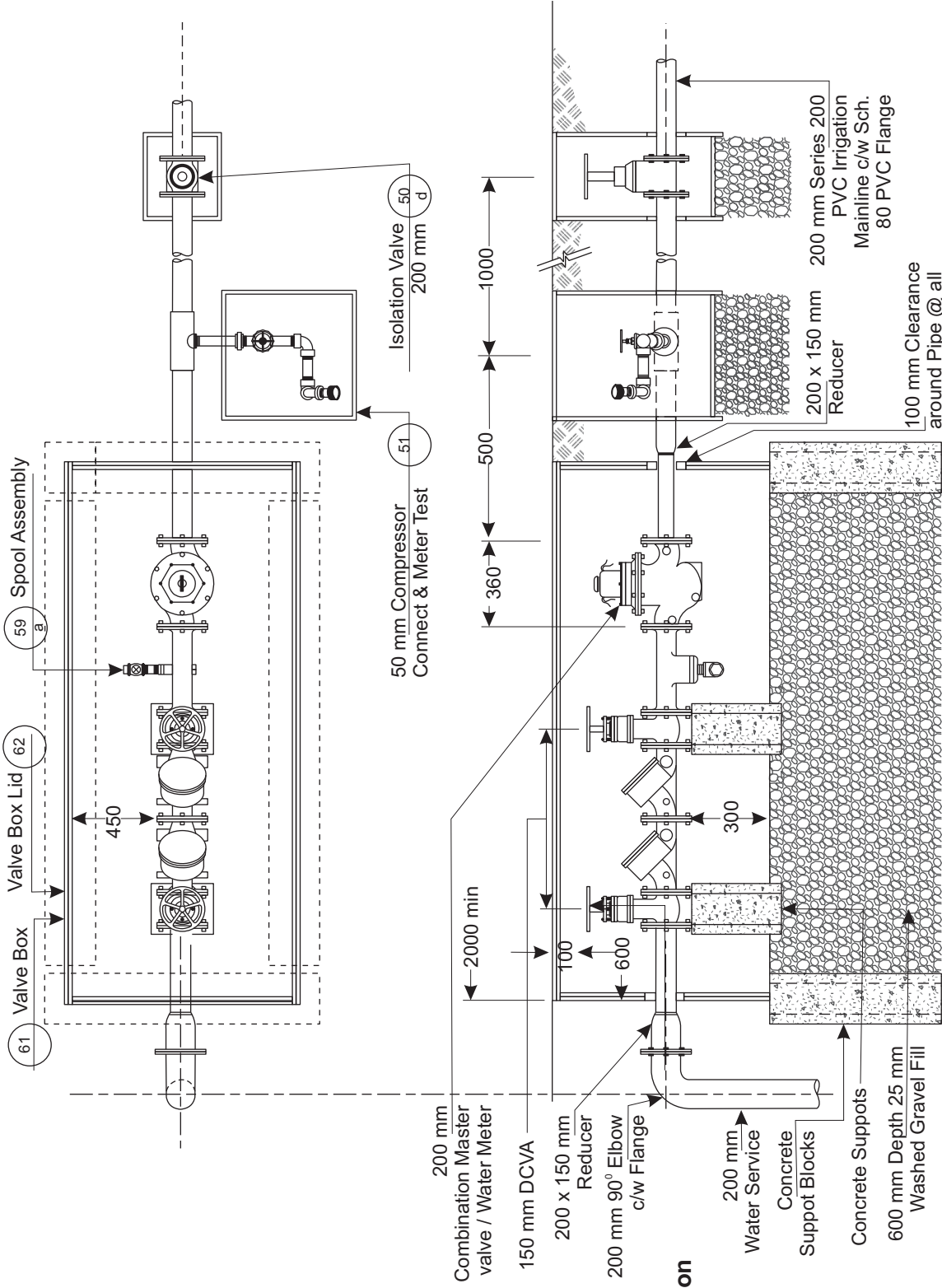

Plan

Section - Elevation

LEGEND & REFERENCES:

1. Double Check Valve Assembly shall conform to City of Calgary Waterworks Standard Specifications latest edition and be capable of being drained of water.
2. Eight (8) 14 gauge direct burial wires to run from water meter to controller box.
3. For box and lid specifications see detail sheets #99 and 101.
4. Strap and thrust block 90° elbow.
5. Paint all fabricated steel with 2 coats epoxy paint (blue colour).

SHEET NO:	COCH-LS 89	Units are in	millimetres
DRAWN BY:	CB	unless	otherwise
DATE:	2014/Jan	noted.	
SCALE:	N.T.S.		

Source: City of Calgary Standard Specifications for Landscape Construction, 2013.

SHEET TITLE:
Double Check Valve Assembly
- 200 mm -

PROJECT TITLE:
LANDSCAPE STANDARDS & SPECIFICATIONS

CITY OF CHESTERMERE
Development & Infrastructure Services
Parks Department

PR.0020.11
January, 2015



Weatherproof Metal Controller Cabinet as manufactured by Ace Mfg. Co. Ltd. Nema 3 or Equiv. Eurobec 1300 MC Cema 3R (double door)

Lockable Doors-Handles with Internal Roller Mechanism

Electrical Surge Protector by Northern Technologies Model TCS-HW

Quad. Receptical c/w GFCI Protection

Breaker Box c/w (2) 15 amp Single-pole GFI Breakers

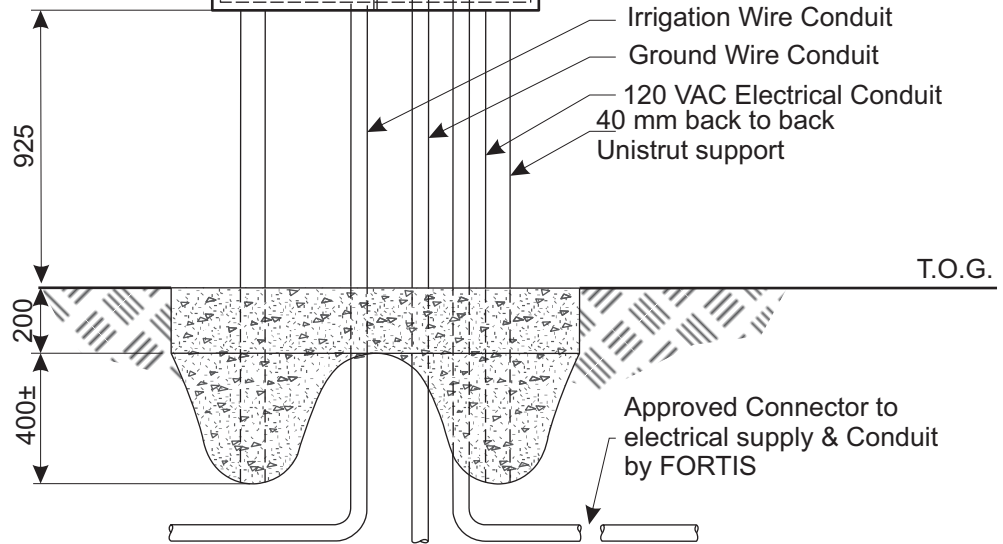

Elevation

Unistrut supports bolted to outside back of Cabinet

900 x 900 mm 20 Mpa Concrete Base

Provide ample concrete surface for personal operating / maintaining controller

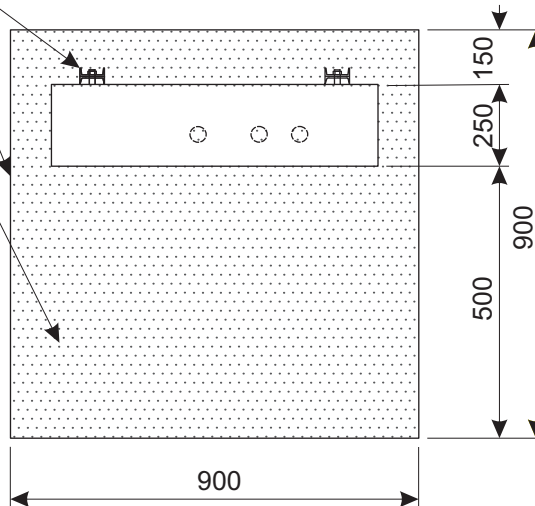

Plan

CITY OF CHESTERMERE

Development & Infrastructure Services
Parks Department



PR.0020.11
January, 2015

SHEET TITLE:

Irrigation Controller Cabinet

LANDSCAPE STANDARDS & SPECIFICATIONS

SHEET NO: COCH-LS 90

DRAWN BY: CB

DATE: 2013Dec

SCALE: N.T.S.

All dimensions are in millimetres unless otherwise specified.

Source: City of Calgary Standard Specifications for Landscape Construction, 2013.

LEGEND & REFERENCES:

1. Controller cabinet shall have electrical surge protection and grounded to 5 ohms or less.
2. Cabinet shall be:
 - < 15 zones: 750 x 750 x 250 mm
 - >= 15 zones: 900 x 900 x 300 mm

Plan

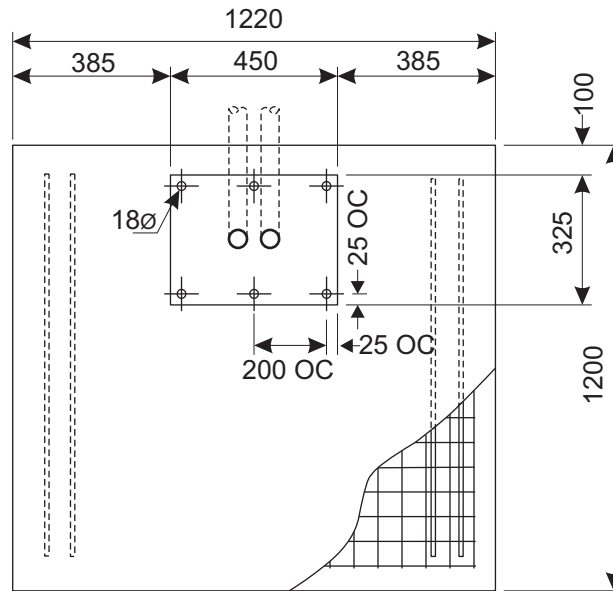

Section

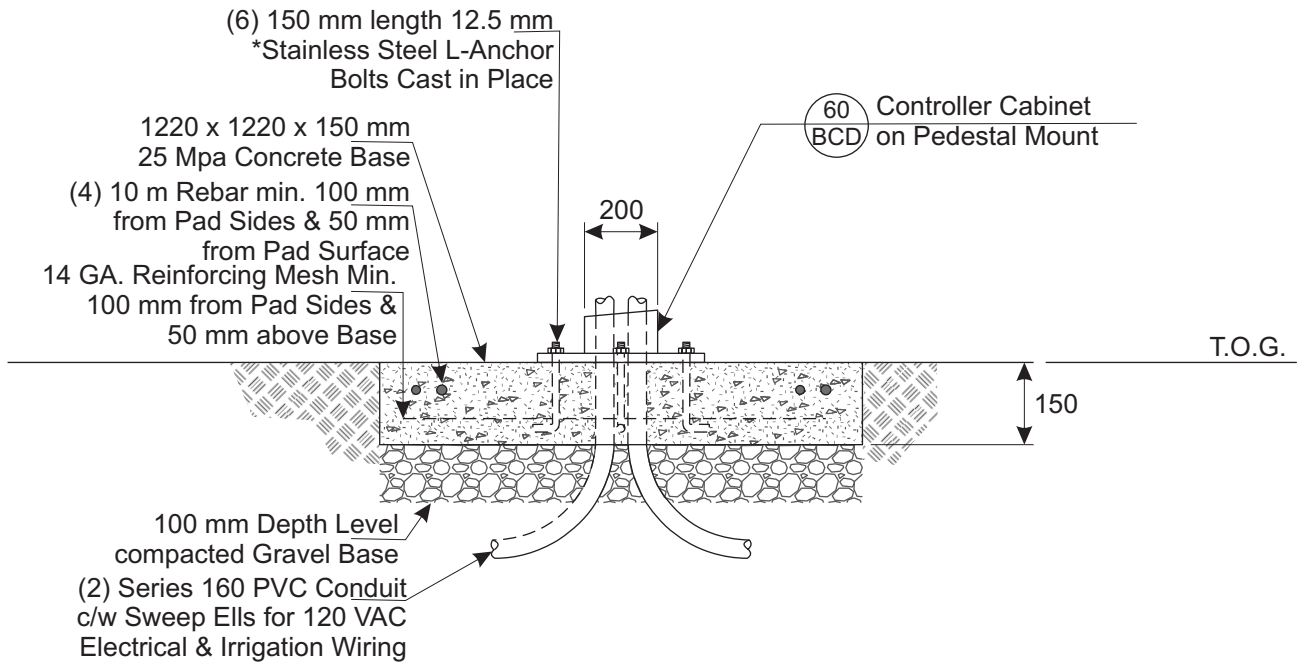

CITY OF CHESTERMERE
Development & Infrastructure
Services
Parks Department



PR.0020.11
January, 2015

SHEET TITLE:

Irrigation Controller Cabinet
- Concrete Pad -

LANDSCAPE STANDARDS & SPECIFICATIONS

SHEET NO: COCH-LS 91

DRAWN BY: CB

DATE: 2014 Jan

SCALE: N.T.S.

All dimensions are in millimetres
unless otherwise specified.

Source: City of Calgary Standard
Specifications for Landscape
Construction, 2013.

LEGEND & REFERENCES:

1. Contractor shall confirm all bolt templates w/ control box manufacturer prior to construction of concrete pad.
2. Conduit shall be sized so as wires do not exceed 40% * of pipe diameter.
3. Verify anchor bolt placements w/ bolt template supplied by pedestal manufacturer.

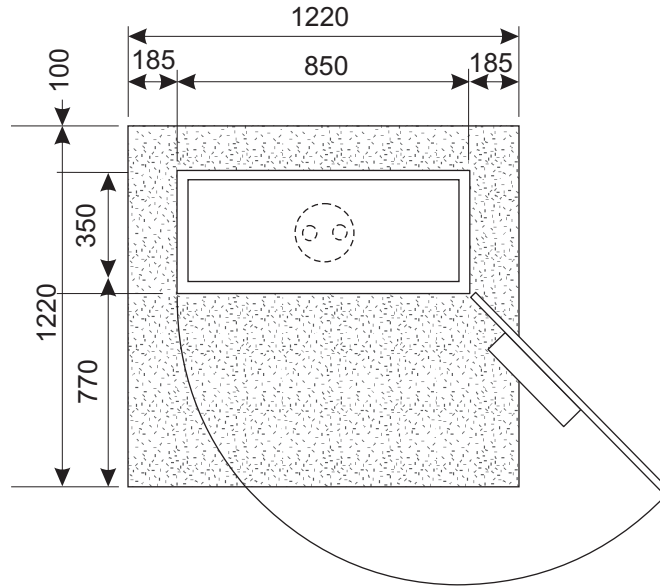

Plan

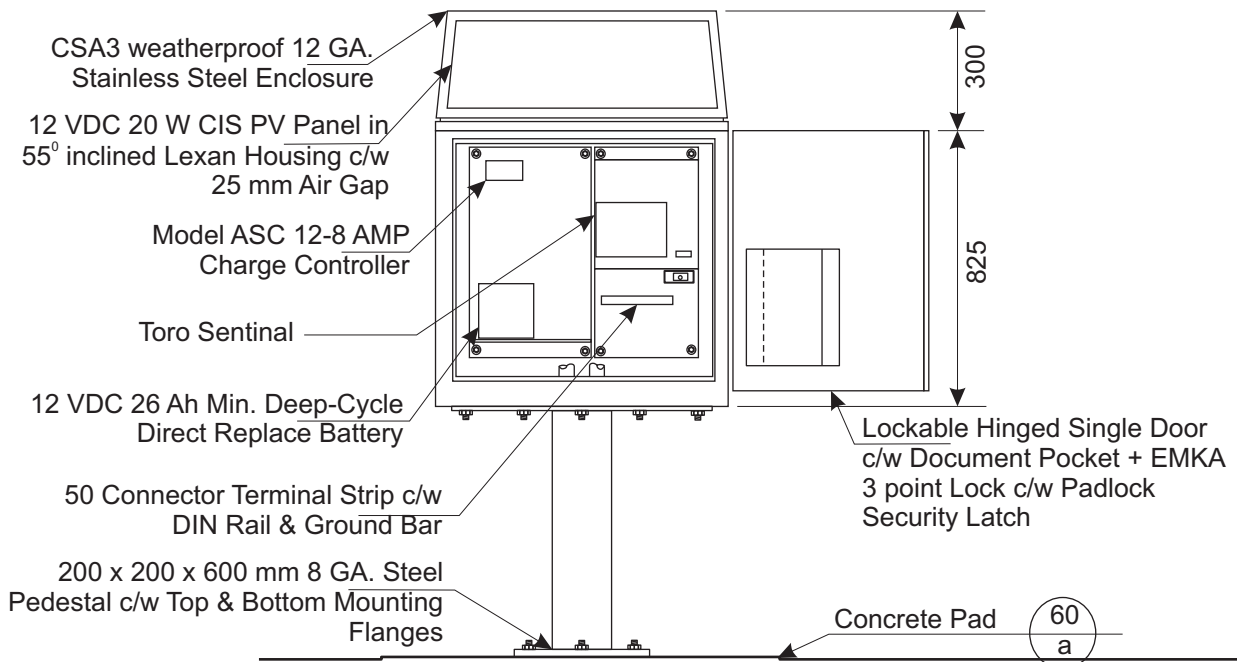

Elevation

CITY OF CHESTERMERE
 Development & Infrastructure
 Services
 Parks Department



PR.0020.11
 January, 2015

SHEET TITLE:
 Control Cabinet & Pedestal
 - Toro Sentinal -

LANDSCAPE STANDARDS & SPECIFICATIONS

SHEET NO:	COCH-LS 92
DRAWN BY:	CB
DATE:	2014 Jan
SCALE:	N.T.S.

All dimensions are in millimetres unless otherwise specified.

Source: *City of Calgary Standard Specifications for Landscape Construction, 2013.*

LEGEND & REFERENCES:

- Contractor shall confirm all pedestal bolt templates w/ control box manufacturer prior to installation.
- Cabinet shall be powder coated w/ PFT-500-S8 almond finish or equivalent.
- All components shall be CSA approved and subject of applicable municipal, provincial, and national municipal codes & bylaws.
- (2) quadraplex outlets in duplex boxes c/w cover.

Top View

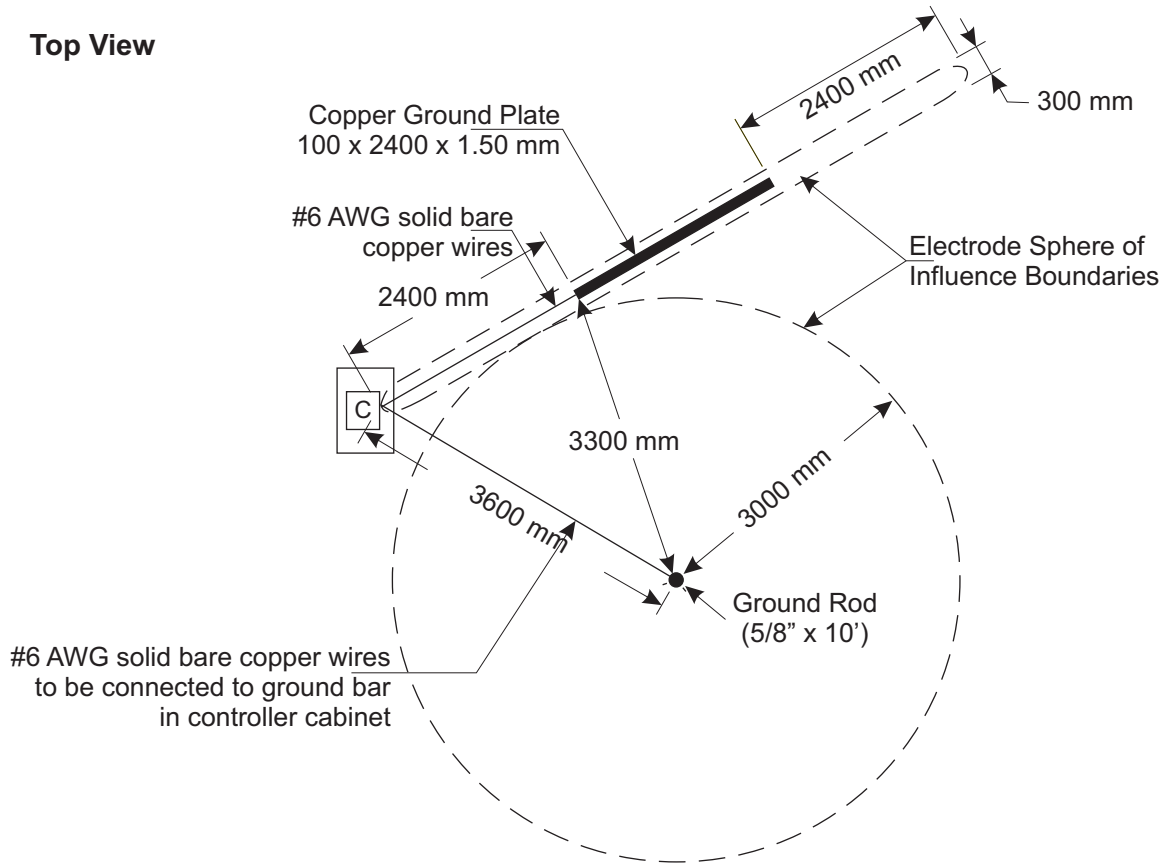

Side View

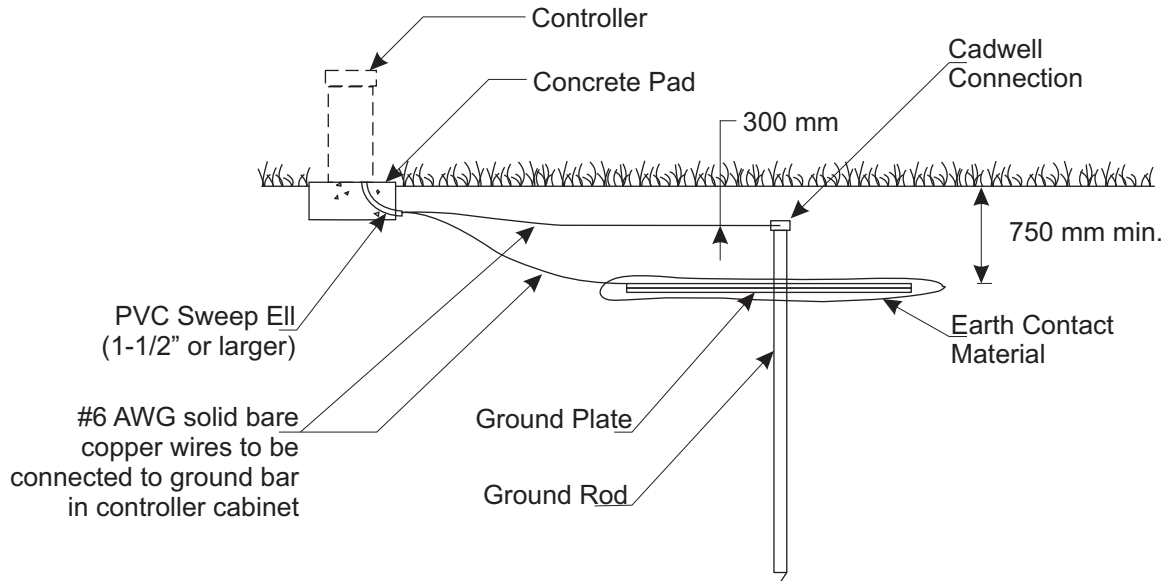

CITY OF CHESTERMERE

Development & Infrastructure
Services
Parks Department



PR.0020.11
January, 2015

SHEET TITLE:

Figure 2-Up to 64 Stations
- Non-Rocky Soils -

**LANDSCAPE STANDARDS &
SPECIFICATIONS**

SHEET NO: COCH-LS 93

DRAWN BY: As per ASIC

DATE: 2014 Jan

SCALE: N.T.S.

All dimensions are in millimetres
unless otherwise specified.

Source: City of Calgary Standard
Specifications for Landscape
Construction, 2013.

LEGEND & REFERENCES:

Do not install any other wires or
cable within the sphere of
influence.

Top View

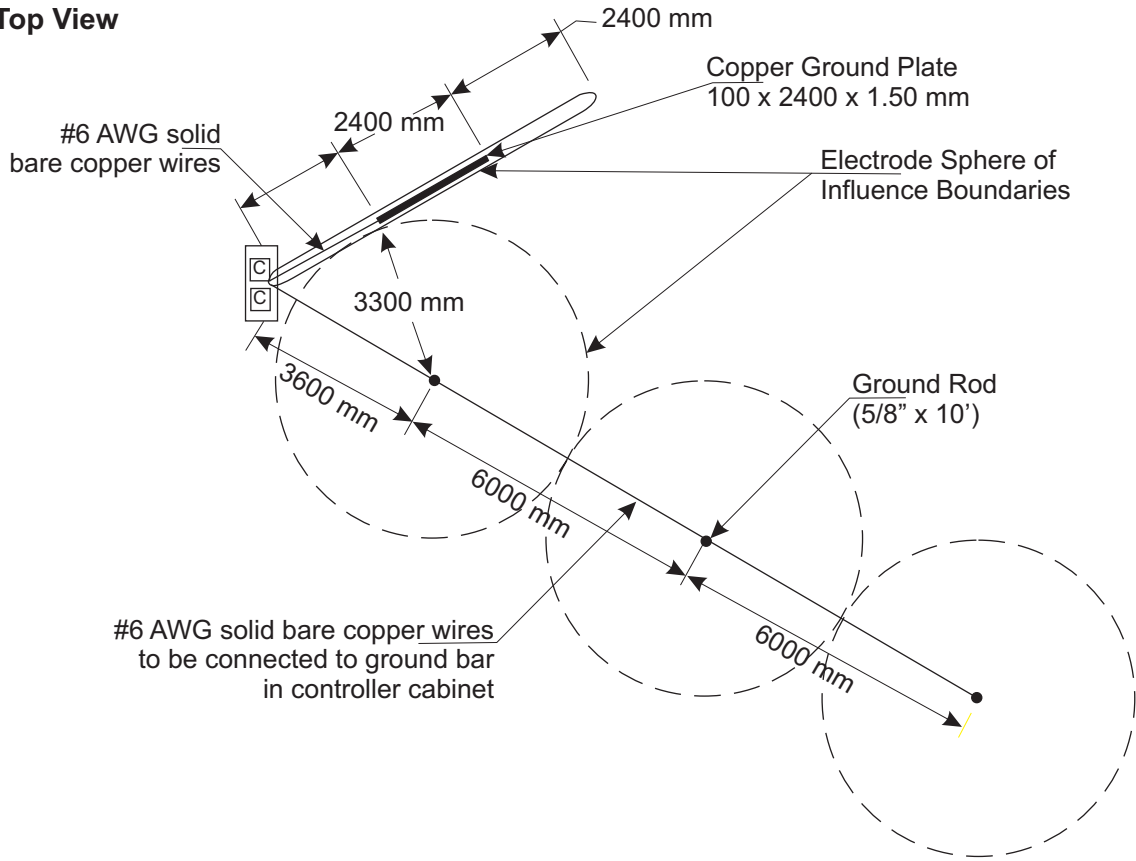

Side View

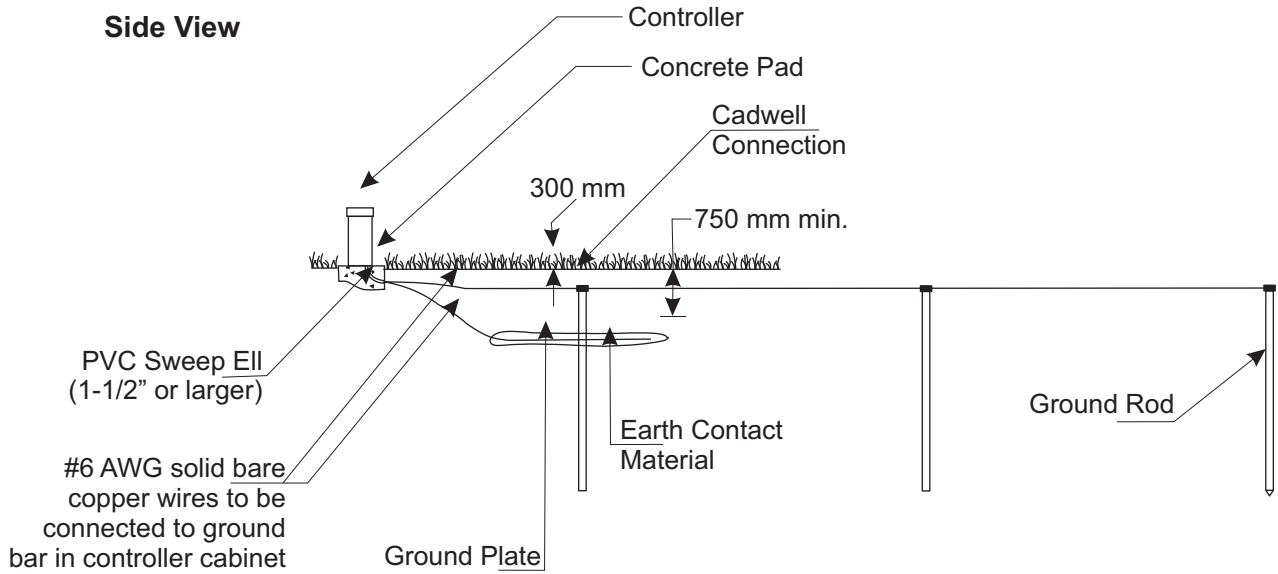

CITY OF CHESTERMERE

Development & Infrastructure
Services
Parks Department



PR.0020.11
January, 2015

SHEET TITLE:

Figure 4-Up to 96 Stations
- Non-Rocky Soils -

**LANDSCAPE STANDARDS &
SPECIFICATIONS**

SHEET NO: COCH-LS 94

DRAWN BY: As per ASIC

DATE: 2014 Jan

SCALE: N.T.S.

All dimensions are in millimetres
unless otherwise specified.

Source: City of Calgary Standard
Specifications for Landscape
Construction, 2013.

LEGEND & REFERENCES:

Do not install any other wires or
cable within the sphere of
influence.

Top View

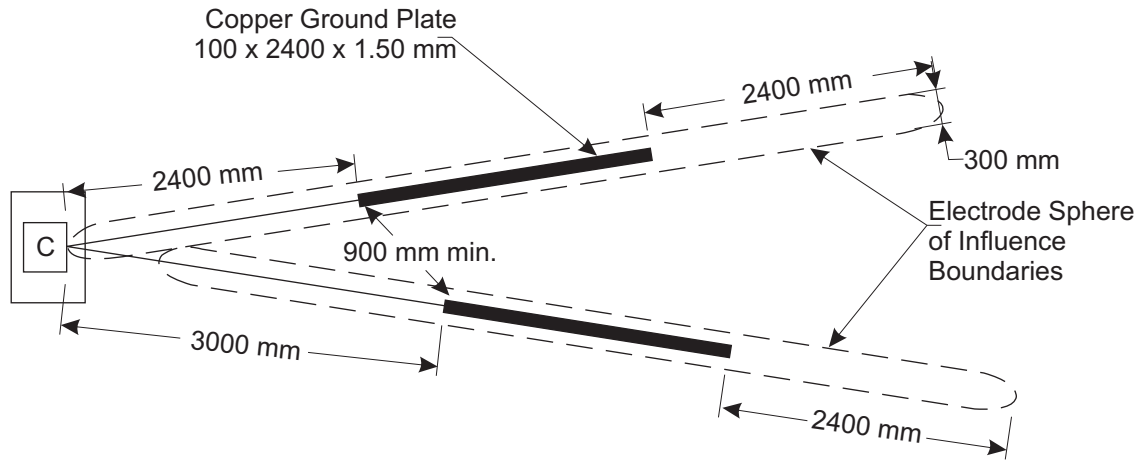

Side View

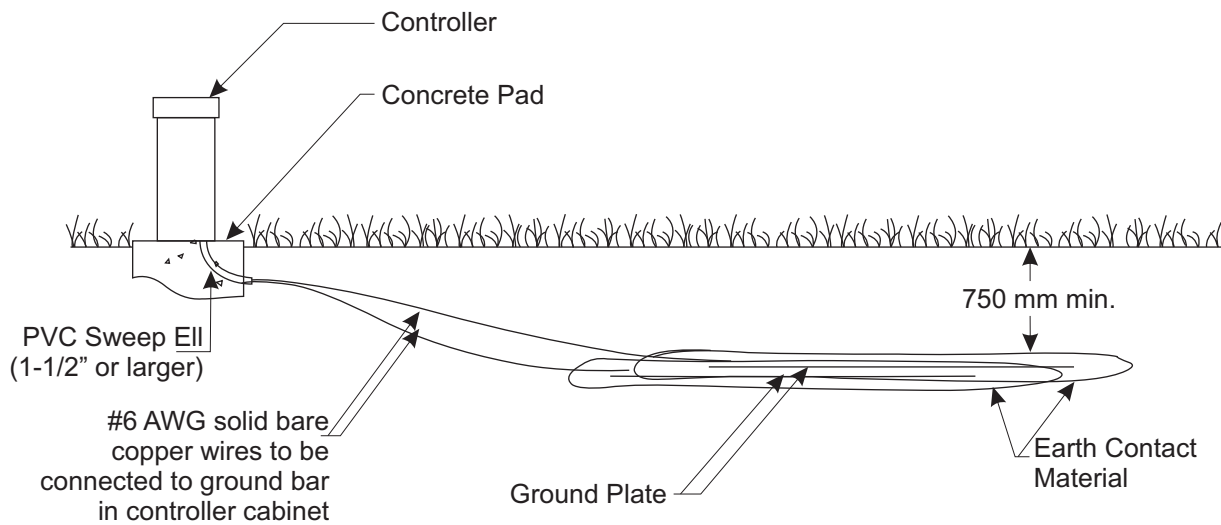

CITY OF CHESTERMERE
 Development & Infrastructure
 Services
 Parks Department



PR.0020.11
 January, 2015

SHEET TITLE:

Figure 3-Up to 64 Stations
 - Rocky Soils -

**LANDSCAPE STANDARDS &
 SPECIFICATIONS**

SHEET NO: COCH-LS 95

DRAWN BY: As per ASIC

DATE: 2013Dec

SCALE: N.T.S.

All dimensions are in millimetres
 unless otherwise specified.

Source: City of Calgary Standard
 Specifications for Landscape
 Construction, 2013.

LEGEND & REFERENCES:

Do not install any other wires or
 cable within the sphere of
 influence.

Top View

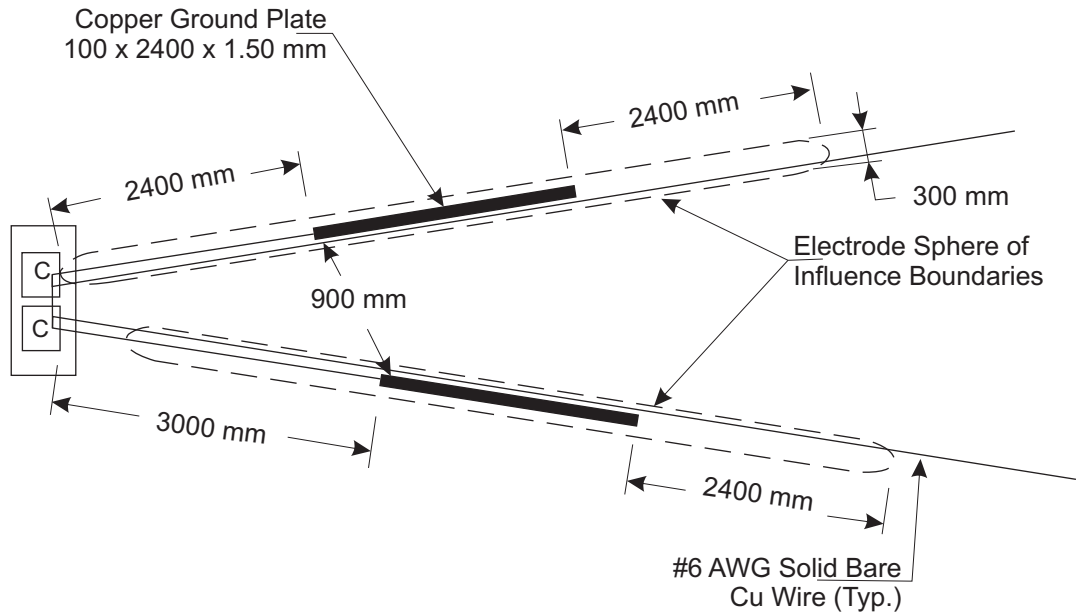

Side View

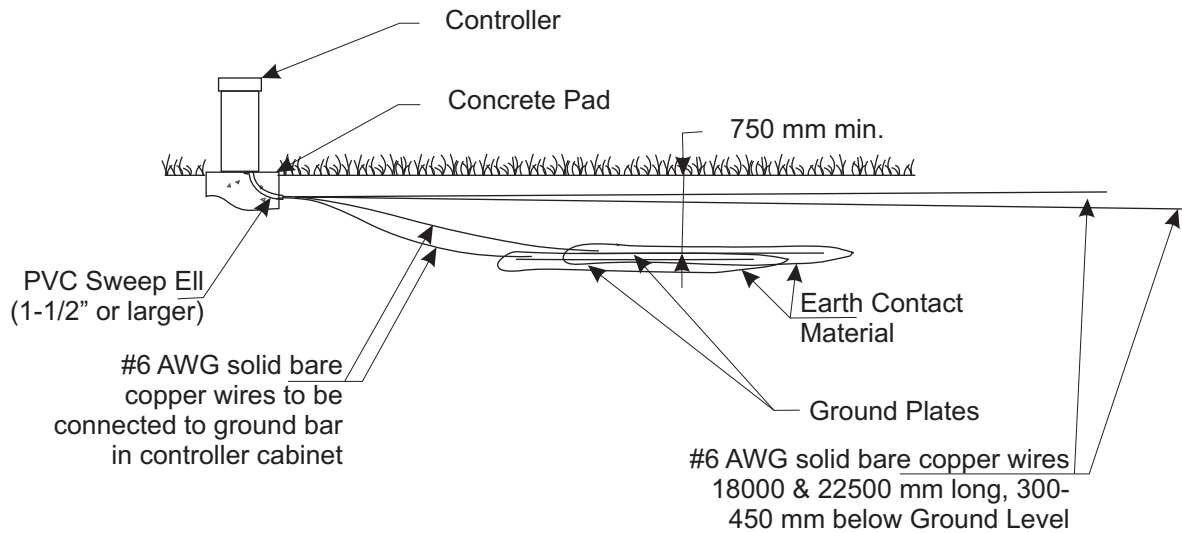

CITY OF CHESTERMERE

Development & Infrastructure
Services
Parks Department



PR.0020.11
January, 2015

SHEET TITLE:

Up to 96 Stations
- Rocky Soils -

LANDSCAPE STANDARDS & SPECIFICATIONS

SHEET NO: COCH-LS 96

DRAWN BY: As per ASIC

DATE: 2014 Jan

SCALE: N.T.S.

All dimensions are in millimetres unless otherwise specified.

Source: City of Calgary Standard Specifications for Landscape Construction, 2013.

LEGEND & REFERENCES:

1. Do not install any other wires or cable within the sphere of influence.
2. For sites with more stations contact The City of Chestermere Landscape Technician.

Top View

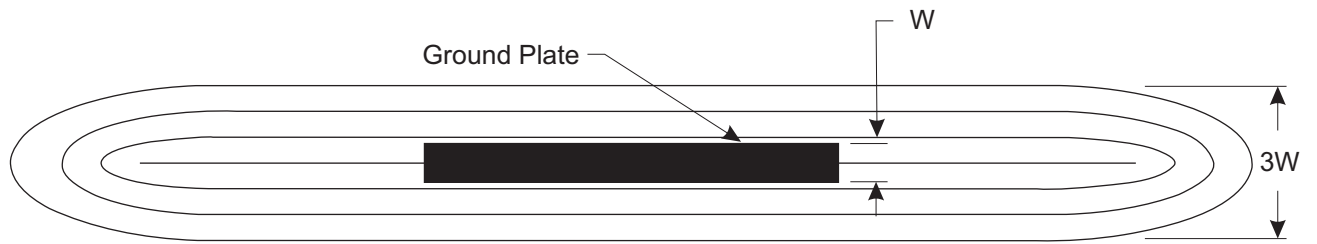

Side View

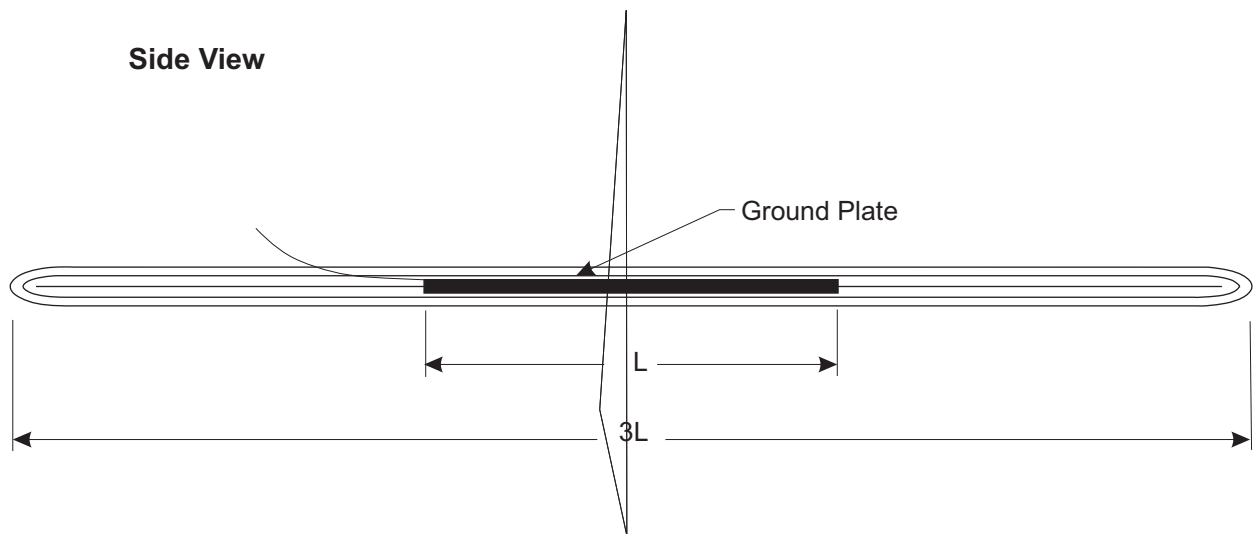

CITY OF CHESTERMERE
 Development & Infrastructure
 Services
 Parks Department



PR.0020.11
 January, 2015

SHEET TITLE:

Sphere of Influence
 - Ground Plate -

**LANDSCAPE STANDARDS &
 SPECIFICATIONS**

SHEET NO: COCH-LS 97

DRAWN BY: CB

DATE: 2013Dec

SCALE: N.T.S.

All dimensions are in metric unless
 otherwise specified.

Source: *City of Calgary Standard
 Specifications for Landscape
 Construction, 2013.*

LEGEND & REFERENCES:

Top View

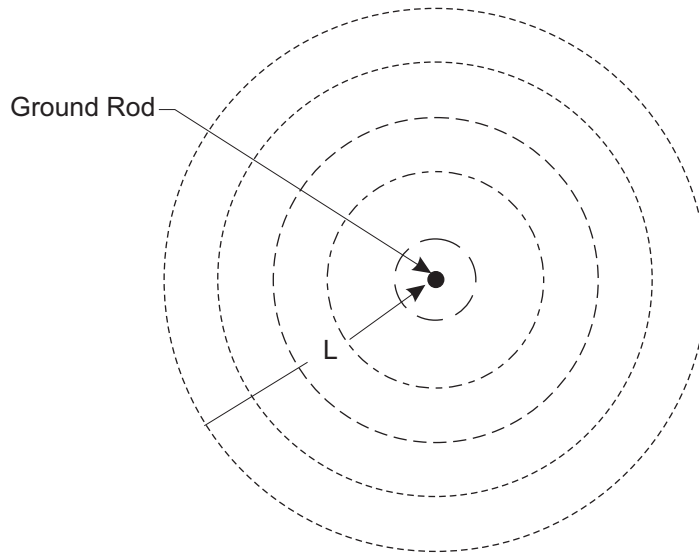

Side View

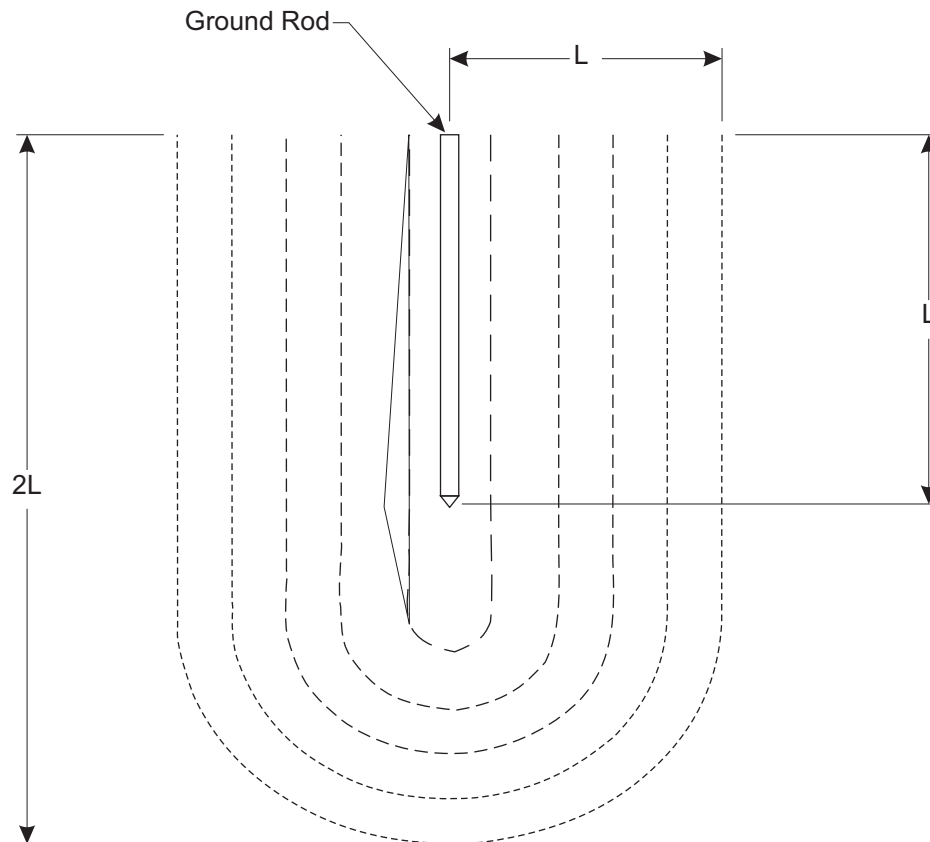

CITY OF CHESTERMERE

Development & Infrastructure
Services
Parks Department



PR.0020.11
January, 2015

SHEET TITLE:

Sphere of Influence
- Ground Rod -

**LANDSCAPE STANDARDS &
SPECIFICATIONS**

SHEET NO: COCH-LS 98

DRAWN BY: CB

DATE: 2013Dec

SCALE: N.T.S.

All dimensions are in metric unless
otherwise specified.

Source: City of Calgary Standard
Specifications for Landscape
Construction, 2013.

LEGEND & REFERENCES:

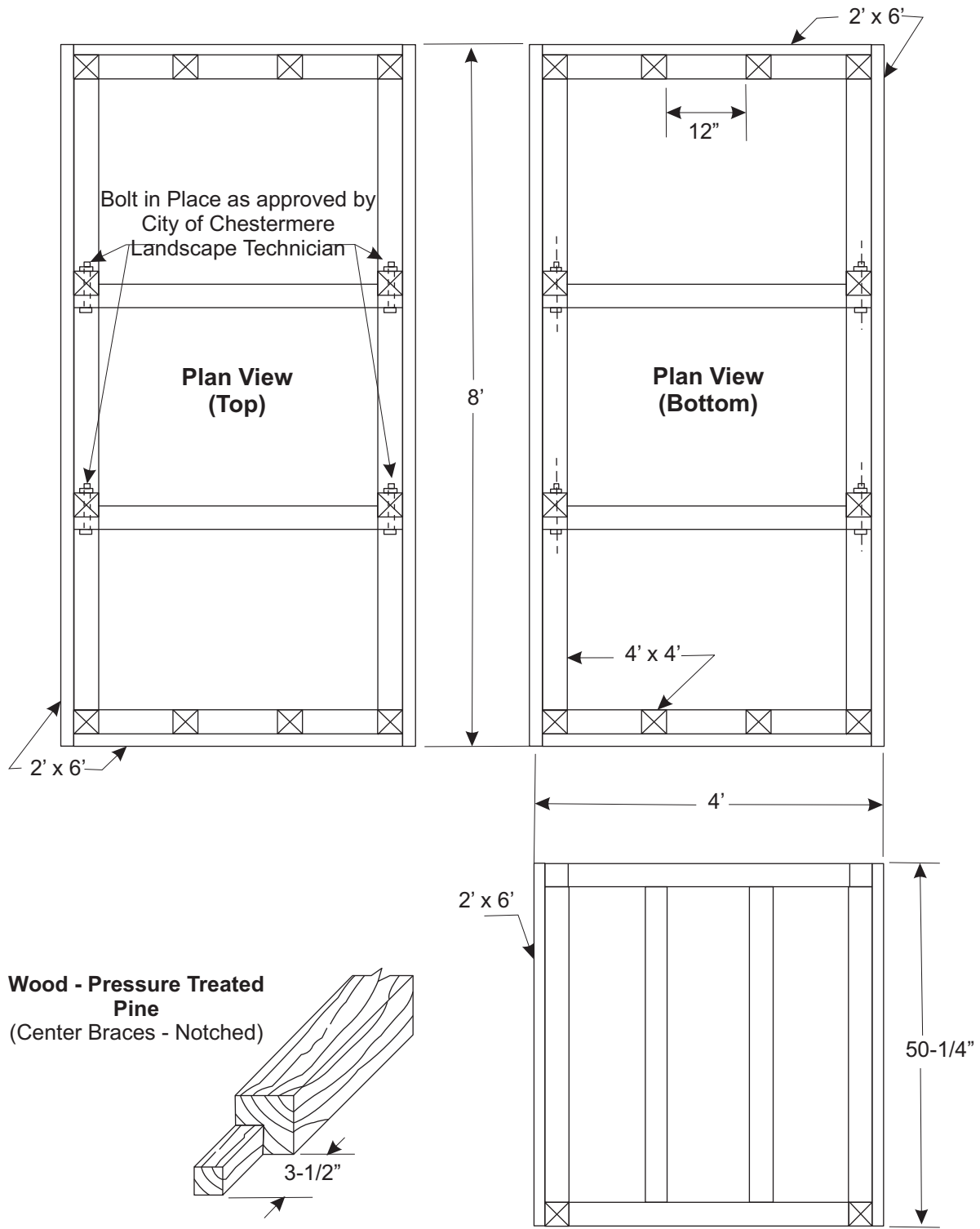

CITY OF CHESTERMERE
Development & Infrastructure Services
Parks Department



PR.0020.11
January, 2015

SHEET TITLE:
Valve Box Details for Double Check Valve Assembly
- 100 mm -

LANDSCAPE STANDARDS & SPECIFICATIONS

SHEET NO:	COCH-LS 99
DRAWN BY:	CB
DATE:	2014 Jan
SCALE:	N.T.S.

All dimensions are in imperial unless otherwise specified.

Source: City of Calgary Standard Specifications for Landscape Construction, 2013.

LEGEND & REFERENCES:

Cutting List

Side Boards	18 pcs.	2x6x8'
End Boards	18 pcs.	2x6x45"
Bottom Plates	2 pcs.	4x4x93"
	2 pcs.	4x4x38"
Vertical Bracing	12 pcs.	4x4x43-1/8"
Top Plates	2 pcs.	4x4x93" Mitered
	2 pcs.	4x4x45" Mitered
Center Braces	4 pcs	4x4x45" Notched

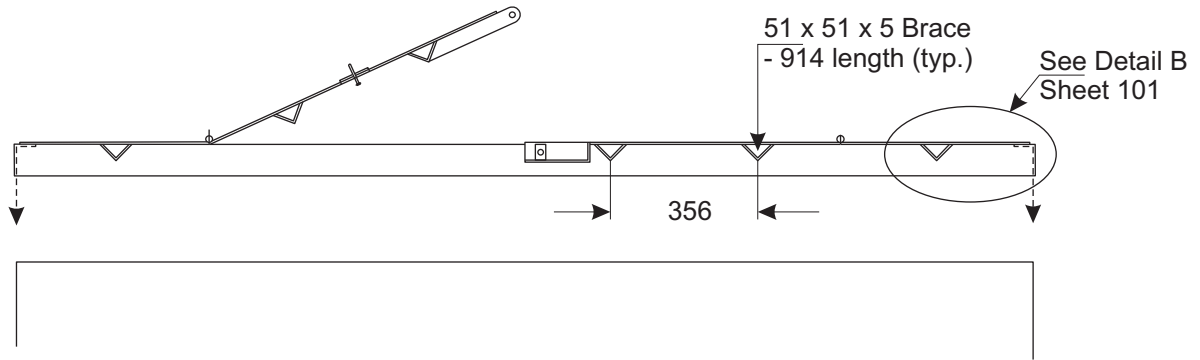

Section A-A

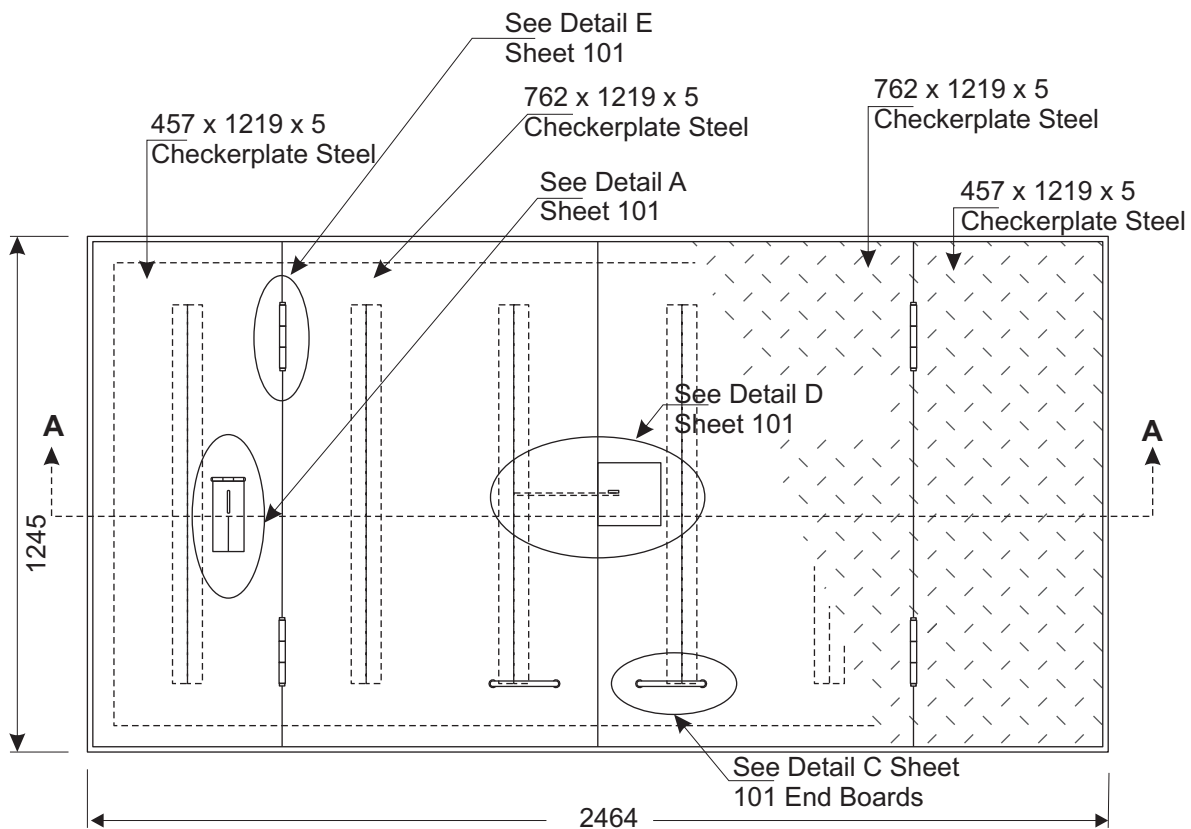

Plan View

CITY OF CHESTERMERE
 Development & Infrastructure
 Services
 Parks Department



PR.0020.11
 January, 2015

SHEET TITLE:
 Double Check Valve Box and
 Meter Viewing with Lid
 - 100 mm -

**LANDSCAPE STANDARDS &
 SPECIFICATIONS**

SHEET NO:	COCH-LS 100
DRAWN BY:	CB
DATE:	2014 Jan
SCALE:	N.T.S.

All dimensions are in millimetres unless otherwise specified.

Source: City of Calgary Standard Specifications for Landscape Construction, 2013.

LEGEND & REFERENCES:

1. Finish to be red oxide primer.
2. Meter viewing port location is schematic and is anticipated to be above the meter.
3. For Box Details see Sheet 99.

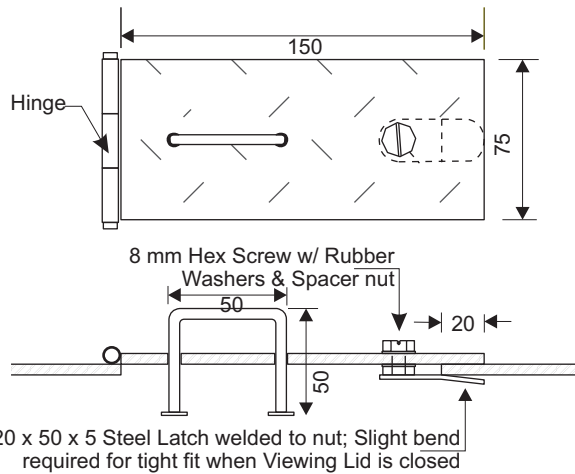

Detail A - Meter Viewing Lid

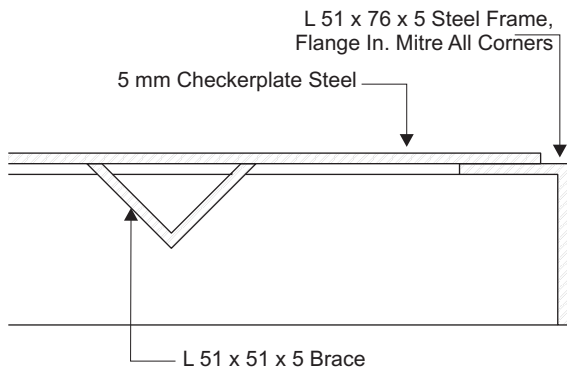

Detail B - Frame

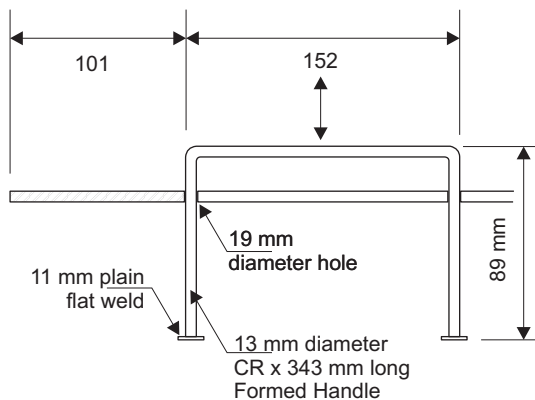

Detail C - Door Handle

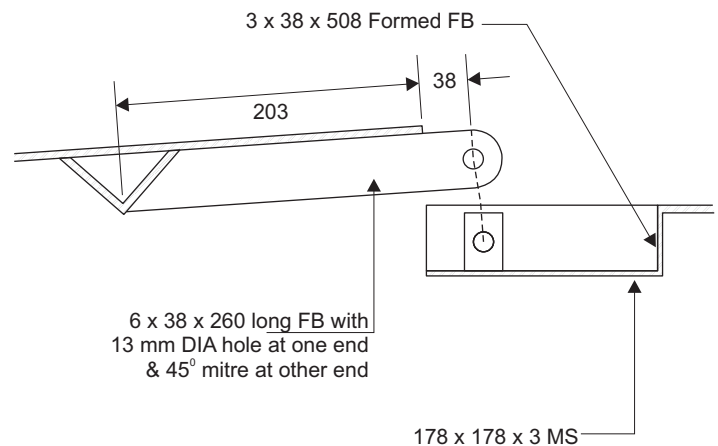
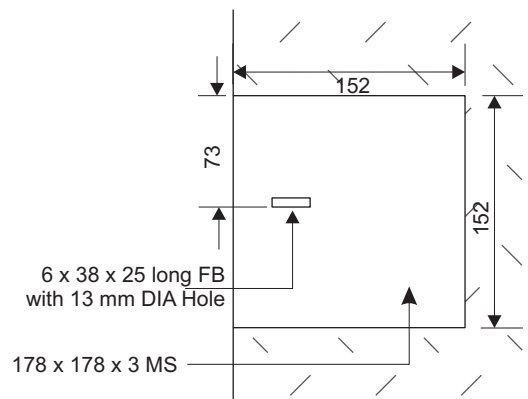

Detail D - Door Latch

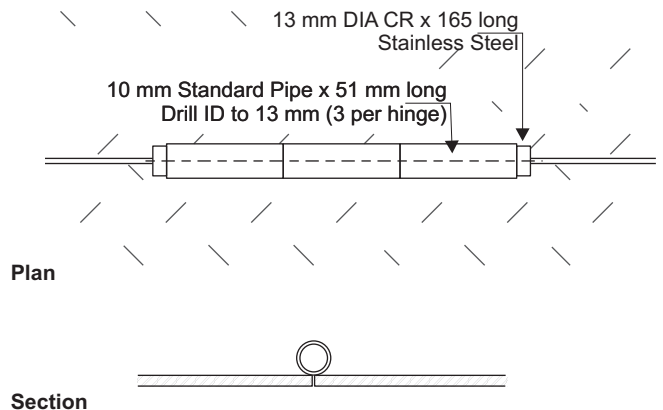

Detail E - Door Hinge

CITY OF CHESTERMERE
Development & Infrastructure Services
Parks Department



PR.0020.11
January, 2015

SHEET TITLE:
Double Check Valve Box Lid with
Meter Viewing with Lid
- 100 mm -

LANDSCAPE STANDARDS & SPECIFICATIONS

SHEET NO: COCH-LS 101
DRAWN BY: CB
DATE: 2014 Jan
SCALE: N.T.S.

All dimensions are in millimetres unless otherwise specified.

Source: City of Calgary Standard Specifications for Landscape Construction, 2013.

LEGEND & REFERENCES:

1. Meter viewing lid to be located directly above anticipated location for meter.

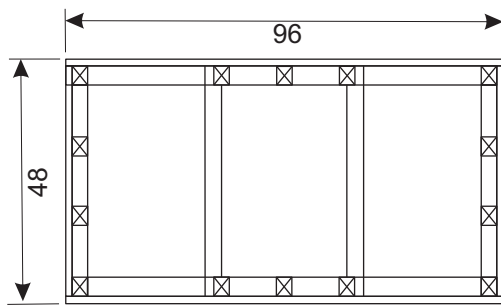

Plan View

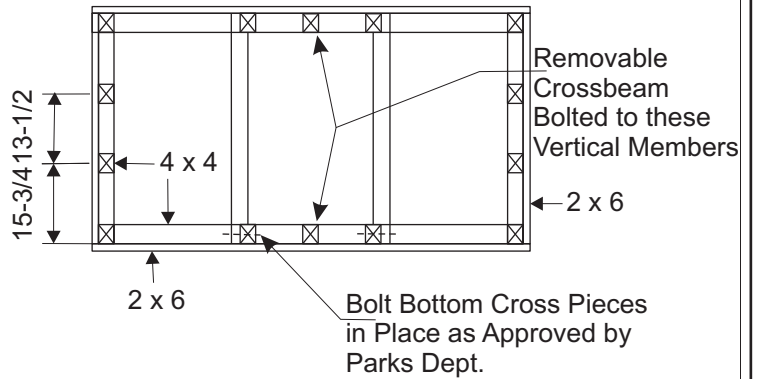

Plan View Bottom

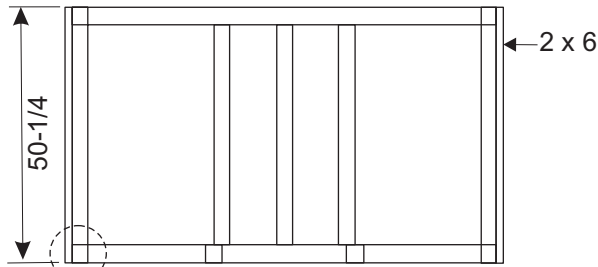

Side View

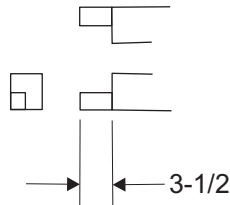

Detail AA

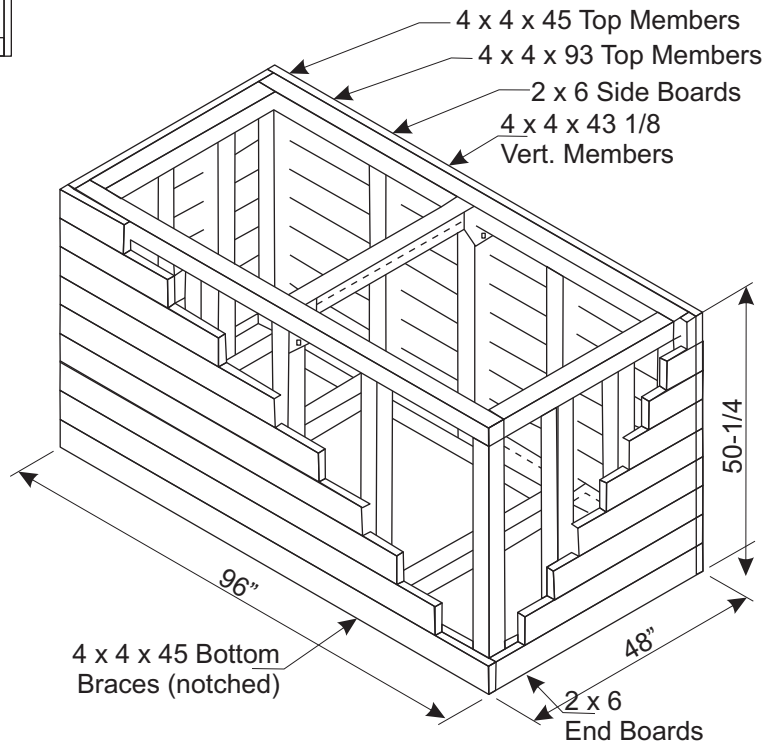

Three Dimensional (3D) View

CITY OF CHESTERMERE
Development & Infrastructure
Services
Parks Department



PR.0020.11
January, 2015

SHEET TITLE:
Valve Box - Double Check Valve
Assembly
- 100 mm -

**LANDSCAPE STANDARDS &
SPECIFICATIONS**

SHEET NO: COCH-LS 102

DRAWN BY: CB

DATE: 2014 Jan

SCALE: N.T.S.

All dimensions are in imperial
(inches) unless otherwise specified.

Source: City of Calgary Standard
Specifications for Landscape
Construction, 2013.

LEGEND & REFERENCES:

Cutting List

Side Boards	18 pcs.	2x6x96	
End Boards	18 pcs.	2x6x45	
Bottom Members	2 pcs.	4x4x93	
	2 pcs.	4x4x38	
Vertical Members	14 pcs.	4x4x43-1/8	
Top Members			
	2 pcs.	4x4x93	Mitered
	2 pcs.	4x4x45	Mitered
Bottom Braces			
	4 pcs	4x4x45	Notched
Material: Wood - Pressure Treated Pine			

Main Angular Frame

General Arrangement

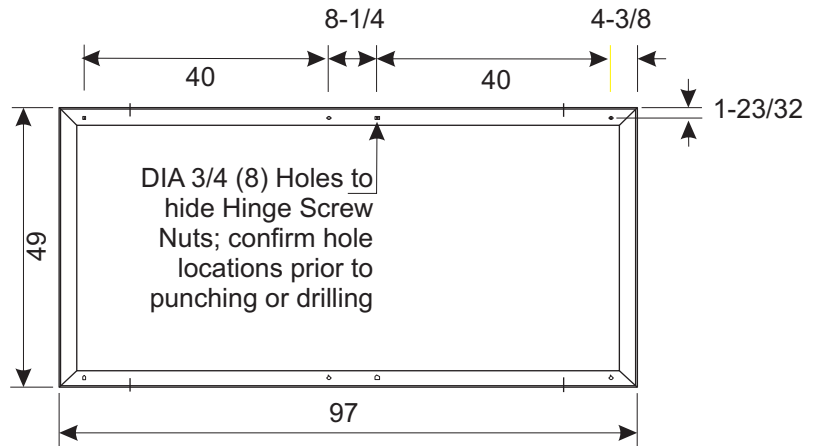
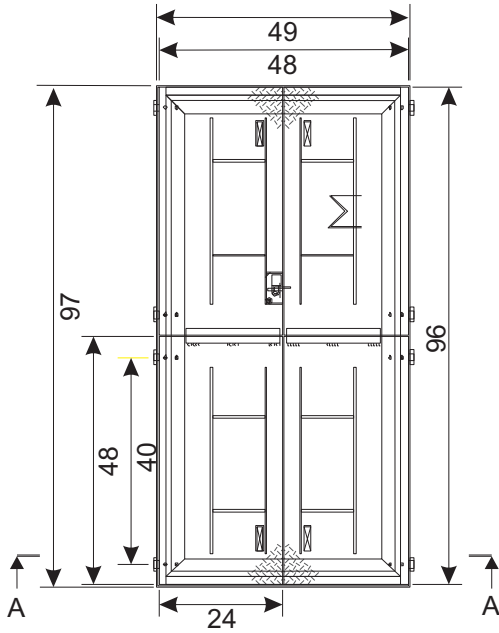

Weld (4) O-Rings to sides of Frame so it can be lifted (Part No. 09111 Erickson)

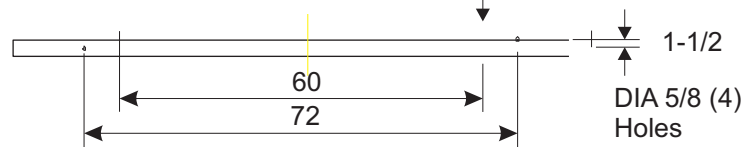

304 SS Angle Frame 3 x 3 x 1/4

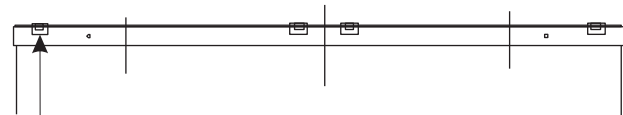

Short end of each hinge to be welded to the angular frame; SS Strap Hinge HTD-120 Faucher



Section A-A

For Main Wooden Box c/2w Crossbeam see Sheet 104

CITY OF CHESTERMERE

Development & Infrastructure
Services
Parks Department



PR.0020.11
January, 2015

SHEET TITLE:

Frame with Aluminum Lid -
Double Check Valve Assembly
- 100 mm -

**LANDSCAPE STANDARDS &
SPECIFICATIONS**

SHEET NO: COCH-LS 103

DRAWN BY: CB

DATE: 2014 Jan

SCALE: N.T.S.

All dimensions are in imperial
(inches) unless otherwise specified.

Source: City of Calgary Standard
Specifications for Landscape
Construction, 2013.

LEGEND & REFERENCES:

Crossbeam Detail

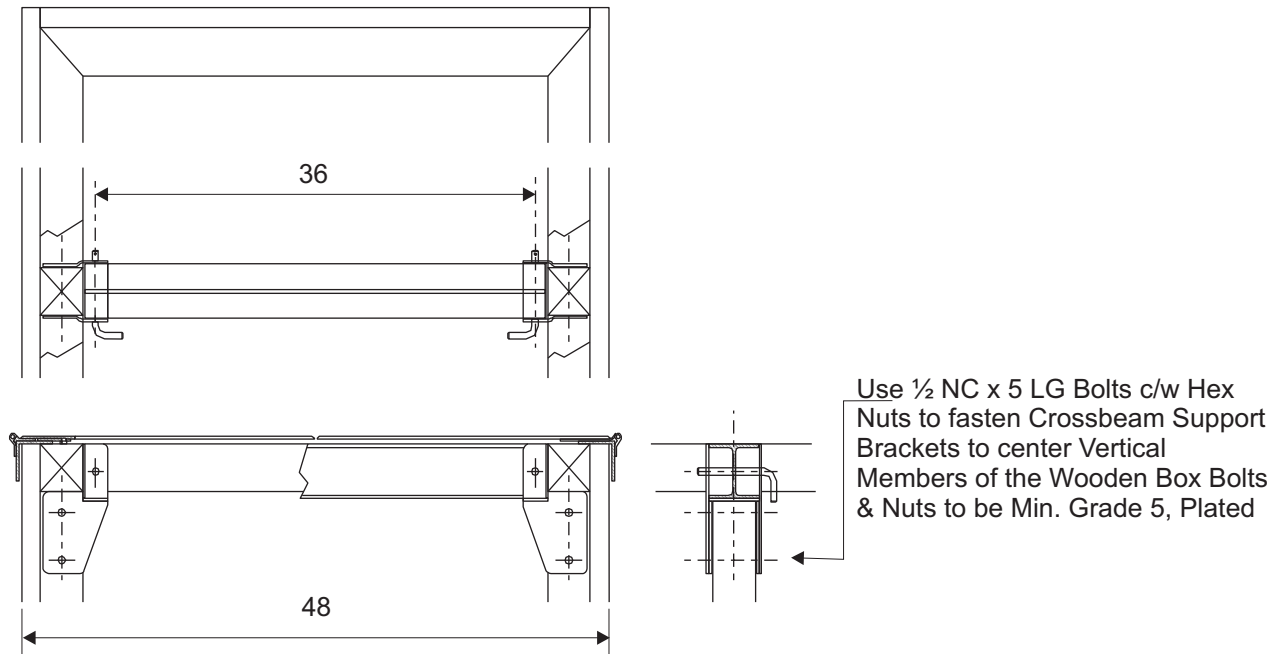

Crossbeam

6061-T6 Aluminum H-Beam 4 x 4 x 1/4

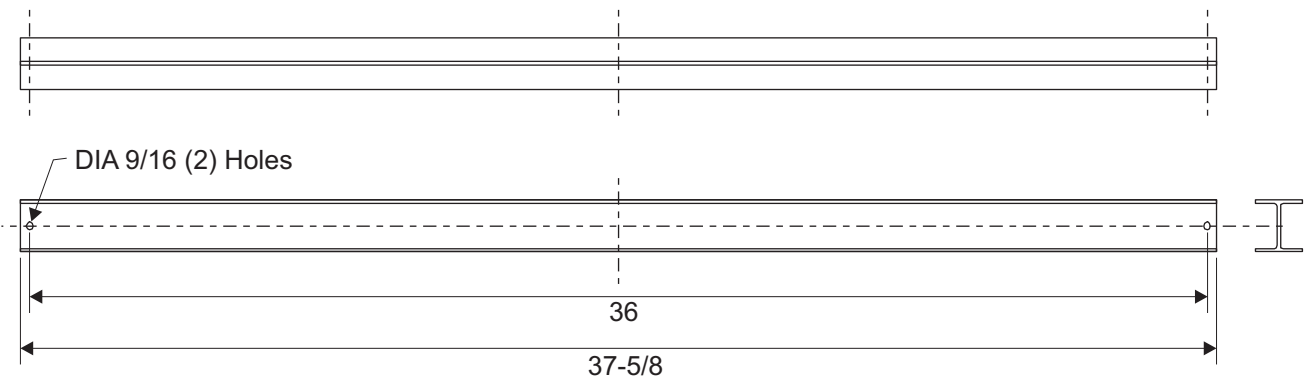

CITY OF CHESTERMERE

Development & Infrastructure
Services
Parks Department



PR.0020.11
January, 2015

SHEET TITLE:

Valve Box Crossbeam Support -
Double Check Valve Assembly
- 100 mm -

**LANDSCAPE STANDARDS &
SPECIFICATIONS**

SHEET NO: COCH-LS 104

DRAWN BY: CB

DATE: 2014 Jan

SCALE: N.T.S.

All dimensions are in imperial
(inches) unless otherwise specified.

Source: City of Calgary Standard
Specifications for Landscape
Construction, 2013.

LEGEND & REFERENCES:

Crossbeam Supports

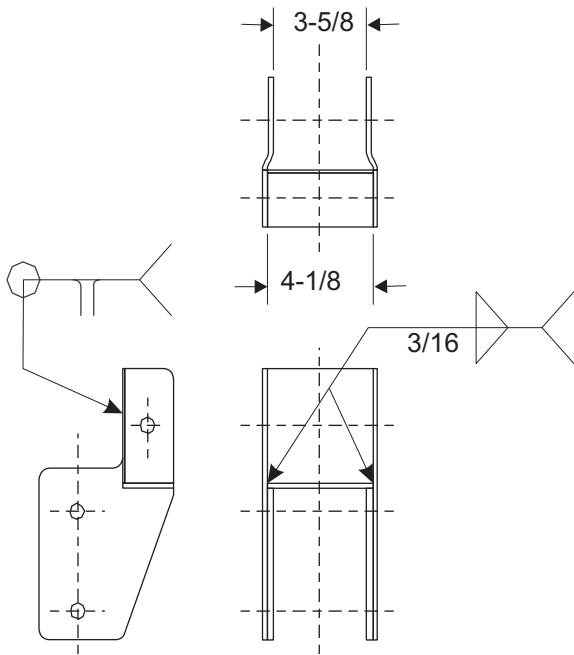

Side Plates: Left & Right

304SS Plate 3/16

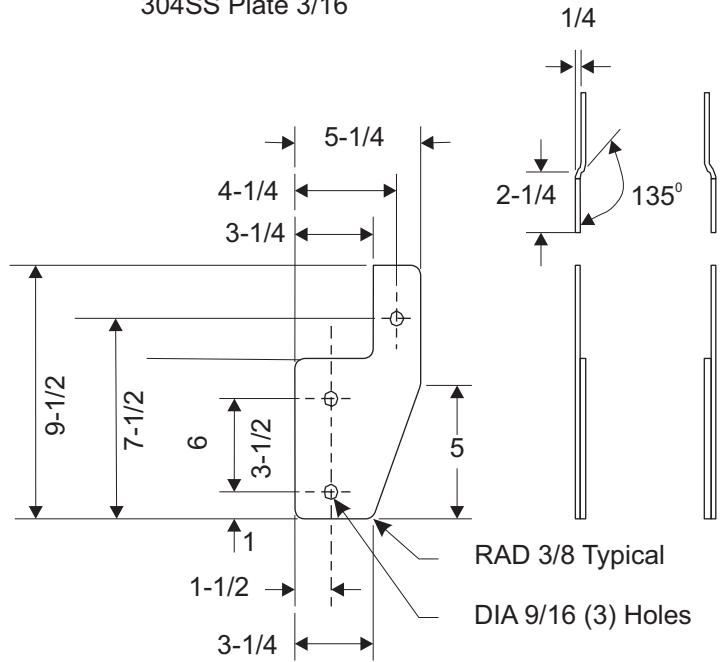

Pin

304SS Round Bar Dia 1/2

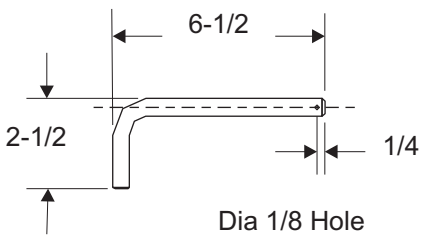

Shelf

304SS Plate 3/16

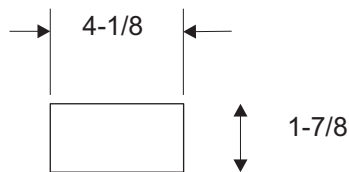

Back Plate

304SS Sheet 12 GA

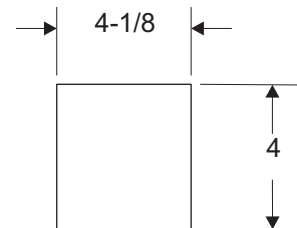

CITY OF CHESTERMERE
Development & Infrastructure
Services
Parks Department



PR.0020.11
January, 2015

SHEET TITLE:
Valve Box Crossbeam Support,
Double Check Valve Assembly
- 100 mm -

LANDSCAPE STANDARDS & SPECIFICATIONS

SHEET NO: COCH-LS 105
DRAWN BY: CB
DATE: 2014 Jan
SCALE: N.T.S.

All dimensions are in imperial (inches) unless otherwise specified.

Source: City of Calgary Standard Specifications for Landscape Construction, 2013.

LEGEND & REFERENCES:

Attach hinges to cover plates with 1/4 NC x 3/4 LG 304SS flat head screws c/w SS hex nuts; countersink holes in cover plates

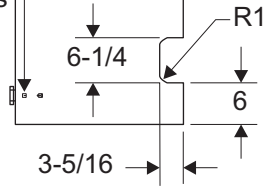

Mark location of meter on top cover; weld-on "m" in the center of cover

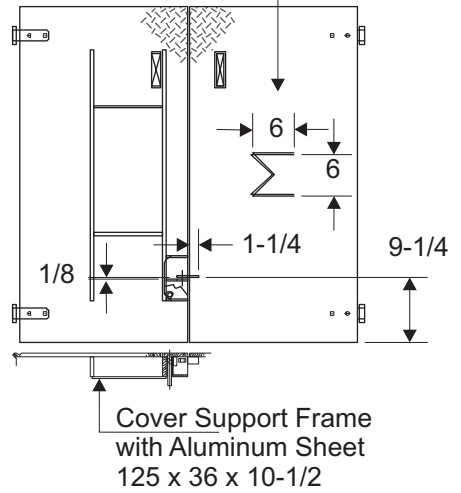

Welding Pattern Bottom View of Cover

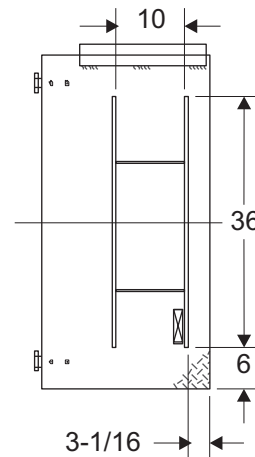
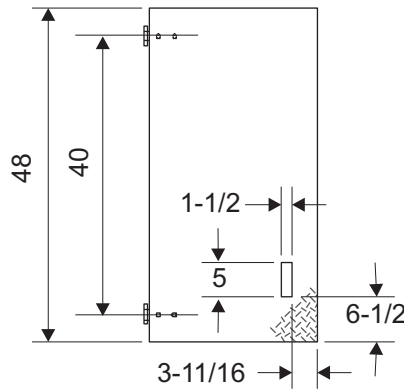
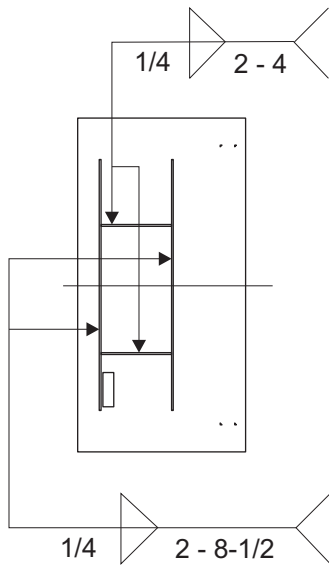

CITY OF CHESTERMERE

Development & Infrastructure Services
Parks Department



PR.0020.11
January, 2015

SHEET TITLE:

Double Check Valve Box
Aluminum Lid
- 100 mm -

LANDSCAPE STANDARDS & SPECIFICATIONS

SHEET NO: COCH-LS 107

DRAWN BY: CB

DATE: 2014 Jan

SCALE: N.T.S.

All dimensions are in imperial (inches) unless otherwise specified.

Source: City of Calgary Standard Specifications for Landscape Construction, 2013.

LEGEND & REFERENCES:

1. Brake edges of each cover plate 1/4 aluminum checker plate.

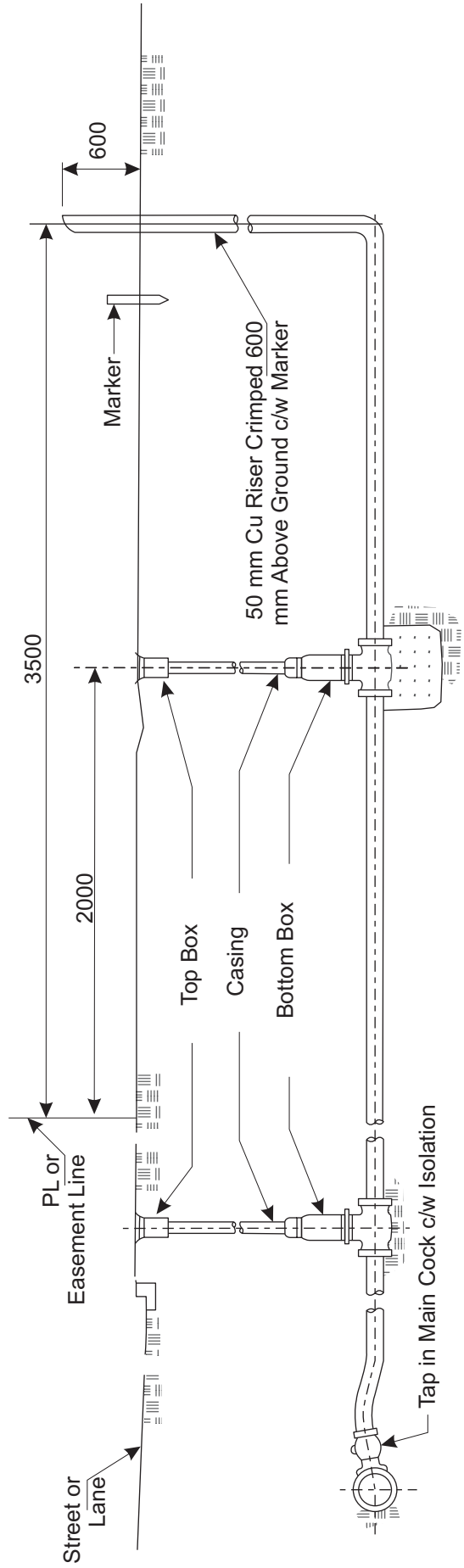

Cross-Section

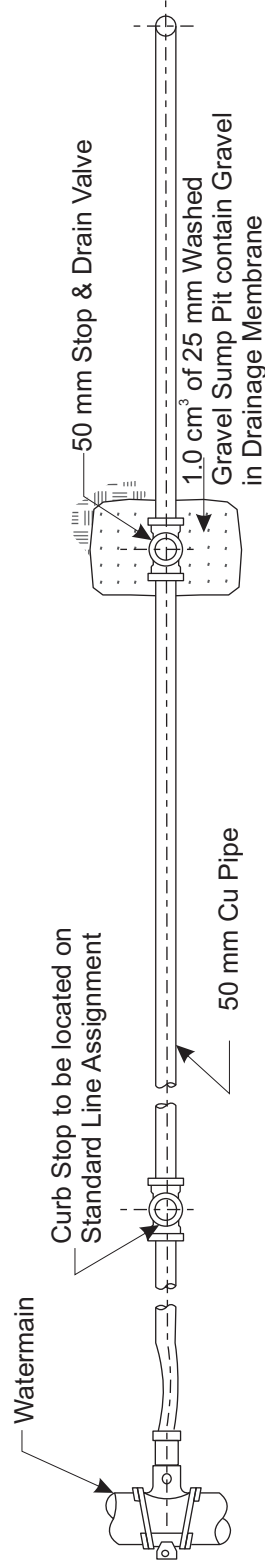

Plan

LEGEND & REFERENCES:

SHEET NO:	COCH-LS 108	Units are in millimetres unless otherwise noted.
DRAWN BY:	CB	
DATE:	2014, Jan	
SCALE:	N.T.S.	
Source: City of Calgary Standard Specifications for Landscape Construction, 2013.		

SHEET TITLE:	Typical Parks Water Service - 50 mm -
PROJECT TITLE:	LANDSCAPE STANDARDS & SPECIFICATIONS

CITY OF CHESTERMERE
Development & Infrastructure Services
Parks Department



PR.0020.11
January, 2015

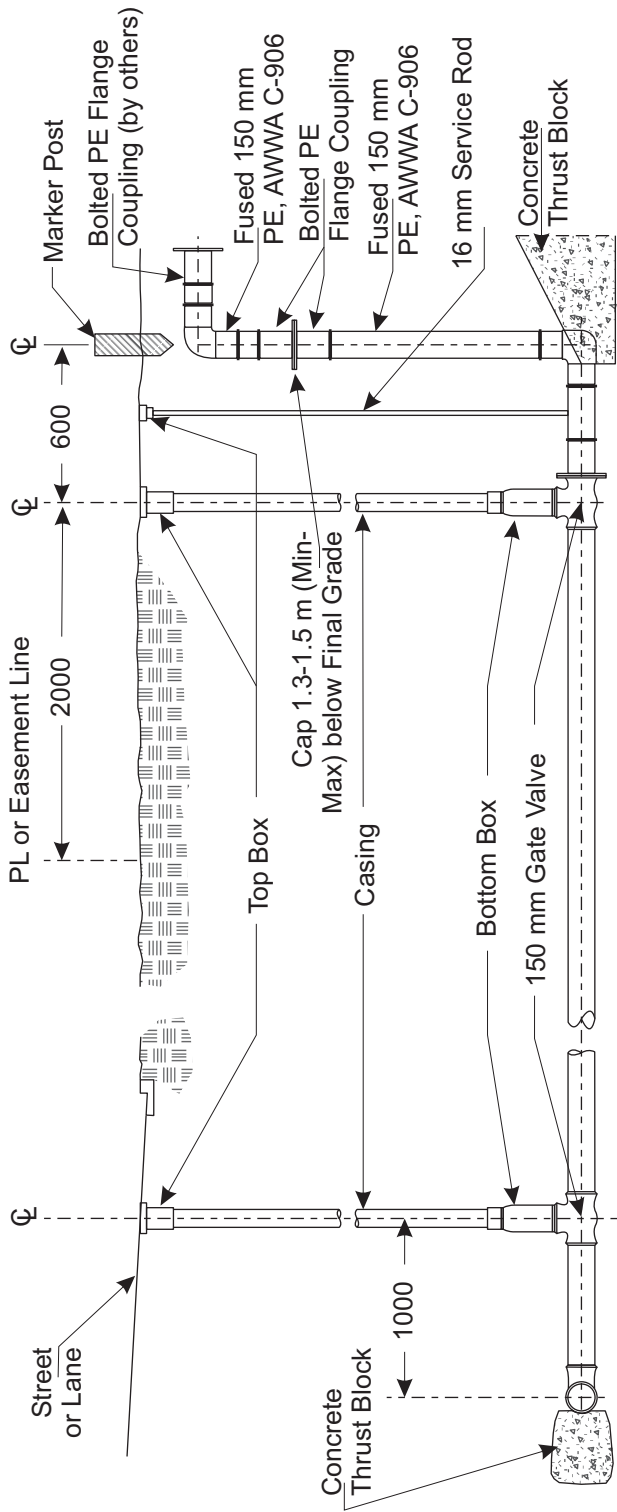

Cross-Section

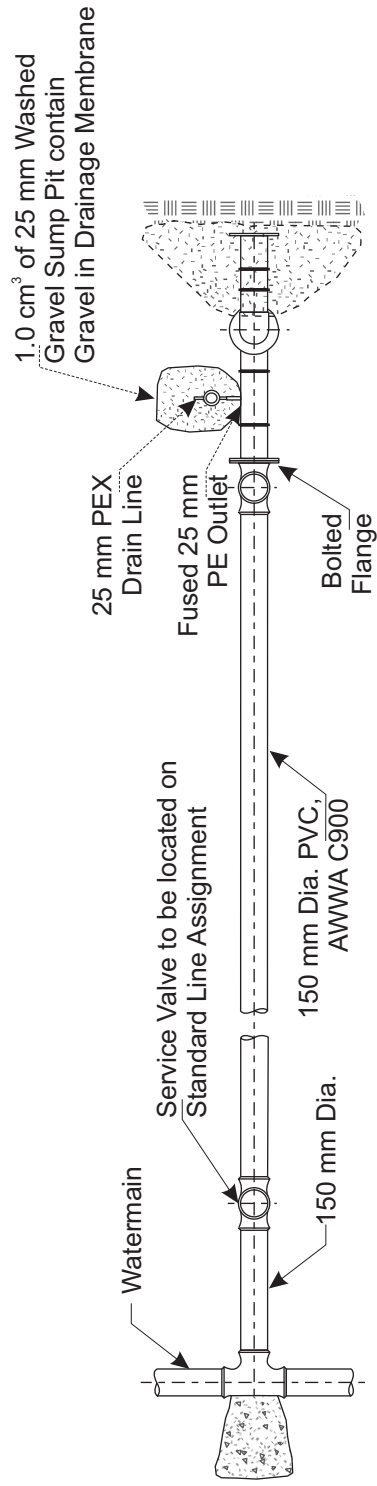

Plan

LEGEND & REFERENCES:

SHEET NO:	COCH-LS 109	Units are in millimetres unless otherwise noted.
DRAWN BY:	CB	
DATE:	2014/Jan	
SCALE:	N.T.S.	

Source: City of Calgary Standard Specifications for Landscape Construction, 2013.

SHEET TITLE:	Typical Parks Water Service - 150 mm -
PROJECT TITLE:	LANDSCAPE STANDARDS & SPECIFICATIONS

CITY OF CHESTERMERE
Development & Infrastructure Services
Parks Department

PR.0020.11
January, 2015



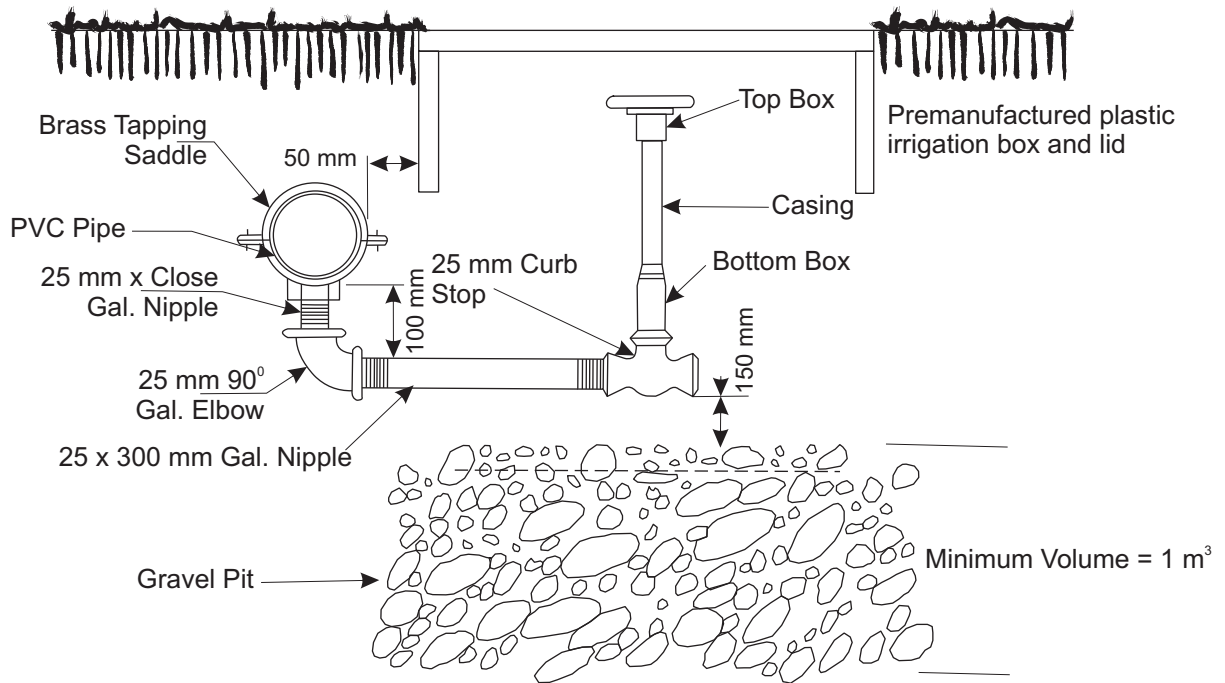

Elevation

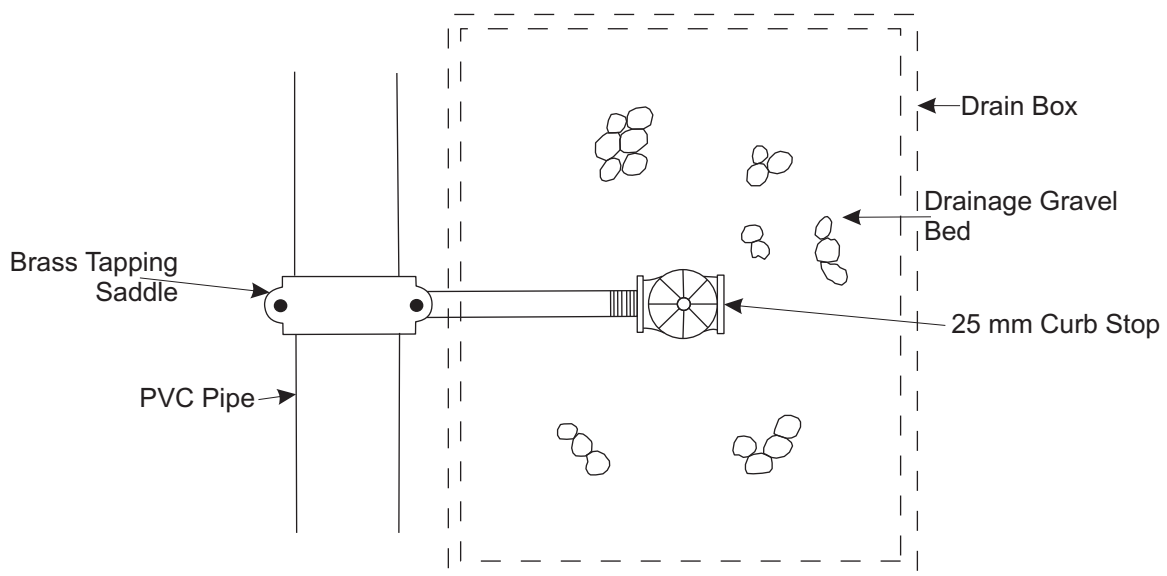

Plan

CITY OF CHESTERMERE
 Development & Infrastructure
 Services
 Parks Department



PR.0020.11
 January, 2015

SHEET TITLE:

Curb Stop Assembly
 - 25 mm -

LANDSCAPE STANDARDS & SPECIFICATIONS

SHEET NO:	COCH-LS 110
DRAWN BY:	CB
DATE:	2014 Jan
SCALE:	N.T.S.

All dimensions are in millimetres unless otherwise specified.

Source: City of Calgary Standard Specifications for Landscape Construction, 2013.

LEGEND & REFERENCES:

1. Locate Drain Pits at lowest relative grade to ensure positive gravity drainage.
2. Size of Drainage Pit shall vary with pit conditions and pipe size.
3. For medium density polyethylene pipe installation, use double clamped insert fittings in lieu of brass tapping saddle.
4. Box Measurements: (all outside measurements)

Bottom	391 mm x 536 mm
Top	298 mm x 431 mm
Height	304 mm

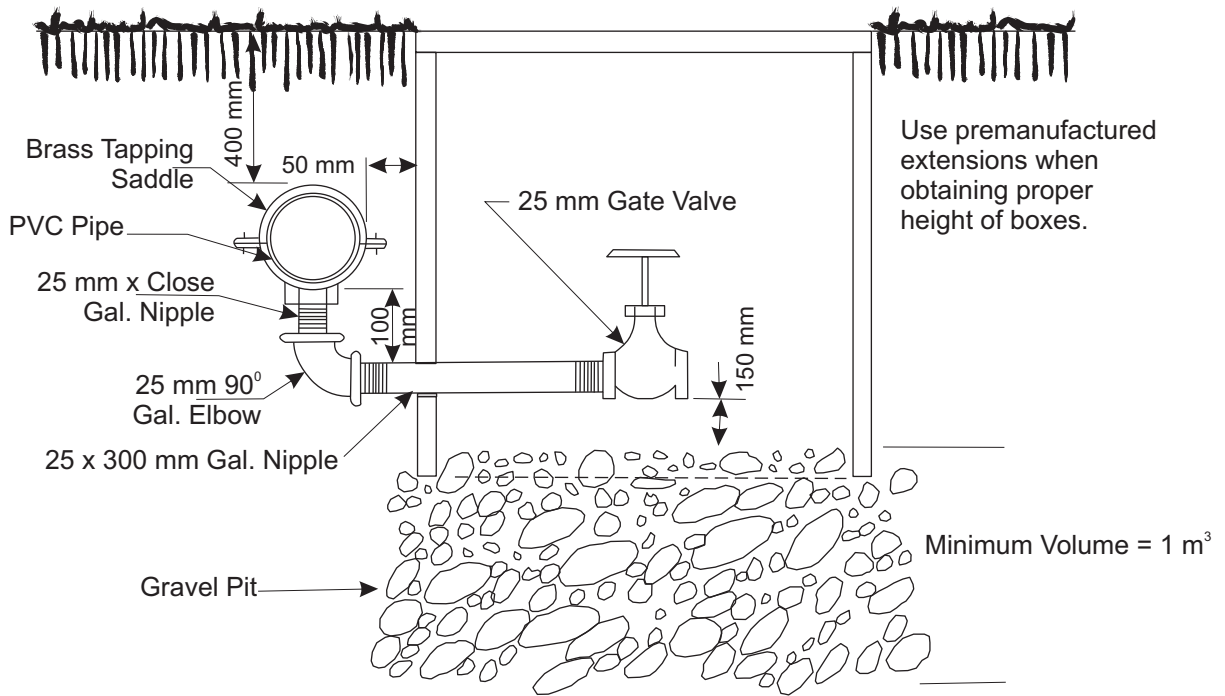

Elevation

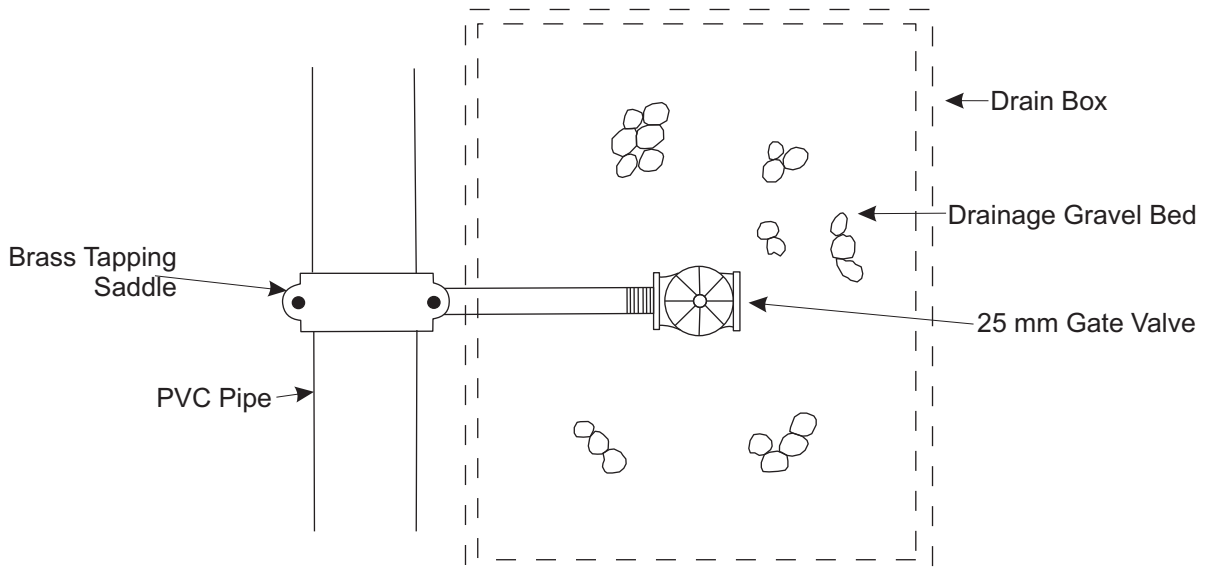

Plan

CITY OF CHESTERMERE
 Development & Infrastructure
 Services
 Parks Department



PR.0020.11
 January, 2015

SHEET TITLE:

Drain Pit
 - PVC Pipe -

LANDSCAPE STANDARDS & SPECIFICATIONS

SHEET NO:	COCH-LS 111
DRAWN BY:	CB
DATE:	2014 Jan
SCALE:	N.T.S.

All dimensions are in millimetres unless otherwise specified.

Source: *City of Calgary Standard Specifications for Landscape Construction, 2013.*

LEGEND & REFERENCES:

1. Locate Drain Pits at lowest relative grade to ensure positive gravity drainage.
2. Size of Drainage Pit shall vary with pit conditions and pipe size.
3. For medium density polyethylene pipe installation, use double clamped insert fittings in lieu of brass tapping saddle.
4. Box Measurements: (all outside measurements)

Bottom	391 mm x 536 mm
Top	298 mm x 431 mm
Height	304 mm